

---

## To Users

——Notices of Onsite Installation and Operation

Respectful User:

Thanks for your Option of E Series Frequency inverter manufactured by Delixi (Hangzhou) Inverter Co., Ltd. In order that you can better use the product, please pay attention to the following:

1. After frequency inverter is installed and commissioned, fasten the components, especially connecting bolt of the line, which shall cause fire accident due to heat at the connection if not fastened.
2. Design of installation on the site should be reasonable to maintain excellent ventilation.
3. In and out lines of the frequency inverter should not be connected reversely. Otherwise, it shall lead to frequency inverter explosion.
4. Starting and stopping the motor directly by power-on and power-off the main circuit of the frequency inverter shall cause frequent jumping faults to the frequency inverter.
5. When selecting frequency inverter type, configure the frequency inverter as per actual load power (load working current). When there is heavy load, type selection can be magnified by 1 to 2 shifts. Smaller type shall cause overcurrent or overload jumping faults to the frequency inverter.
6. Protection level of the frequency inverter is IP20, that is, it can prevent a foreign matter with a diameter of 12.5mm or greater from completely entering, without waterproof function.
7. Frequency inverter if stored for more than half a year should be powered with a voltage regulator to increase voltage gradually. Otherwise, there is danger of electric shock and explosion.
8. If line connecting the frequency inverter to the motor exceeds 50m, it is required to add AC output inductor. Otherwise, the frequency inverter and the motor are in danger of damage

In order that you can use the product safely for a long time, you need to carefully inspect the product, regularly power off it to clean and maintain. For any trouble in process of inspection, please notify us by phone or mail. Our service hotline is 0571-85243785. We shall send professional to your site as per your trouble to assist you in solving the trouble and ensure the product is operated safely and reliably.

## Foreword

Chapter 1 Safety Operation and Notices.....	1
1.1 Examination and Acceptance.....	1
1.2 Precautions for safe operation:.....	2
Chapter 2 Product Information .....	4
2.1 Nameplate data and naming rule.....	4
2.2 Technical Specifications .....	5
2.3 Product List.....	9
2.4 Appearance and installation size.....	17
2.5 Routine maintenance.....	25
Chapter 3 Installation and Connection of Frequency inverter .....	27
3.1 Option of the Site and Space for Installation .....	27
3.2 Wiring of the Peripherals and Optional parts.....	29
3.3 Wiring of the main circuit.....	30
3.3.1 Wiring diagram for the main circuit and precautions .....	30
3.3.2 Precautions for wiring the input side of the main circuit .....	32
3.3.3 Precautions for wiring the output side of the main circuit .....	33
3.3.4 Wiring and Supporting Peripherals for Main Circuits .....	34
3.4 Connection of control circuit .....	37
3.4.1 Arrangement and connection of controlling circuit terminals .....	37
3.4.2 Function of control circuit terminal .....	40
3.4.3 Wiring Instruction for Control Circuit .....	41
3.5 Grounding.....	44
Chapter 4 Keyboard Operation and Running .....	45
4.1 Option of operating mode .....	45
4.2 Test run and inspection .....	45
4.2.1 Precautions and inspection before test run.....	45
4.2.2 Test run .....	45
4.2.3 Operating inspection .....	45
4.3 Operating method of keyboard. ....	46
4.3.1 Keys on keyboard and their functions .....	46
4.3.2 Data Monitoring Mode .....	51
4.3.3 Use of Multi- Function Key JOG.....	51
4.3.4 Parameter check and set methods (using digital keyboard).....	52
4.4 Function Code Display Mode .....	53
Chapter 5 Tables of Function Parameters .....	54
5.1 P0 Group - Basic Function.....	55
5.2 Group P1 - Motor Control Parameter .....	59
5.3 Group P2 - Input/Output Terminal Function.....	61
5.4 Group P3 - Programmable Function .....	66
5.5 Group P4 - PID Control And Communication Control.....	72
5.6 Group P5 - Keyboard Display.....	74
5.7 Group P6 - Fault Display and Protection .....	77
5.8 Group P7 - User Function Customization.....	81
5.9 Group P8 - Manufacturer Function .....	82
5.10 Group P9 - Monitoring Parameter .....	83
Chapter 6. Description of Parameters .....	84
6.1 Group 0 - Basic Function.....	84
6.2 Group P1 - Motor Control Parameter .....	97
6.3 Group P2 - Input/Output Terminal Function.....	106
6.4 Group P3 - Programmable Function .....	125
6.5 GROUP P4 PID CONTROL AND COMMUNICATION CONTROL .....	134
6.6 Group P5 Keyboard Display .....	140
6.7 Fault Display and Protection Control Group P6 .....	146
6.8 Group P7 User Function Customization .....	152
6.9 Group P8 Manufacturer Function .....	153
6.10 Group P9 Monitoring Parameter.....	155
Chapter 7 Common Function and Application Case.....	157

## Foreword

7.1 Common Function .....	157
7.1.1 Start and Stop Control.....	157
7.1.2 Start and Stop Mode.....	159
7.1.3 Acceleration and Deceleration Mode.....	161
7.1.4 Jogging Function .....	161
7.1.5 Running Frequency Control.....	162
7.1.6 Multi-speed Function .....	163
7.1.7 Simple PLC.....	163
7.1.8 Timing Function.....	164
7.1.9 Fixed-length Function.....	165
7.1.10 Counting Function .....	166
7.1.11 Distance Control Function .....	167
7.1.12 Simple Internal Relay Programmable Function.....	168
7.1.13 Internal Timer Function .....	171
7.1.14 Internal Operation Module Function.....	172
7.1.15 PID FUNCTION.....	175
7.1.16 Wobblating Function.....	175
7.1.17 Analog Input/Output Use.....	177
7.1.18 Digital Input/Output Use.....	178
7.1.19 Communication of Upper Computer.....	179
7.1.20 Parameter Identification.....	180
7.2 Application Cases .....	182
7.2.1 Switching function of dual-pump .....	182
7.2.2 PID control for Water Supply at Permanent Pressure .....	183
7.2.3 Ball mill .....	187
7.2.4 Injection Molding Machine .....	190
7.2.5 Local/ Remote Control.....	193
Chapter 8 E Series Frequency Inverter RS-485 Communication .....	194
9.1 Frequency inverter Fault and Exclusion Measure.....	202
9.2 Motor Fault and Exclusion Measure.....	207
Appendix 1 Regular Maintenance and Inspection Methods .....	208
A2.1 Alternative Current Reactor (ACL) .....	210
A2.2 DC reactor.....	211
A2.3 Radio noise filter.....	211
A2.4 Remote Operation Keyboard .....	211
A2.5 Energy Consumption Brake Unit and Brake Resistance.....	212
Appendix 3 E180 I/O Expansion Card .....	216
Appendix 4 E180 Encoder Expansion Card .....	218
Appendix 5 Expansion Card of RS485 Communication .....	220
Appendix 6 Expansion Card of E180 Injection Molding Machine .....	221
Appendix 7 E180-DP Expansion Card .....	222
Appendix 8 E180-WSP Expansion Card .....	225

## Foreword

Thank you for choosing E Series Frequency inverter manufactured by Delixi (Hangzhou) Inverter Co., Ltd. It includes CDI-E100 Series, E102 Series and CDI-E180 Series.

Before using it, please read this manual carefully so as to guarantee correct operation. Erroneous operation might result in malfunction, faults or shortened life span of the equipment, or even personal injury. Therefore, users are advised to read carefully this manual and abide by it during operation. The manual is a standard attached document. Please keep it for maintenance and repair in the future.

Aside from operation instructions, this manual also presents some wiring diagrams for your reference. If you have any difficulty or special demands for using the frequency inverter, please contact our offices or distributors. You may also contact the customer service centre of our head office for our quality service. The manual noted that its content might change without further notice.

Please confirm following content during unpackaging:

1. If the product is damaged during process of transportation, if parts are damaged and dropped, or if main body is bruised.
2. If rated value marked on nameplate is consistent with your order requirement, or if there are ordered Unit, acceptance certificate, operation manual and guarantee shed in package.

The Company strictly complies with quality system during production and packaging, for any inspection miss, please contact our Company or supplier for settlement.



### **Warning**

People should not reprint, transmit, and use the manual or content relating to it without written permission of the Company, who will assume legal responsibility for damage caused in violation of the item.

## Chapter 1 Safety Operation and Notices

Please read the manual carefully before install, operate, maintain or check E Series Frequency inverter.

To protect yourself, the equipment, and the property from any possible harm, please do read this chapter before using our E Series Frequency inverters. Precautions relevant to operation safety are categorized as “Warning” and “attention”.



Warning

: Potentially dangerous condition, which maybe cause severe body injuries or dead if relevant requirement is ignored.



Attention

: Potentially dangerous condition, which maybe cause middle, light injuries or device damage if relevant requirement is ignored, it also applies to unsafe operation.

### 1.1 Examination and Acceptance

Items to be examined are as follows:

Items	Note
1. Does the model conform to your order?	Check the Model indicated on the nameplate on one side of the frequency inverter.
2. Is there any damage to the components?	Survey the external appearance of the frequency inverter and make sure that no damage has occurred during transportation
3. Are the components properly fastened?	Remove the front cover and examine all visible components with appropriate tools.
4. Do you have the user's manual, the quality certificate and the warranty claims form?	Check for the user's manual, the quality certificate and the warranty claims form

If any of the above items is problematic, please contact us or our distributors.

1.2 Precautions for safe operation:

 Warning	1. Installation and maintenance should be performed by professional only.
	2. Verify that rated voltage of the frequency inverter should conform with voltage level of AC power supply. Otherwise it shall cause hurt to human body or fire accident.
	3. Do not make supply power of AC loop connect with outputting terminal U, V and W. The connection will damage converser, thus guarantee card should be nonserviceable.
	4. Only connect it to input power supply after the panel is well installed. Do not remove the external lid when it is powered; otherwise it may cause electric shock.
	5. Forbid touching high voltage terminal inside the frequency inverter when it is powered on; otherwise, there is danger of electric shock.
	6. Because there is an amount of capacitance stored electric energy inside the frequency inverter, maintenance should be implemented at least 10 minutes after the power is off. At this time, charging indicator should be off thoroughly or positive or negative Bus line voltage is confirmed to be below 36V; otherwise there is danger of electric shock.
	7. Do not turn on or off line and connector when the circuit is powered on; otherwise it can cause hurt to human body.
	8. Electric elements can be easily damaged by static electricity. Do not touch electric elements.
	9. This frequency inverter should not undergo voltage withstand test, which might result in damages to the semiconductor devices in it.
	10. Before switching on the power supply, please put the cover board in position. Otherwise, electric shock or explosion might occur.
	11. Never confuse the input terminals. Otherwise, explosion or damage to the property might occur.
	12. For frequency inverter of which storage period exceeds half year, please increase the input voltage gradually by using regulator, to prevent from electric shock and explosion.
	13. Do not operate the frequency inverter with wet hand; otherwise, there is danger of electric shock.
	14. All parts should be replaced by professional only. It is strictly prohibitive to remain stub or metal object in machine, to prevent from fire.
	15. After replaced control board, please perform relevant parameter setting before operation to prevent from damage of materials.

  
**ESD**  
 Electro Static  
 Discharge  
 (ESD)

 Attention	1. If the motor is used for the first time or has been in leisure for a long time, remember to check its insulation first. It is advisable to use a 500V megger. Make sure the insulation resistance should not be less than 5 MΩ..
	2. If you need to operate the frequency inverter at frequencies beyond 50Hz, please consider the support capability of the mechanical devices.
	3. The output at certain frequencies might encounter the resonance points of load devices. This can be avoided by resetting the jump frequency parameter of the frequency inverter.
	4. Do not use three-phase frequency inverters as two-phase ones. Otherwise, fault or damage might occur.
	5. In regions at an altitude of more than 1000 meters, the heat dissipation capability of the frequency inverter might be compromised because of the thin air. Therefore, de-rated operation will be necessary. In such cases, please contact us for technical advice.
	6. The standard matched motor is a four-pole squirrel-cage asynchronous machine. In case of discrepancy, please choose appropriate frequency inverters in accordance with the rated current of the motor.
	7. Do not start or stop the frequency inverter with contactors. Otherwise, damage might occur to the equipment.
	8. Do not modify factory set value of frequency inverter without authorization, or damage might be caused.

## Chapter 2 Product Information

### 2.1 Nameplate data and naming rule

Nameplate data: for example CDI-E180G011/P015T4BL:

**Model:** CDI-E180G011/P015T4BL

**Input:** AC 3PH 380 ± 15% 50/60Hz

**Output:** AC 3PH 0~380V 0~3200Hz 25/32A

Hardware Version: 1.1.00    Software Version: 1.12



E180G011/P015T4BL13F0001

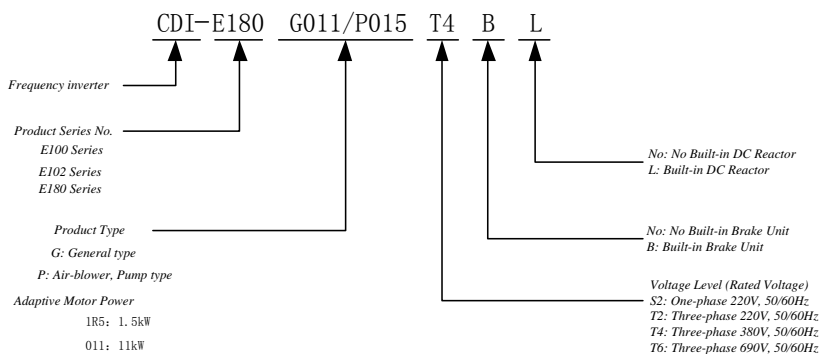

## 2.2 Technical Specifications

Item		Specification	
Control	Control mode	V/F Control Open-loop Vector Control (SVC) Closed-loop Vector Control (VC)( Invalid CDI-E100 Series)	
	Frequency Resolution	Digital: 0.02% Analog: 0.1%	
	V/F curve	Linear, square root, random V/F	
	Overload Capability	G Model: 60s for 150% of the rated current; 3s for 180% of the rated current; P Model: 60s for 120% of the rated current; 3s for 150% of the rated current;	
	Start Torque	G Model: 0.5Hz/150% (SVC); 0Hz/180% (VC) P Model: 0.5Hz/100%	
	Speed Regulation Range	1:100 (SVC)                      1:1000 (VC)	
	Stable Speed Accuracy	±0.5% (SVC)                      ±0.02% (VC)	
	Torque Control Accuracy	±5% (VC)	
	Torque Compensation	Manual torque compensation (0.1%~30.0%), automatic torque compensation	
Configuration	Control power supply P24V	E100	Max. Output Current 300mA with current-limiting protection
		E102	Max. Output Current 300mA without current-limiting protection
		E180	Max. Output Current 300mA with current-limiting protection
	Input Terminal	E100	6-way Digital Input Terminal (DI1~DI6), in which DI6 can access to high-speed Impulse Input (both built-in and external power supply are available). 2-way Analog Input Terminal (VF1, VF2), which can be used as voltage (0V~10V) or current (0/4mA~20mA) input. It can be used as Digital Input Terminal through reference.
		E102	5-way Digital Input Terminal (DI1~DI6), in which DI6 can access to high-speed Impulse Input (only internal power supply is available) 2-way Analog Input Terminal (VF1, VF2), which can be used as voltage (0V~10V) or current (0/4mA~20mA) input. It can be used as Digital Input Terminal through reference.
		E180	6-way Digital Input Terminal (DI1~DI6),in which DI6 can access to high-speed Impulse Input. Through external I/O expansion card, it can be expanded to 4-way(DI7~DI10). 2-way Analog Input Terminal (VF1, VF2), which can be used as voltage (0V~10V) or current (0/4mA~20mA) input. It can be used as Digital Input Terminal through setting <b>NOTE: Both internal power supply and external power supply can be used for DI1~DI6, only internal power supply can be used for DI7~DI10.</b>

Item		Specification
Configuration	Output Terminal	E100 2-way Analog Input Terminal (FM1, FM2), which can not only be used as output voltage (0V~10V),but output current (0mA~20mA) 1-way open collector output (YO), DC 48V 50Ma below 1-way Impulse output (FMP), Frequency Range between 0.01kHz~100.00kHz 2-way Relay Output (T1, T2), DC 30V/3A below and AC 250V/3A below <b>Note: YO and FMP are common YO/FMP terminal, but only one can be used at the same time.</b>
		E102 1-way Analog Input Terminal FM1, which can not only be used as output voltage (0V~10V),but output current (0mA~20mA). 1-way Relay Output T1, DC 30V/3A below and AC 250V/3A below
		E180 2-way Analog Input Terminal (FM1, FM2), which can not only be used as output voltage (0V~10V),but output current (0mA~20mA) 1-way open collector output (YO), DC 48V 50Ma below. Additional 2-way open collector output (YO1, YO2) can be added through external IO expansion card. 1-way Impulse output (FMP), Frequency Range between 0.01kHz~100.00kHz 2-way Relay Output (T1, T2), DC 30V/3A below w and AC 250V/3A below <b>Note: YO and FMP are common YO/FMP terminal, but only one can be used at the same time.</b>
Running	Operating mode	Keyboard, terminal, RS485 communication
	Frequency Source	14 kinds of main frequency sources and 14 kinds of auxiliary sources. Adopt various combination modes to switch. Diversification to Each Frequency Source Input Mode: keyboard potentiometer, external analog, digital reference, impulse reference, Multiplex Directive, simple PLC, communication, arithmetic results, etc.
	Torque Source	14 kinds of Torque Sources, including digital reference, external analog, impulse reference, Multiplex Directive, communication, arithmetic results, etc.
	Acceleration and Deceleration Time	Four groups of straight lines (select the terminal to switch through acceleration and deceleration time), S Curve 1 and S Curve 2
	Emergency stop	Interrupt output of frequency inverter.
	Multiplex Speed	16 speed is allowable to set at most and use various combination of multiplex directive terminal to switch
	Simple PLC Function	Continuously run 16-phase speed and independently set acceleration and deceleration time and running time
	Jogging Control	Independently set Jogging frequency and jogging acceleration and deceleration time, additionally, set the unit under running state and confirm whether the jogging is preferential
	Rotating Speed Tracking	Frequency inverter starts operation by tracking the load speed
Fixed-length and Fixed-distance Control	Realize fixed-length and fixed-distance control function through Impulse Input	

Item	Specification	
Running	Control mode	Realize counting function through Impulse Input
	Wobblulating Function	Apply for textile winding equipment
	Built-in PID	Realize process control closed loop system
	AVR Function	When the grid voltage fluctuates, ensure constant output
	DC Braking	Realize fast and stable shut-down
	Slip Compensation	Compensate the speed deviation caused by the increase of load
	Hopping Frequency	Prevent resonance from occurring with load
	Sagged Function	Balance the load of multiple motors with same load
	Timing Control	Be able to realize automatic shutdown of the frequency inverter when reaching given time
	Built-in Virtual Delay Relay	Realize simple logic Programming to multi-functional output terminal function and digital input terminal signal, the logic results can not only be equivalent to digital input terminal function, but can be output through multi-functional terminal output
	Built-in Timer	Build in 2 timers and acquire the timing input signal to realize timing signal output. Use alone or in combination
	Operation Module Built-in Operation Module	One built-in 4-way Operation Module to realize simple addition, subtraction, multiplication and division, size judgment and integral operation
Communication	E100	The control panel is directly equipped with RS485 Communication Interface and supports Standard MODBUS Protocol
	E102	The control panel is not equipped with built-in RS485 Communication Interface, so external communication expansion card is required. It supports Standard MODBUS Protocol (External Connection of E102-485 Expansion Card)
	E180	The control panel is not equipped with built-in RS485 Communication Interface, so external communication expansion card is required. It supports Standard MODBUS Protocol (External Connection of E180-485 Expansion Card)
Encoder	E100	Be able to connect the encoder through Terminal DI5 & DI6 on control panel, such an encoder connection method can realize simple closed-loop control through PID Control and used for occasions without high requirements to control accuracy.
	E102	Only connect to 1-way pulse signal of encoder (DI6)
	E180	The control panel is not equipped with encoder interface, so external encoder expansion card is required. It supports ABZ Incremental Encoder, UVW Incremental Encoder and Rotary Transformer. This encoder connection method can realize high-performance closed-loop vector control and be used for occasions with high requirements to control accuracy.
Type of Motor	E100	Only be equipped with asynchronous motor
	E102	Only be equipped with asynchronous motor
	E180	Not only be equipped with asynchronous motor, but synchronous motor

Item		Specification
Display	Running information	Given frequency, output current, output voltage, Bus line voltage, input signal, feedback value, module temperature, output frequency, motor synchronous speed, etc. Through >> Key, display 32 loops at most
	Error information	Save the historical information of 3 faults under running state of fault protection. Every piece of fault information includes frequency, current, Bus line voltage and input/output terminal status when fault happens.
Protection	Frequency inverter protection	Overcurrent, overvoltage, module fault protection, undervoltage, overload, external fault protection, EEPROM fault protection, ground protection, default phase, etc.
	Frequency inverter alarm	Locked protection, overload alarm
	Instantaneous power-off	Lower than 15 ms: Continuous operation Bigger than 15 ms: Automatic restart is allowable
Environment	Ambient temperature	-10°C~40°C
	Storage temperature	-20°C~65°C
	Ambient humidity	90 % RH in max .(no dewing)
	Height/vibration	Below 1,000 m, below 5.9m/sec <sup>2</sup> (=0.6g)
	Application position	No corrosive gas, inflammable gas, oil mist, dust and others
Cooling		Air-blast cooling

## 2.3 Product List

## One. E100 Series

## (1) Type list

Frequency inverter type	Rated capacity (KVA)	Rated input current (A)	Rated output current (A)	Matchable Motor (kW)
<b>S2 (Single-phase 220V, 50/60Hz) (Built-in Brake Unit)</b>				
CDI-E100G0R4S2B	0.8	5.0	2.3	0.4
CDI-E100G0R75S2B	1.5	9	4.0	0.75
CDI-E100G1R5S2B	2.7	15.7	7.0	1.5
CDI-E100G2R2S2B	3.8	27	10.0	2.2
<b>T2 (Three-phase 220V, 50/60Hz) (Built-in Brake Unit)</b>				
CDI-E100G0R4T2B	0.8	2.6	2.3	0.4
CDI-E100G0R75T2B	1.5	6	4.0	0.75
CDI-E100G1R5T2B	2.7	8.8	7.0	1.5
CDI-E100G2R2T2B	3.8	12.5	10.0	2.2
<b>T4 (Three-phase 380V, 50/60Hz) (15kW and below the standard built-in brake unit)</b>				
CDI-E100G0R75T4B	1.5	4.4	3.0	0.75
CDI-E100G1R5T4B	3.0	6.0	4.5	1.5
CDI-E100G2R2T4B	4.0	6.8	6.0	2.2
CDI-E100G3R7T4B	5.9	11	9.5	3.7
CDI-E100G5R5/P7R5T4B	8.5/11	15.5/20.5	13/17	5.5/7.5
CDI-E100G7R5/P011T4B	11/17	20.5/26	17/25	7.5/11
CDI-E100G011/P015T4BL	17/21	26/35	25/32	11/15
CDI-E100G015/P018.5T4BL	21/24	35/38.5	32/37	15/18.5
CDI-E100G018.5/P022T4	24/30	38.5/46.5	37/45	18.5/22
CDI-E100G022/P030T4	30/40	46.5/62	45/60	22/30
CDI-E100G030/P037T4	40/50	62/76	60/75	30/37
CDI-E100G037/P045T4	50/60	76/92	75/90	37/45
CDI-E100G045/P055T4	60/72	92/113	90/110	45/55
CDI-E100G055/P075T4	72/100	113/157	110/152	55/75
CDI-E100G075/P093T4	100/116	157/180	152/176	75/93
CDI-E100G093/P110T4	116/138	180/214	176/210	93/110
CDI-E100G110/P132T4	138/167	214/256	210/253	110/132
CDI-E100G132/P160T4	167/200	256/305	253/300	132/160
CDI-E100G160/P185T4	200/224	305/344	300/340	160/185
CDI-E100G185/P200T4	224/250	344/383	340/380	182/200
CDI-E100G200/P220T4L	250/276	383/425	380/420	200/220
CDI-E100G220T4L	276	425	420	220
CDI-E100P250T4L	316	484	480	250
CDI-E100G250/P280T4L	316/355	484/543	480/540	250/280
CDI-E100G280/P315T4L	355/395	543/605	540/600	280/315
CDI-E100G315/P355T4L	395/467	605/714	600/680	315/355
CDI-E100G355/P375T4L	447/467	683/714	680/710	355/375
CDI-E100G375T4L	467	714	710	375
CDI-E100P400T4L	494	753	750	400
CDI-E100G400T4L	494	753	750	400
CDI-E100P500T4L	612	934	930	500
CDI-E100G500T4L	612	934	930	500
CDI-E100G630T4L	790	1206	1200	630

## (2) Type configuration

Frequency inverter type	Brake unit	D.C. reactor	LCD keyboard	
T4 (Three-phase 380V, 50/60Hz)				
CDI-E100G0R75T4B	Built-in as standard configuration	N/A	N/A	
CDI-E100G1R5T4B				
CDI-E100G2R2T4B				
CDI-E100G3R7T4B				
CDI-E100G5R5/P7R5T4B				
CDI-E100G7R5/P011T4B				
CDI-E100G011/P015T4BL				Built-in as standard configuration
CDI-E100G015/P018.5T4BL	Built-in as option configuration			
CDI-E100G018.5/P022T4				
CDI-E100G022/P030T4	Built-in as option configuration	External connection as option configuration		
CDI-E100G030/P037T4				
CDI-E100G037/P045T4				
CDI-E100G045/P055T4				
CDI-E100G055/P075T4				
CDI-E100G075/P093T4				
CDI-E100G093/P110T4				
CDI-E100G110/P132T4				
CDI-E100G132/P160T4			External connection as option configuration	Option configuration
CDI-E100G160/P185T4				
CDI-E100G185/P200T4				
CDI-E100G200/P220T4L				
CDI-E100G220T4L				
CDI-E100P250T4L				
CDI-E100G250/P280T4L				
CDI-E100G280/P315T4L				
CDI-E100G315/P355T4L				
CDI-E100G355/P375T4L				
CDI-E100G375T4L				
CDI-E100P400T4L				
CDI-E100G400T4L				
CDI-E100P500T4L				
CDI-E100G500T4L				
CDI-E100G630T4L				

## Two E102 Series

## (1) Type list

Frequency inverter type	Rated capacity (KVA)	Rated input current (A)	Rated output current (A)	Matchable Motor (kW)
<b>S2 (Single-phase 220V, 50/60Hz) (Built-in Brake Unit)</b>				
CDI-E102G0R4S2B	0.8	5.0	2.3	0.4
CDI-E102G0R75S2B	1.5	9	4.0	0.75
CDI-E102G1R5S2B	2.7	15.7	7.0	1.5
CDI-E102G2R2S2B	3.8	27	10.0	2.2
<b>T2 (Three-phase 220V, 50/60Hz) (Built-in Brake Unit)</b>				
CDI-E102G0R4T2B	0.8	2.6	2.3	0.4
CDI-E102G0R75T2B	1.5	6	4.0	0.75
CDI-E102G1R5T2B	2.7	8.8	7.0	1.5
CDI-E102G2R2T2B	3.8	12.5	10.0	2.2
<b>T4 (Three-phase 380V, 50/60Hz) (15kW and below the standard built-in brake unit)</b>				
CDI-E102G0R75T4B	1.5	4.4	3.0	0.75
CDI-E102G1R5T4B	3.0	6.0	4.5	1.5
CDI-E102G2R2T4B	4.0	6.8	6.0	2.2
CDI-E102G3R7T4B	5.9	11	9.5	3.7
CDI-E102G5R5/P7R5T4B	8.5/11	15.5/20.5	13/17	5.5/7.5
CDI-E102G7R5/P011T4B	11/17	20.5/26	17/25	7.5/11
CDI-E102G011/P015T4BL	17/21	26/35	25/32	11/15
CDI-E102G015/P018.5T4BL	21/24	35/38.5	32/37	15/18.5
CDI-E102G018.5/P022T4	24/30	38.5/46.5	37/45	18.5/22
CDI-E102G022/P030T4	30/40	46.5/62	45/60	22/30
CDI-E102G030/P037T4	40/50	62/76	60/75	30/37
CDI-E102G037/P045T4	50/60	76/92	75/90	37/45
CDI-E102G045/P055T4	60/72	92/113	90/110	45/55
CDI-E102G055/P075T4	72/100	113/157	110/152	55/75
CDI-E102G075/P093T4	100/116	157/180	152/176	75/93
CDI-E102G093/P110T4	116/138	180/214	176/210	93/110
CDI-E102G110/P132T4	138/167	214/256	210/253	110/132
CDI-E102G132/P160T4	167/200	256/305	253/300	132/160
CDI-E102G160/P185T4	200/224	305/344	300/340	160/185
CDI-E102G185/P200T4	224/250	344/383	340/380	182/200
CDI-E102G200/P220T4L	250/276	383/425	380/420	200/220
CDI-E102G220T4L	276	425	420	220
CDI-E102P250T4L	316	484	480	250
CDI-E102G250/P280T4L	316/355	484/543	480/540	250/280
CDI-E102G280/P315T4L	355/395	543/605	540/600	280/315
CDI-E102G315/P355T4L	395/467	605/714	600/680	315/355
CDI-E102G355/P375T4L	447/467	683/714	680/710	355/375
CDI-E102G375T4L	467	714	710	375
CDI-E102P400T4L	494	753	750	400
CDI-E102G400T4L	494	753	750	400
CDI-E102P500T4L	612	934	930	500
CDI-E102G500T4L	612	934	930	500
CDI-E102G630T4L	790	1206	1200	630

## (2) Type configuration

Frequency inverter type	Brake unit	D.C. reactor	LCD keyboard
T4 (Three-phase 380V, 50/60Hz)			
CDI-E102G0R75T4B	Built-in as standard configuration	N/A	N/A
CDI-E102G1R5T4B			
CDI-E102G2R2T4B			
CDI-E102G3R7T4B			
CDI-E102G5R5/P7R5T4B			
CDI-E102G7R5/P011T4B			
CDI-E102G011/P015T4BL			
CDI-E102G015/P018.5T4BL			
CDI-E102G018.5/P022T4	Built-in as option configuration	Built-in as option configuration	
CDI-E102G022/P030T4			
CDI-E102G030/P037T4			
CDI-E102G037/P045T4			
CDI-E102G045/P055T4			
CDI-E102G055/P075T4			
CDI-E102G075/P093T4			
CDI-E102G093/P110T4		External connection as option configuration	
CDI-E102G110/P132T4			
CDI-E102G132/P160T4	External connection as option configuration	Built-in as standard configuration	Option configuration
CDI-E102G160/P185T4			
CDI-E102G185/P200T4			
CDI-E102G200/P220T4L			
CDI-E102G220T4L			
CDI-E102P250T4L			
CDI-E102G250/P280T4L			
CDI-E102G280/P315T4L			
CDI-E102G315/P355T4L			
CDI-E102G355/P375T4L			
CDI-E102G375T4L			
CDI-E102P400T4L			
CDI-E102G400T4L			
CDI-E102P500T4L			
CDI-E102G500T4L			
CDI-E102G630T4L			

## Three. E180 Series

## (1) Type list

Frequency inverter type	Rated capacity (KVA)	Rated input current (A)	Rated output current (A)	Matchable Motor (kW)
<b>T2 (Three-phase 220V, 50/60Hz)</b>				
CDI-E180G0R4T2B	1.5	3.4	2.3	0.4
CDI-E180G0R75T2B	3	5.0	4.0	0.75
CDI-E180G1R5T2B	4	5.8	7.0	1.5
CDI-E180G2R2T2B	5.9	10.5	10	2.2
CDI-E180G3R7T2B	8.5	15.5	17	3.7
CDI-E180G5R5T2B	17	26	25	5.5
CDI-E180G7R5T2BL	21	35	32	7.5
CDI-E180G011T2	30	46.5	45	11
CDI-E180G015T2	40	62	60	15
CDI-E180G018.5T2	50	76	75	18.5
CDI-E180G022T2	60	92	90	22
CDI-E180G030T2	72	113	110	30
<b>T4 (Three-phase 380V, 50/60Hz)</b>				
CDI-E180G0R75T4B	1.5	3.4	2.3	0.75
CDI-E180G1R5T4B	3	5.0	3.7	1.5
CDI-E180G2R2T4B	4	5.8	5.1	2.2
CDI-E180G3R7/P5R5T4B	5.9/8.5	10.5/15.5	9.0/13	3.7/5.5
CDI-E180G5R5MT4B	8.5	15.5	13	5.5
CDI-E180G5R5/P7R5T4B	8.5/11	15.5/20.5	13/17	5.5/7.5
CDI-E180G7R5/P011T4B	11/17	20.5/26	17/25	7.5/11
CDI-E180G011MT4B	17	26	25	11
CDI-E180G011/P015T4BL	17/21	26/35	25/32	11/15
CDI-E180G015/P018.5T4BL	21/24	35/38.5	32/37	15/18.5
CDI-E180G018.5/P022T4	24/30	38.5/46.5	37/45	18.5/22
CDI-E180G022/P030T4	30/40	46.5/62	45/60	22/30
CDI-E180G030/P037T4	40/50	62/76	60/75	30/37
CDI-E180G037/P045T4	50/60	76/92	75/90	37/45
CDI-E180G045/P055T4	60/72	92/113	90/110	45/55
CDI-E180G055/P075T4	72/100	113/157	110/152	55/75
CDI-E180G075/P093T4	100/116	157/180	152/176	75/93
CDI-E180G093/P110T4	116/138	180/214	176/210	93/110
CDI-E180G110/P132T4	138/167	214/256	210/253	110/132
CDI-E180G132/P160T4	167/200	256/305	253/300	132/160
CDI-E180G160/P185T4	200/224	305/344	300/340	160/185
CDI-E180G185/P200T4	224/250	344/383	340/380	182/200
CDI-E180G200/P220T4L	250/276	383/425	380/420	200/220
CDI-E180G220T4L	276	425	420	220
CDI-E180P250T4L	316	484	480	250
CDI-E180G250/P280T4L	316/355	484/543	480/540	250/280
CDI-E180G280/P315T4L	355/395	543/605	540/600	280/315
CDI-E180G315/P355T4L	395/467	605/714	600/680	315/355
CDI-E180G355/P375T4L	447/467	683/714	680/710	355/375
CDI-E180G375T4L	467	714	710	375
CDI-E180P400T4L	494	753	750	400
CDI-E180G400T4L	494	753	750	400
CDI-E180P500T4L	612	934	930	500
CDI-E180G500T4L	612	934	930	500
CDI-E180G630T4L	790	1206	1200	630
<b>T6 (Three-phase 690V, 50/60Hz)</b>				
CDI-E180G022/P030T6	36/48	30/40	28/38	22/30

Chapter 2 Product Information

Frequency inverter type	Rated capacity (KVA)	Rated input current (A)	Rated output current (A)	Matchable Motor (kW)
CDI-E180G030/P037T6	48/59	40/49	38/46	30/37
CDI-E180G037/P045T6	59/70	49/59	46/56	37/45
CDI-E180G045/P055T6	70/86	59/72	56/68	45/55
CDI-E180G055/P075T6	86/116	72/97	68/92	55/75
CDI-E180G075/P093T6	116/139	97/116	92/110	75/93
CDI-E180G093/P110T6	139/166	116/139	110/132	93/110
CDI-E180G110/P132T6	166/195	139/163	132/155	110/132
CDI-E180G132/P160T6L	195/227	163/190	155/180	132/160
CDI-E180G160/P185T6L	227/264	190/221	180/210	160/185
CDI-E180G185/P220T6L	264/308	221/258	210/245	185/220
CDI-E180G220/P250T6L	308/347	258/290	245/275	220/250
CDI-E180G250/P280T6L	347/383	290/321	275/305	250/280
CDI-E180G280/P315T6L	383/435	321/364	305/345	280/315
CDI-E180G315/P355T6L	435/491	364/411	345/390	315/355
CDI-E180G355/P400T6L	491/541	411/453	390/430	355/400
CDI-E180G400T6L	541	453	430	400
CDI-E180P500T6L	680	569	540	500
CDI-E180G500T6L	680	569	540	500
CDI-E180P600T6L	793	664	630	600
CDI-E180G600T6L	664	664	630	600
CDI-E180P700T6L	905	758	720	700
CDI-E180G700T6L	905	758	720	700

## (2) Type configuration

Frequency inverter type	Brake unit	D.C. reactor	LCD keyboard
T2 (Three-phase 220V, 50/60Hz)			
CDI-E180G0R4T2B	Built-in as standard configuration	N/A	Option configuration
CDI-E180G0R75T2B			
CDI-E180G1R5T2B			
CDI-E180G2R2T2B			
CDI-E180G3R7T2B			
CDI-E180G5R5T2B			
CDI-E180G7R5T2BL	Built-in as standard configuration		
CDI-E180G011T2	Built-in as option configuration	Built-in as option configuration	
CDI-E180G015T2			
CDI-E180G018.5T2	External connection as option configuration		
CDI-E180G022T2			
CDI-E180G030T2			
T4 (Three-phase 380V, 50/60Hz)			
CDI-E180G0R75T4B	Built-in as standard configuration	N/A	Option configuration
CDI-E180G1R5T4B			
CDI-E180G2R2T4B			
CDI-E180G3R7/P5R5T4B			
CDI-E180G5R5MT4B			
CDI-E180G5R5/P7R5T4B			
CDI-E180G7R5/P011T4B			
CDI-E180G011MT4B			
CDI-E180G011/P015T4BL			
CDI-E180G015/P018.5T4BL	Built-in as standard configuration		
CDI-E180G018.5/P022T4	Built-in as option configuration	Built-in as option configuration	
CDI-E180G022/P030T4			
CDI-E180G030/P037T4			
CDI-E180G037/P045T4	External connection as option configuration		
CDI-E180G045/P055T4			
CDI-E180G055/P075T4			
CDI-E180G075/P093T4			
CDI-E180G093/P110T4			
CDI-E180G110/P132T4			
CDI-E180G132/P160T4	External connection as option configuration		
CDI-E180G160/P185T4			
CDI-E180G185/P200T4			
CDI-E180G200/P220T4L			
CDI-E180G220T4L			
CDI-E180P250T4L			
CDI-E180G250/P280T4L			
CDI-E180G280/P315T4L			
CDI-E180G315/P355T4L			
CDI-E180G355/P375T4L			
CDI-E180G375T4L			
CDI-E180P400T4L			
CDI-E180G400T4L			
CDI-E180P500T4L			
CDI-E180G500T4L			
CDI-E180G630T4L	Built-in as standard configuration		

Chapter 2 Product Information

Frequency inverter type	Rated capacity (KVA)	Rated input current (A)	Rated output current (A)
T6 (Three-phase 690V, 50/60Hz)			
CDI-E180G022/P030T6	External connection as option configuration	External connection as option configuration	Option configuration
CDI-E180G030/P037T6			
CDI-E180G037/P045T6			
CDI-E180G045/P055T6			
CDI-E180G055/P075T6			
CDI-E180G075/P093T6			
CDI-E180G093/P110T6			
CDI-E180G110/P132T6			
CDI-E180G132/P160T6L			
CDI-E180G160/P185T6L			
CDI-E180G185/P220T6L		Built-in as standard configuration	
CDI-E180G220/P250T6L			
CDI-E180G250/P280T6L			
CDI-E180G280/P315T6L			
CDI-E180G315/P355T6L			
CDI-E180G355/P400T6L			
CDI-E180G400T6L			
CDI-E180P500T6L			
CDI-E180G500T6L			
CDI-E180P600T6L			
CDI-E180G600T6L			
CDI-E180P700T6L			
CDI-E180G700T6L			
<b>NOTE: For externally-connected brake unit refers to A2.5, and for externally-connected D.C. reactor refers to A2.2.</b>			

**Order explanation:**

During order, please enter type, specification of the product, and provide parameter, load type, or other information relating to the motor as much as possible. For any special requirement, please consult with technology department of the Company.

2.4 Appearance and installation size

(1) E100, E102 Series  
Model 1

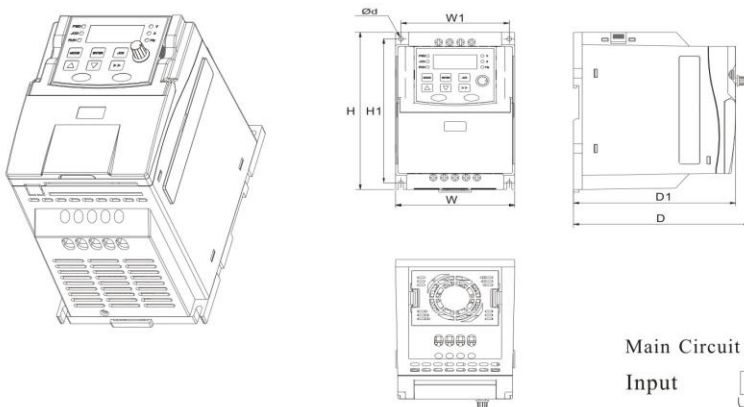

Main Circuit Wiring Diagram:

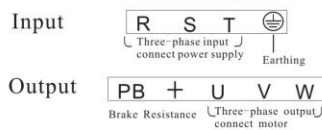

Model	W	W1	H	H1	D	D1	Ød
CDI-E100G0R4S2B	109	99	167	153	161	148	5
CDI-E100G0R75S2B							
CDI-E100G1R5S2B							
CDI-E100G0R4T2B							
CDI-E100G0R75T2B							
CDI-E100G1R5T2B							
CDI-E100G0R75T4B							
CDI-E100G1R5T4B							
CDI-E100G2R2T4B							

Unit:mm

Note:

1. Plastic shell
2. The ordering of the terminals is subject to material object

Model 2

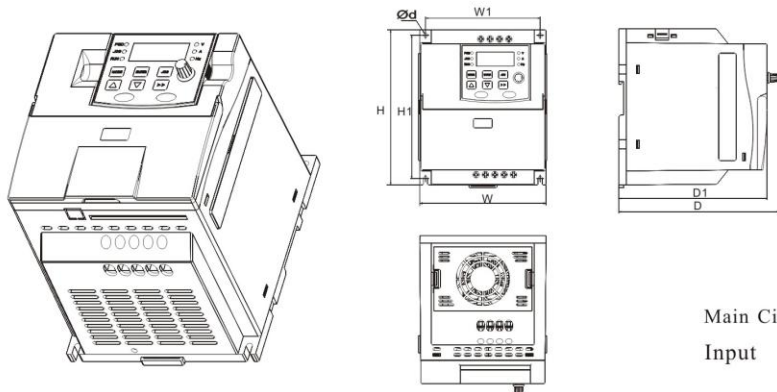

Main Circuit Wiring Diagram:

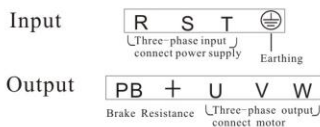

Model	W	W1	H	H1	D	D1	Ød
CDI-E100G2R2S2B	135	122	167	153	171	158	5
CDI-E100G2R2T2B							
CDI-E100G3R7T4B							

Unit:mm

Note:

1. Plastic shell
2. The ordering of the terminals is subject to material object

**Note: the dimension of E102 is same as E100 series**

Model 13

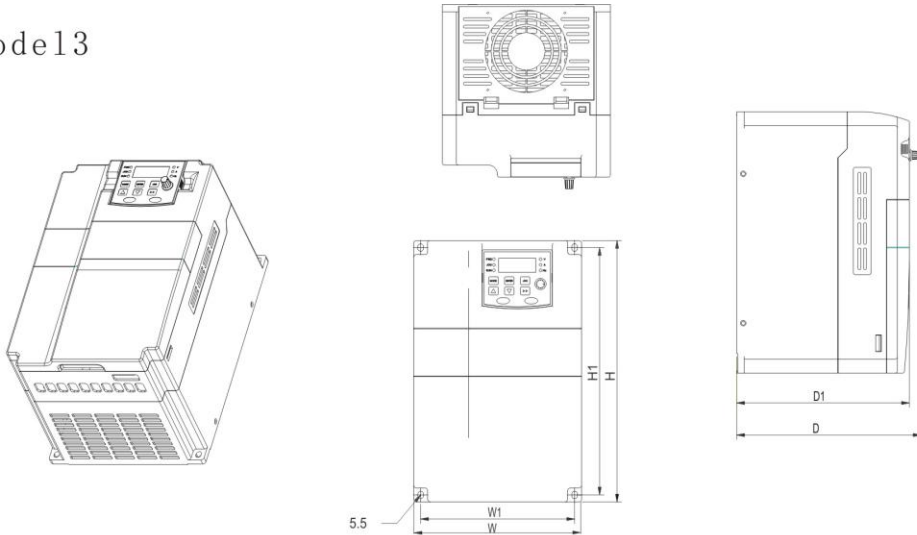

Model	W	W1	H	H1	D	D1	∅d
CDI-E100G5R5/P7R5T4B	180	165	280	265	197.5	185	5.5
CDI-E100G7R5/P011T4B							

Unit:mm

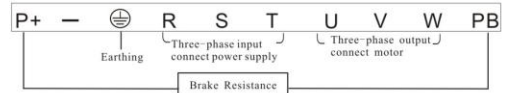

Note:  
The ordering of the terminals is subject to material object

Model 14

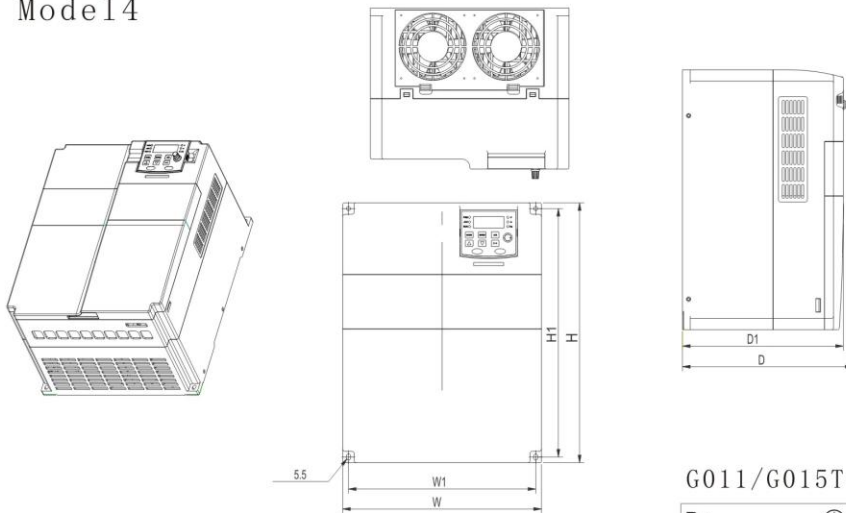

Model	W	W1	H	H1	D	D1	∅d
CDI-E100G011/P015T4BL	230	215	310	295	206	193.5	5.5
CDI-E100G015/P018.5T4BL							
CDI-E100G018.5/P022T4	260	245	340	325	223	210.5	5.5
CDI-E100G022/P030T4							

Unit: mm

G011/G015T4BL

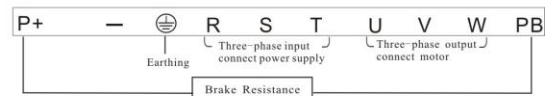

G018.5/G022T4

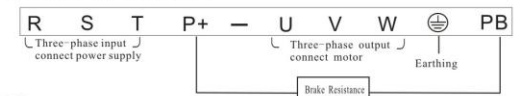

Note:  
The ordering of the terminals is subject to material object

Note: the dimension of E102 is same as E100 series

Model 15

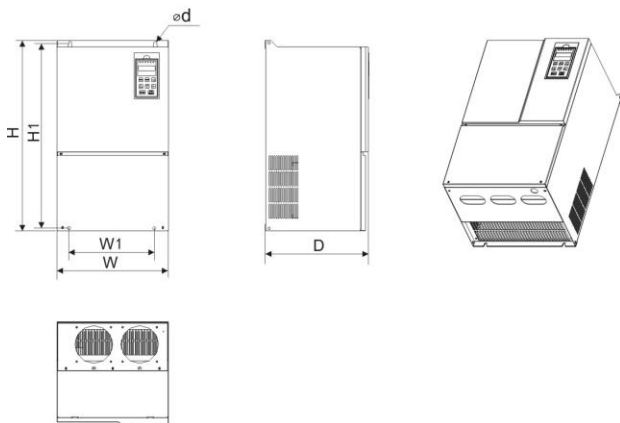

Model	W	W1	H	H1	D	ød
CD1-E100G030/P037T4	250	160	430	415	220	ø7
CD1-E100G037/P045T4						

Unit:mm

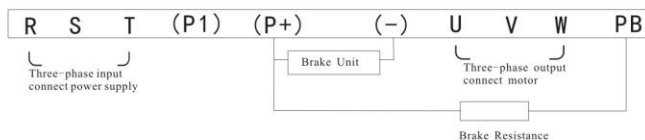

Note:  
The ordering of the terminals is subject to material object

Model 16

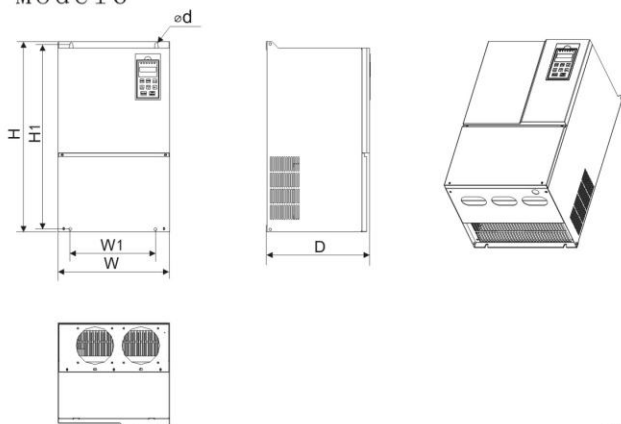

Model	W	W1	H	H1	D	ød
CD1-E100G045/P055T4	300	240	530	515	270	ø9
CD1-E100G055/P075T4						

Unit:mm

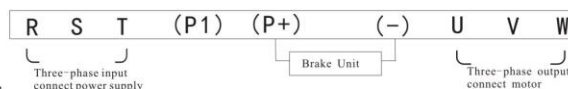

Note:  
The ordering of the terminals is subject to material object

Model 17

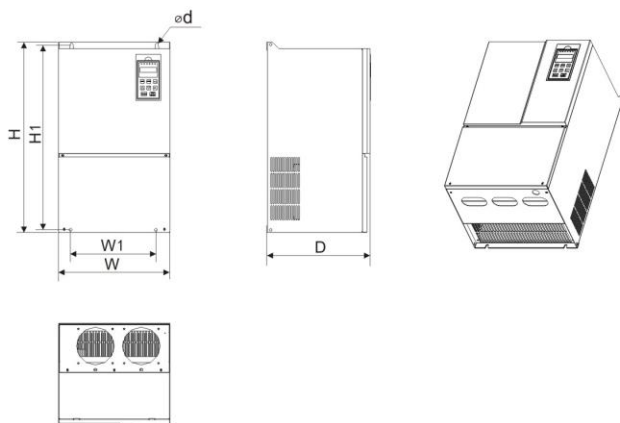

Model	W	W1	H	H1	D	ød
CD1-E100G075/P093T4	340	260	580	565	313	ø9
CD1-E100G093/P110T4						
CD1-E100G110/P132T4						

Unit:mm

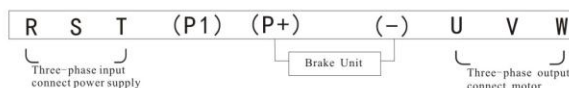

Note:  
The ordering of the terminals is subject to material object

Note: the dimension of E102 is same as E100 series

### Model 18

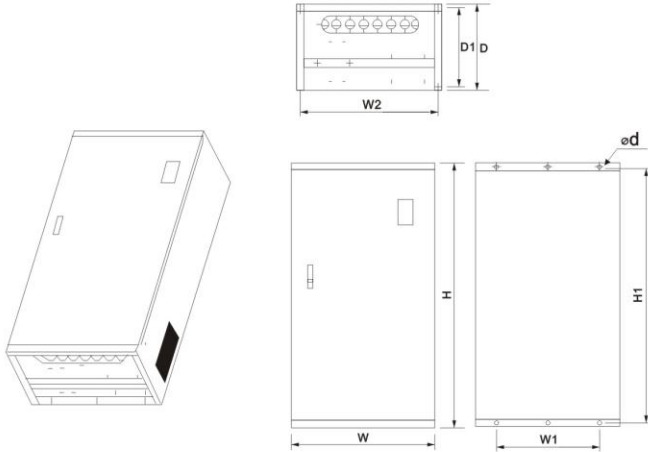

Model	W	W1	W2	H	H1	D	D1	c d
CDI-E100G132/P160T4	400	300	365	940	910	367	336	13
CDI-E100G160/P185T4								
CDI-E100G185/P200T4								

Unit:mm

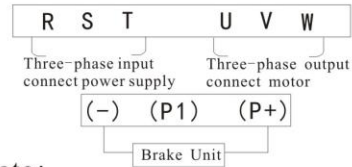

Note:  
The ordering of the terminals is subject to material object

### Model 19

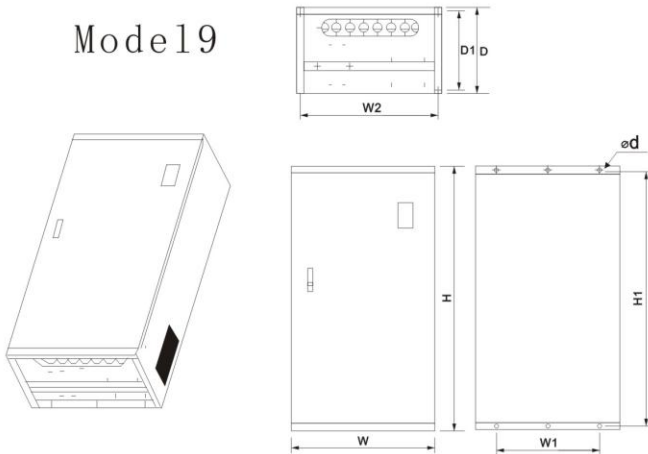

Model	W	W1	W2	H	H1	D	D1	c d
CDI-E100G200/P220T4L	514	400	504	1235	1200	400	360	14
CDI-E100G220/P250T4L								
CDI-E100G250/P280T4L	545	400	504	1345	1310	400	360	14
CDI-E100G280/P315T4L								
CDI-E100G315/P355T4L								
CDI-E100G355/P375T4L	545	400	504	1450	1415	400	360	14
CDI-E100G375/P400T4L								
CDI-E100G400T4L								

Unit:mm

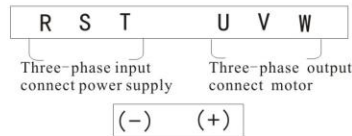

Note:  
The ordering of the terminals is subject to material object

### Model 110

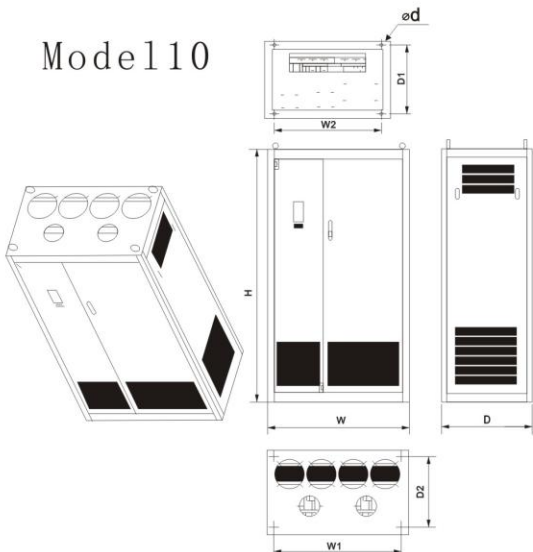

Model	W	W1	W2	H	D	D1	D2	c d
CDI-E100P500T4L	1000	900	850	1600	600	550	500	M16
CDI-E100G500T4L								
CDI-E100G630T4L								

Unit:mm

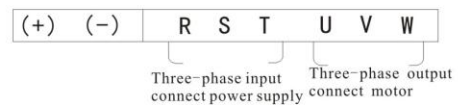

Note:  
The ordering of the terminals is subject to material object

Note: the dimension of E102 is same as E100 series

(2) E180 Series  
Model1

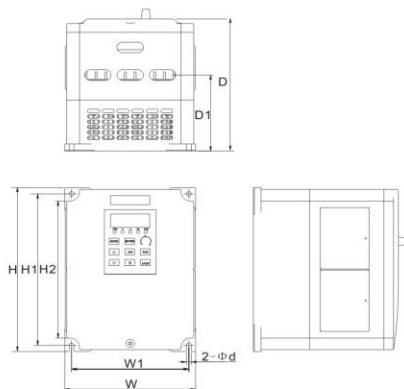

Model	W	W1	H	H1	H2	D	D1	$\phi d$
CD1-E180G0R4T2B	130	120	180	170	154	148	85	5
CD1-E180G0R75T2B								
CD1-E180G0R75T4B								
CD1-E180G1R5T4B								
CD1-E180G2R2T4B								

Unit:mm

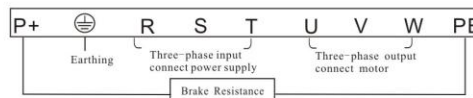

Note:  
The ordering of the terminals is subject to material object

Model2

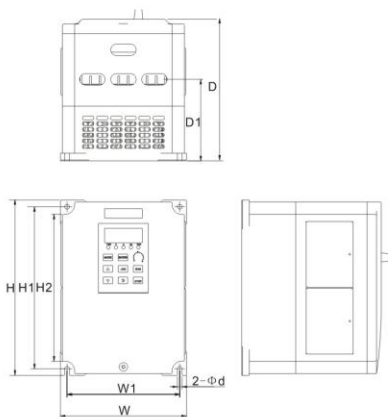
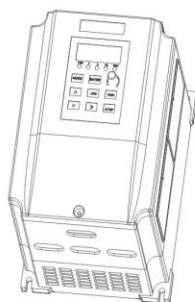

Model	W	W1	H	H1	H2	D	D1	$\phi d$
CD1-E180G1R5T2B	155	145	225	215	199	160	97	5
CD1-E180G2R2T2B								
CD1-E180G3R7/P5R5T4B								
CD1-E180G5R5MT4B								

Unit:mm

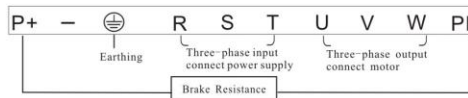

Note:  
The ordering of the terminals is subject to material object

Model3

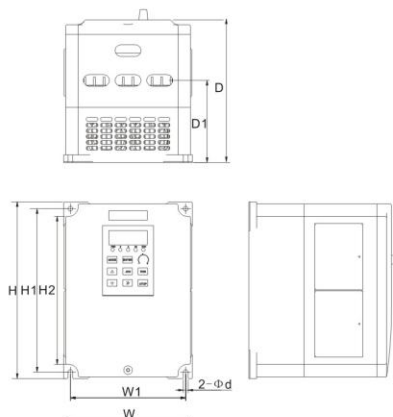

Model	W	W1	H	H1	H2	D	D1	$\phi d$
CD1-E180G3R7T2B	200	188	300	288	270	172	130	6
CD1-E180G5R5/P7R5T4B								
CD1-E180G7R5/P011T4B								
CD1-E180G011MT4B								

Unit:mm

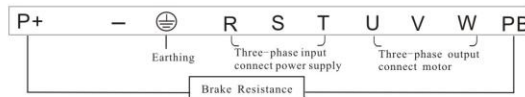

Note:  
The ordering of the terminals is subject to material object

Model 14

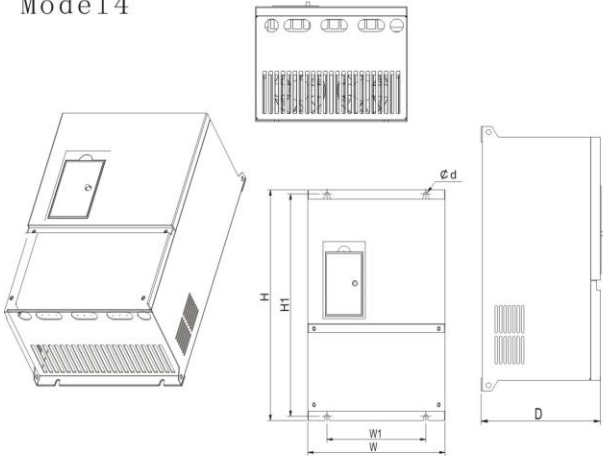

Model	W	W1	H	H1	D	$\phi d$
CD1-E180G5R5T2B	250	180	420	405	189	7
CD1-E180G7R5T2BL						
CD1-E180G011/P015T4BL						
CD1-E180G015/P018.5T4BL						
CD1-E180G011T2	300	190	460	445	209	7
CD1-E180G015T2						
CD1-E180G018.5/P022T4						
CD1-E180G022/P030T4						
CD1-E180G030/P037T4						

Unit:mm

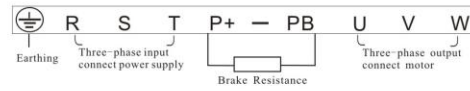

Note:  
The ordering of the terminals is subject to material object

Model 15

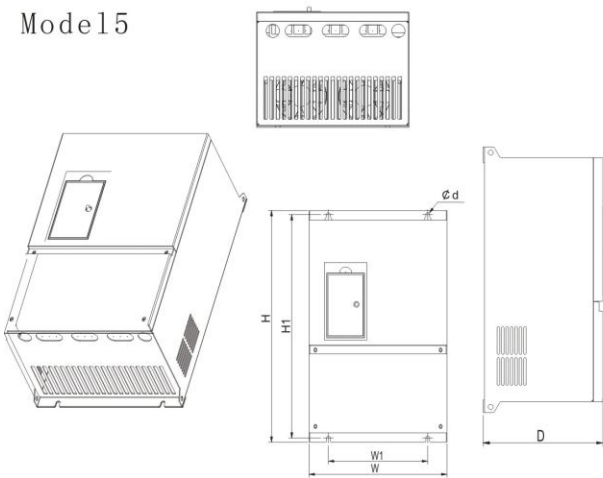

Model	W	W1	H	H1	D	$\phi d$
CD1-E180G018.5T2	355	290	530	515	257	9
CD1-E180G022T2						
CD1-E180G037/P045T4						
CD1-E180G045/P055T4						

Unit:mm



Note:  
The ordering of the terminals is subject to material object

Model 16

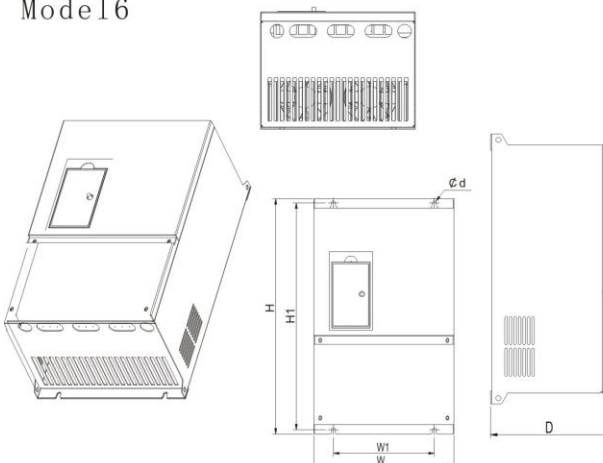

Model	W	W1	H	H1	D	$\phi d$
CD1-E180G030T2	390	290	600	585	257	9
CD1-E180G055/P075T4						
CD1-E180G075/P093T4						
CD1-E180G037/P045T6	400	300	720	690	312	12
CD1-E180G045/P055T6						
CD1-E180G055/P075T6						

Unit:mm

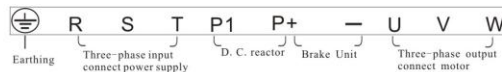

Note:  
The ordering of the terminals is subject to material object

Model17

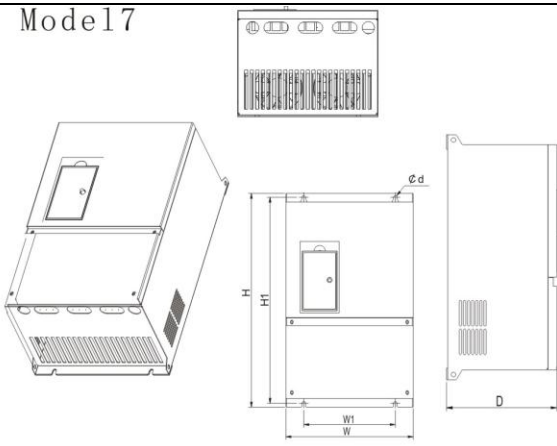

Model	W	W1	H	H1	D	φd
CDI-E180G022/P030T6	355	220	540	525	297	7
CDI-E180G030/P037T6						

Unit:mm

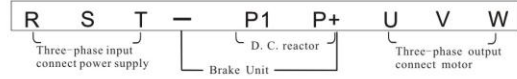

Note:  
The ordering of the terminals is subject to material object

Model18

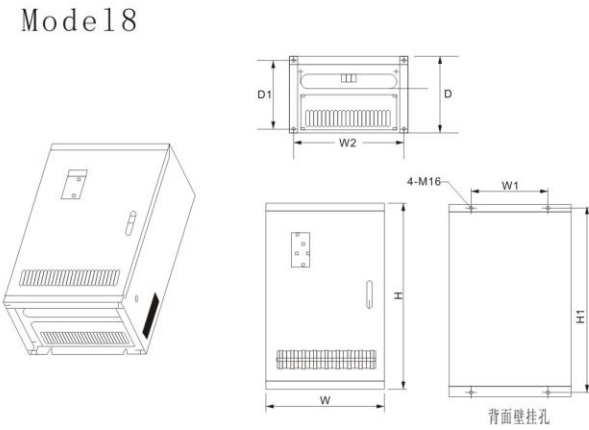

Model	W	W1	W2	H	H1	D	D1	φd
CDI-E180G093/P110T4	470	300	435	750	720	305	270	13
CDI-E180G110/P132T4								

Unit:mm

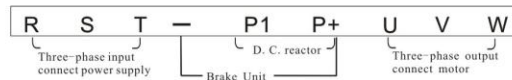

Note:  
The ordering of the terminals is subject to material object

Model19

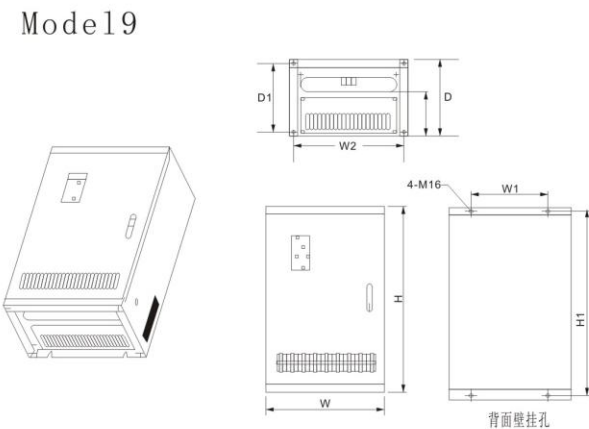

Model	W	W1	W2	H	H1	D	D1	φd
CDI-E180G132/P160T4								
CDI-E180G160/P185T4	530	350	495	950	920	375	345	13
CDI-E180G185/P200T4								
CDI-E180G075/P093T6								
CDI-E180G093/P110T6	540	420	505	1000	970	360	330	14
CDI-E180G110/P132T6								

Unit:mm

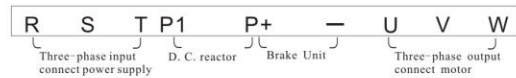

Note:  
The ordering of the terminals is subject to material object

Chapter 2 Product Information

Model 110

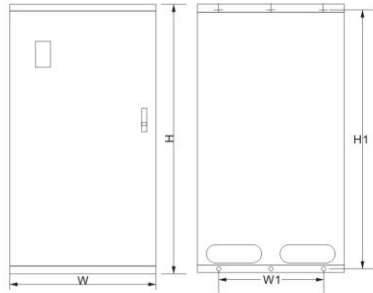
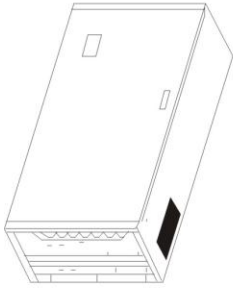
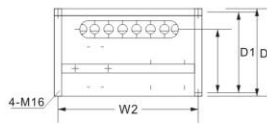

Model	W	W1	W2	H	H1	D	D1	c d
CDI-E180G200/P220T4L	620	450	580	1250	1210	420	380	15
CDI-E180G220/P250T4L								

Unit:mm

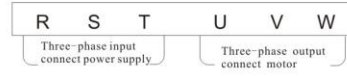

Note:  
The ordering of the terminals is subject to material object

Model 111

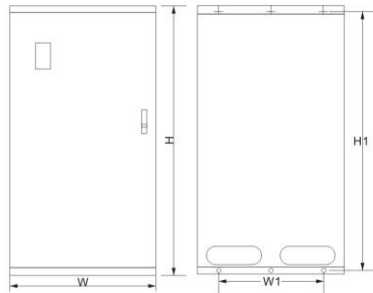
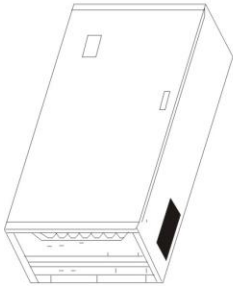
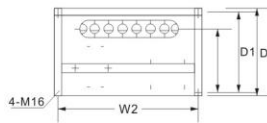

Model	W	W1	W2	H	H1	D	D1	c d
CDI-E180G250/P280T4L	700	500	600	1400	1360	420	380	15
CDI-E180G280/P315T4L								
CDI-E180G315/P355T4L								

Unit:mm

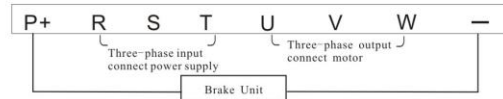

Note:  
The ordering of the terminals is subject to material object

Model 112

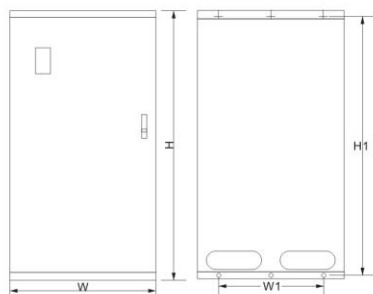
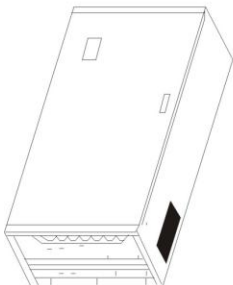
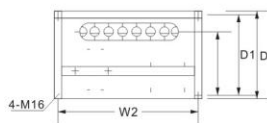

Model	W	W1	W2	H	H1	D	D1	c d
CDI-E180G132/P160T6L	540	420	496	1170	1130	400	360	13
CDI-E180G160/P185T6L								
CDI-E180G185/P220T6L								
CDI-E180G220/P250T6L								
CDI-E180G250/P280T6L								

Unit:mm

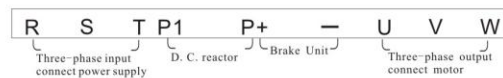

Note:  
The ordering of the terminals is subject to material object

Model 113

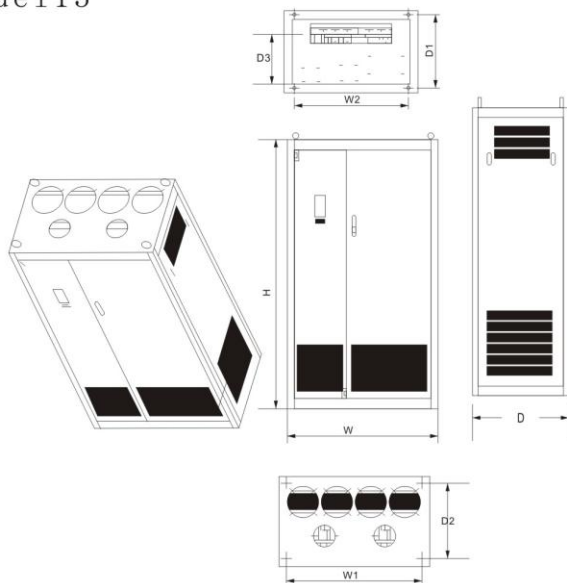

Model	W	W1	W2	H	D	D1	D2	D3	φd
CDI-E180G355/P375T4L									
CDI-E180G375/P400T4L									
CDI-E180G400/P500T4L	1000	900	850	1800	600	550	500	300	16
CDI-E180G375/P400T4L									
CDI-E180P400T4L									
CDI-E180G500T4L									
CDI-E180G630T4L									
CDI-E180G280/P315T6L									
CDI-E180G315/P355T6L	800	700	700	1800	600	500	500	390	16
CDI-E180G355/P400T6L									
CDI-E180G400T6L									
CDI-E180P500T6L									
CDI-E180G500T6L									
CDI-E180P600T6L	1000	900	850	1800	600	550	500	436	16
CDI-E180G600T6L									
CDI-E180P700T6L									
CDI-E180G700T6L									

Unit:mm

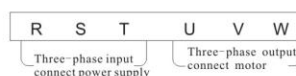

Note :

The ordering of the terminals is subject to material object

2.5 Routine maintenance

(1) Routine maintenance

Under influence of temperature, humidity, dust and vibration, internal elements of frequency inverter should be aged, which should cause potential fault, or decrease service life of frequency inverter. Therefore, it is significant to perform routine maintenance and regular inspection with the frequency inverter.

Routine maintenance item:

- A. If running sound of motor is abnormal.
- B. If vibration is created during operation of motor.
- C. If installing condition of frequency inverter is changed.
- D. If radiating fan of frequency inverter works normally.
- E. If frequency inverter is in state of overheat.

Daily cleanness:

- A. Keep cleanness of frequency inverter.
- B. Remove dust from surface of frequency inverter effectively, to prevent frequency inverter from incursion of dust, or metal dust.
- C. Remove oil sludge form radiating fan of frequency inverter effectively.

(2) Regular inspection

Please inspect corner pockets of frequency inverter regularly.

Regular inspection item:

- A. Inspect air flue, and clean it regularly.
- B. Inspect if screw is loosened.
- C. Inspect if frequency inverter is corrosive.
- D. Inspect if there is arc on surface connecting terminal.
- E. Insulated test of major loop

Note: Please disconnect major loop and frequency inverter while testing insulation resistance by using megohmmeter (500V DC megohmmeter). Do not measure insulation of control loop with megohmmeter. And high voltage test is needless (finished in ex works).

(3) Replacement of wearing parts

Wearing parts of frequency inverter includes cooling fan, filter ELCC, of which service life depend on operating environment and maintenance condition closely.

User could confirm replacement period according to the operating time.

A. Cooling fan

Potential damage reason: Shaft abrasion and vane aging.

Critical standard: If there is crack on vane of fan, or if abnormal sound occurs during starting.

B. Filter ELCC

Potential damage reason: Bad input power, higher ambient temperature, frequent load switch, or aging of electrolyte. Critical standard: If liquid leaks, if safety valve bulged out, measure of static capacitance, and measure of insulated resistance.

(4) Storage of frequency inverter

After purchased the device, please pay attention to following points while storing it:

- A. Please store it in original package as much as possible.
- B. Long term storage should cause aging of ELCC, please electrify it for 5 hours above twice a year during storing, in mode of raising voltage to rated voltage slowly via transformer.

(5) Guarantee of frequency inverter

Maintenance free is limited to the frequency inverter only.

The Company will provide guaranteed repair for fault or damage occurs during normal application. For device sold, shall be repaired in China in reference to the bar code date, and for exported device (not included China) shall be repaired at purchase site if the date is within six months after delivery.

For products manufactured by the Company, we will provide paid service for life anytime, or anywhere applied it.

All sale, product, and agent units of the Company should provide products with after sale service, of which service terms include:

- A. Provide “Class III” inspection service at site of the unit. (Include fault elimination)
- B. Refer to after sell service contract concluded between the Company and agents.
- C. Request for compensated after-sell service from the agent of the Company (without reference to guaranteed repair).

Our Company should take responsibility of guaranteed repair, guaranteed exchange, and guaranteed return for quality and accident responsibility relating to the product, but user could affect insurance for further responsibility compensation guarantee from insurance agent.

**Guarantee term of the product should be effective in 18 months after Bar code date.**

For fault caused in following reason, user could obtain compensated maintenance only even guarantee term is effective:

- A. Problem caused in incorrect operation (based on user’s manual) or repair, modification without authorization.
- B. Problem caused in violation of critical requirement.
- C. Damage caused in undeserved transportation after purchased.
- D. Aging or fault caused in bad environment.
- E. Damage caused in earthquake, fire, disaster, lightning strike, abnormal voltage or other natural disaster and incidental disaster.
- F. Damage occurs in transportation. (Note: transportation mode should be appointed by user of themselves, the Company should assist agent to conduct transfer of goods).
- G. Brand, trade mark, SN, nameplate marked by manufacturer is damaged or unjustifiable.
- H. Failure to pay off fund according to purchase contract.
- I. Failure to describe actual conditions relating to installation, distribution, operation, maintenance, or other condition to the Company.

The Company should carry out responsibility of “Three guarantee” abovementioned only after received the returned goods, and confirmed responsibility attribution.

Should it involve an unpaid or untimely settlement due to the buyer, the ownership hereof still belongs to the supplier. In addition, the latter will assume no liability hereinabove, and the buyer shall have no disagreement.

All relevant service fees shall be calculated in accordance with the identical standards of the factory. In the event that an agreement or a contract exist, its priority shall be performed.

## Chapter 3 Installation and Connection of Frequency inverter

### 3.1 Option of the Site and Space for Installation

Option of installing position:

 Warning	1. Prevent from sunniness; Don't use in the open air directly.
	2. Don't use in the corrosive gas and liquid environment.
	3. Don't use in the oil fog and splash environment.
	4. Don't use in the salt spray environment.
	5. Don't use in the moist and rain environment.
	6. Please equip the unit with filters device if metal dust or fiber wadding existing in air.
	7. Do not use the unit in mechanical shock or vibration condition.
	8. It is necessary to adopt cooling measure if ambient temperature is higher than 40°C.
	9. It is recommended to use the unit in temperature range of -10°C~+40°C because fault maybe occur in overcool or overheat condition.
	10. Keep the unit away from power supply noise, high-power application, such as electric welder should impact application of the unit.
	11. Emissive material should impact application of the unit.
	12. Keep the unit away from combustibile material, attenuant and solvent.

For ensuring perfect performance and long-term service life, please comply with the abovementioned advices while installing E Series Frequency inverter to prevent the unit from damage.

Option of the installation space:

For vertical installation of E Series Frequency inverters, adequate cooling room should be left, so as to ensure effective cooling

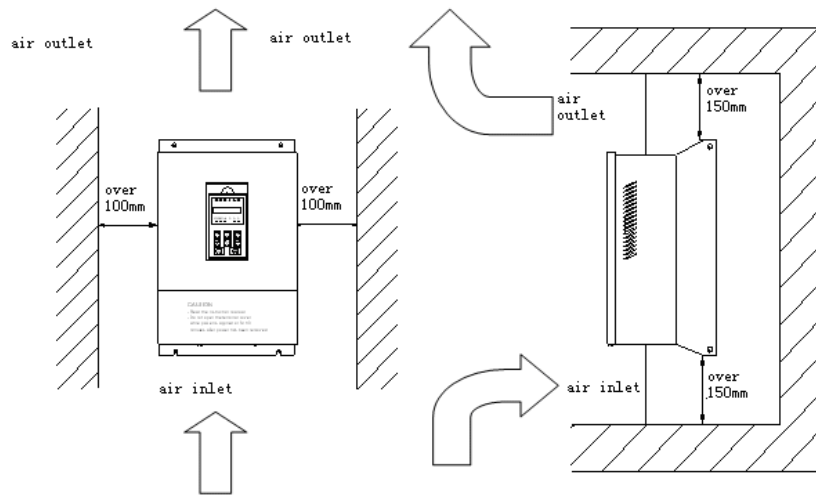

Installation space of E frequency inverters

 Attention	1. The spaces to be left above/below and on the two sides of the frequency inverter are required both for the model with open bracket (IP00) and that with closed bracket (IP20)
	2. Permissible temperature at the air inlet: -10°C ~ +40°C
	3. Adequate cooling spaces should be reserved both above and below the frequency inverter, so as to facilitate gas admission and emission.
	4. Do not drop anything into the air passage during installation. Otherwise the fan might be damaged.
	5. Mount filtering devices at the air inlet in cases of floating fiber or cotton or heavy dust.

### 3.2 Wiring of the Peripherals and Optional parts

The standard method to connect E Series Peripheral Equipment and Optional Components is as below:

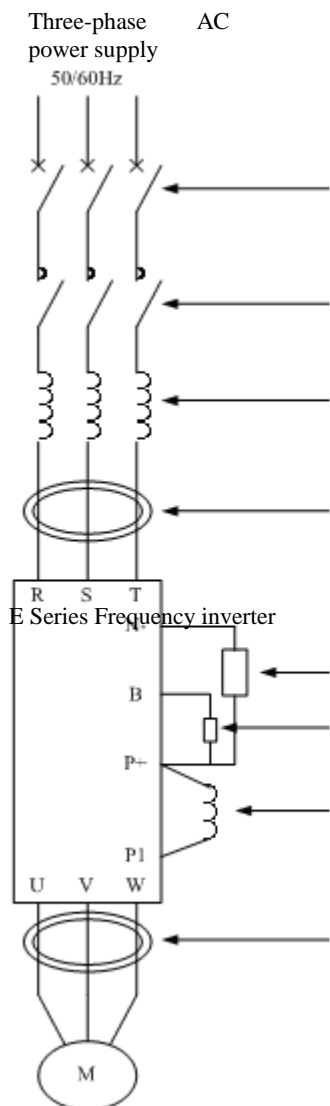



Peripherals and Optional parts	Description
Moulded Case Circuit Breaker (MCCB)	Be used for rapidly cutting off the fault current of the frequency inverter and preventing fault of power supply from the frequency inverter and its line fault
Electromagnetic Contactor (MC)	When the frequency inverter breaks down, cut off main power supply and prevent restart after power off and fault
AC Reactor (ACL)	Be used for improving input power factor, reduce upper harmonics and restrain the power surge
Radio Noise Filter (NF)	Be used for reducing radio noise filter of the frequency inverter
Brake Unit (Ub)	When the brake torque is unable to meet the requirements, this is selected and used for occasions with large inertia load or frequent brake or rapid stop (CDI-E100, E102 Series has built in brake unit. Built-in brake unit for CDI-E180 Series with power below 15Kw and option for the models with power 18.5 kW ~ 30 kW)
Brake Resistance (Rb)	
DC Reactor (DCL)	Be used for improving power factor and restraining current peak (E100, T102 has no this connection terminal)
Radio Noise Filter (NF)	Be used for reducing radio noise filter of the frequency inverter

### 3.3 Wiring of the main circuit

#### 3.3.1 Wiring diagram for the main circuit and precautions

This section describes connection of main circuit of E frequency inverters.

 Dangerous	1. Do not make power supply of AC main loop connect with output terminal U, V, and W.
	2. Please connect unit only after shut down the power supply.
	3. Verify if the crating voltage of frequency inverter is same as the input voltage of it.
	4. Do not perform withstand test with frequency inverter.
	5. Fasten terminal screw with appointed fasten torque.

 Attention	1. Please check if grounding terminal is grounded before connect main loop. (Refer to 3.5)
	2. Terminal sequence should base on actual object.
	3. Rated input voltage: 220V (AC single phase), frequency: 50/60Hz 220V (AC three-phase), frequency: 50/60Hz 380V (AC three-phase), frequency: 50/60Hz 690V (AC three-phase), frequency: 50/60Hz
	4. Allowable fluctuation voltage: +10% (fluctuation $\pm 15\%$ )
	Allowable fluctuation Frequency: $\pm 2\%$

Wiring Diagram of Main Circuit of Model 1、2 of Machine Type E100、E102.

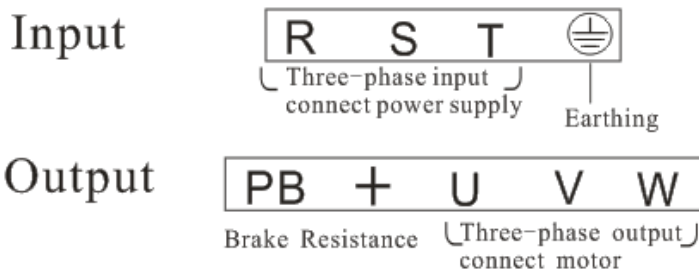

Wiring Diagram of Main Circuit of Model 3 of Machine Type E100、E102

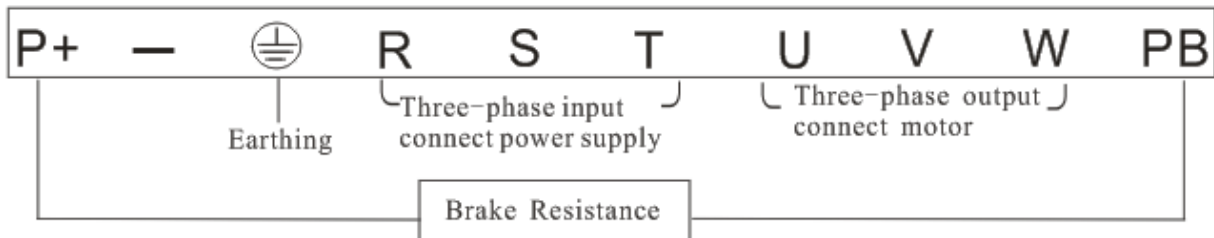

Wiring Diagram of Main Circuit of Model 4 of Machine Type E100、E102

G011/G015T4BL

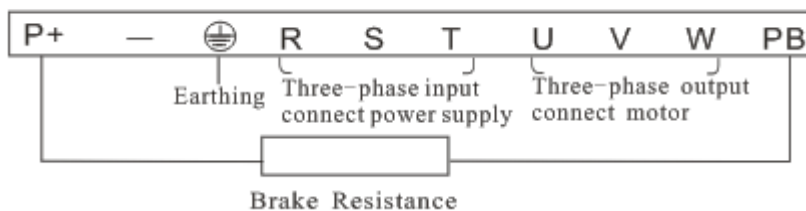

G018.5/G022T4

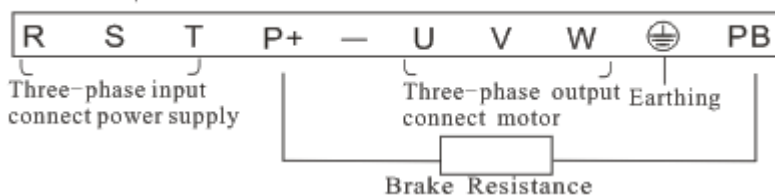

Wiring Diagram of Main Circuit of Model 5 of Machine Type E100、E102

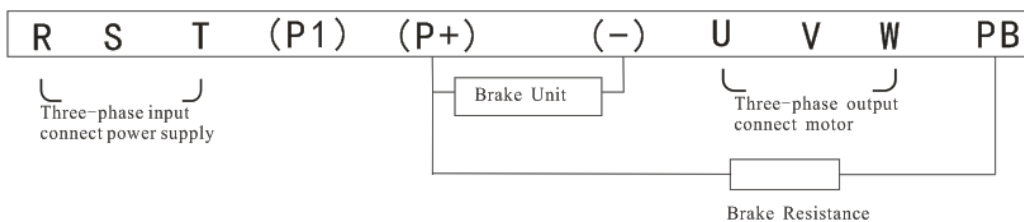

Wiring Diagram of Main Circuit of Model 6、7 of Machine Type E100、E102

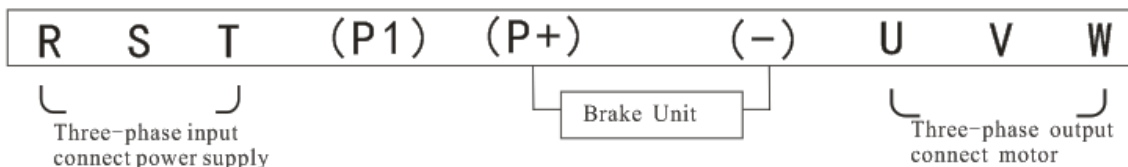

Wiring Diagram of Main Circuit of Model 8 of Machine Type E100、E102

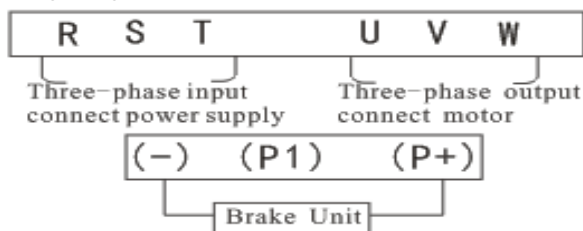

Wiring Diagram of Main Circuit of Model 9 of Machine Type E100、E102

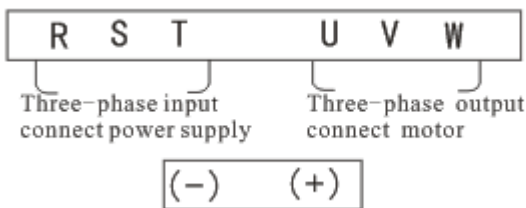

Wiring Diagram of Main Circuit of Model 10 of Machine Type E100、E102

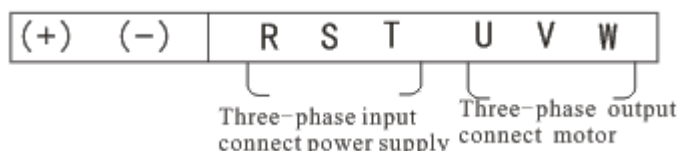

Wiring Diagram of Main Circuit of Model 1 of Machine Type E180

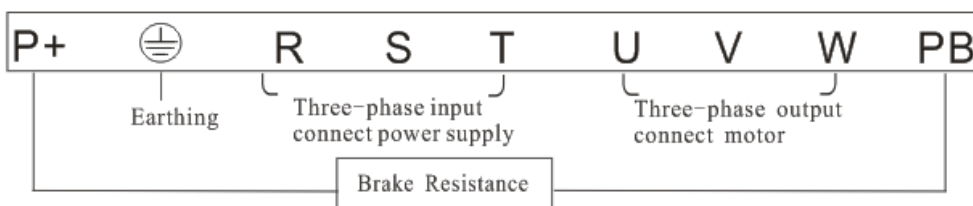

Wiring Diagram of Main Circuit of Model 2、3 of Machine Type E180

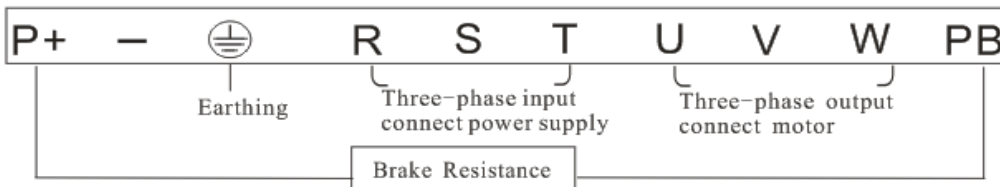

Wiring Diagram of Main Circuit of Model 4 of Machine Type E180

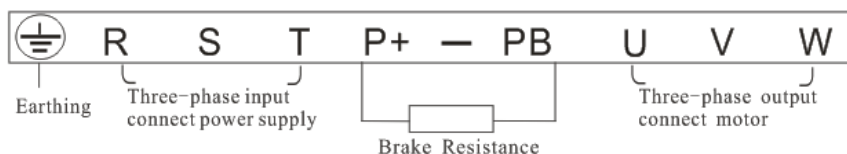

Wiring Diagram of Main Circuit of Model 5 of Machine Type E180

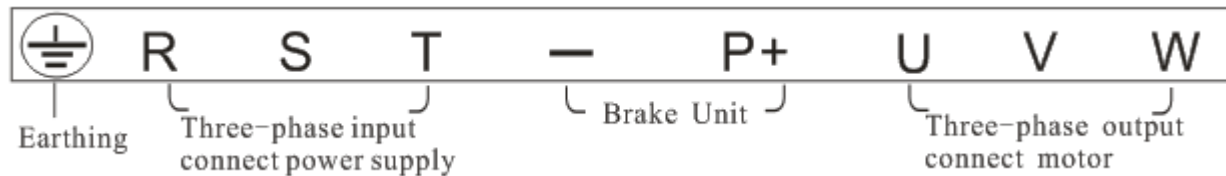

Wiring Diagram of Main Circuit of Model 6 of Machine Type E180

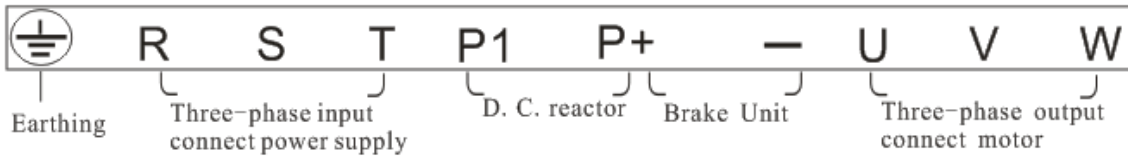

Wiring Diagram of Main Circuit of Model 7、 8 of Machine Type E180

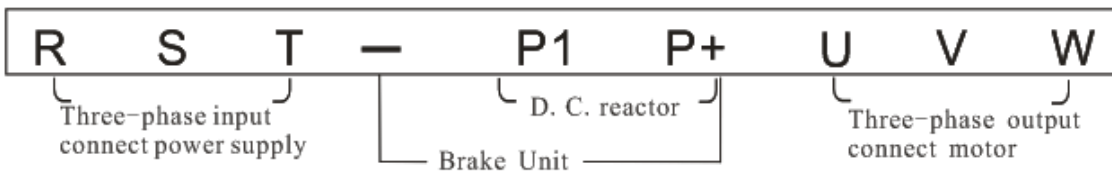

Wiring Diagram of Main Circuit of Model 9、 12 of Machine Type E180

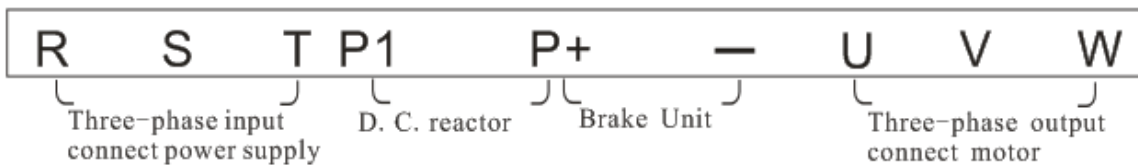

Wiring Diagram of Main Circuit of Model 10、 13 of Machine Type E180

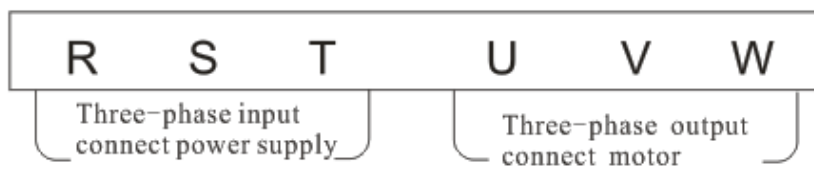

Wiring Diagram of Main Circuit of Model 11 of Machine Type E180

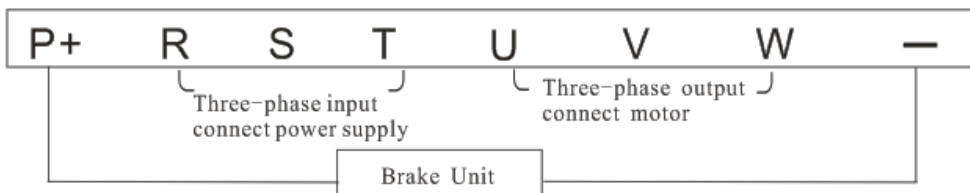

3.3.2 Precautions for wiring the input side of the main circuit

1. Installation for Circuit Breaker (MCCB)

To protect the circuit, a MCCB or fuse should be installed between the power supply of the AC main circuit and the input terminals of R, S, or T.

2. Residual current circuit breaker

When selecting residual current circuit breakers for connection to input terminals of R, S, or T, the one that is not affected by Highest Frequency is preferred, in order to avoid any possible misoperation.

For example: NV series (manufactured in 1988 or later on) by Mitsubishi Electric;

EG and SG series (manufactured in 1984 or later on) by Fuji Electric;

CDM1 Series Circuit Breakers made by DELIXI Group Co., Ltd.

3. Installation of the electromagnetic contactor (MC)

The frequency inverter may be used even if no electromagnetic contactor is installed on the power supply side.

Electromagnetic contactor can take the place of MCCB for the sequence break of the main circuit. However, when the primary side is switched off, the regeneration brake will not function and the motor will stop running.

When the primary side is closed/open, the electromagnetic contactor can cause loads to start/stop, but frequent close/open will lead to frequency inverter fault. Therefore, while using the brake resistor unit, you can always

realize sequential control through the trip contact of the overload relay when the electromagnetic contactor is switched off.

#### 4. Phase sequence connection of the terminals

The phase lines of the input power supply can be connected to any one of the terminals R, S or T on the terminal board, regardless of phase sequences.

#### 5. AC reactor

When a frequency inverter is connected to a large-capacity power transformer (600KVA or beyond), or when a phase lead capacitor (power factor compensator) is connected or disconnected, the peak current through the input power circuit will be so strong that it will damage the rectifier-frequency inverter. Installing a DC reactor (optional) in the frequency inverter or adding an AC reactor (optional) at the input end can effectively improve the power factors at the power supply side.

#### 6. Surge absorber

If a perceptual load (such as electromagnetic contactor, relay, solenoid valve, electromagnetic coil, electromagnetic brake and so on) is connected in the adjacent area, a surge suppressor should also be used while operating the frequency inverter.

#### 7. Setting of a noise filter at the power supply side

Noise filter can be used to reduce the high-frequency noise flowing from the frequency inverter to the power supply.

Wiring example 1: please use noise filters exclusively designed for frequency inverters.

It is set as follows:

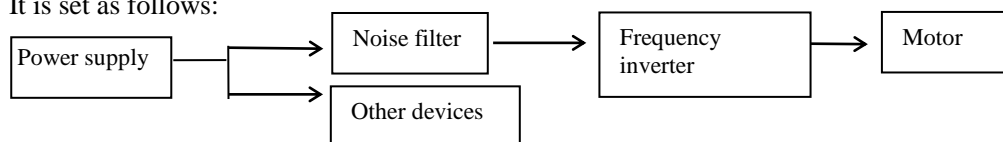

### 3.3.3 Precautions for wiring the output side of the main circuit

#### 1. Connection of the output terminals to the load

Connect the output terminals U, V and W respectively to the leading-out wires U, V and W of the motor. Use the forward rotation instruction for verification. (CCW: observed from the load side, the motor runs counterclockwise). If the motor is not running in the right direction, switch any two of terminals U, V and W.

#### 2. It is absolutely forbidden to connect input power supply to terminals U, V or W!!!

#### 3. Short circuit or grounding of the output circuit is forbidden.

Refrain from directly touching the output circuit or bringing the output wire in contact with the chassis of the frequency inverter. Otherwise, electric shock or grounding fault might occur. In addition, always guard the output wire against short circuit.

#### 4. It is forbidden to connect phase-lead capacitors or LC/RC noise filters

Do not connect phase-lead capacitor or LC/RC noise filters to the output circuit.

#### 5. Refrain from installing magnetic starter

If a magnetic starter or electromagnetic contactor is connected to the output circuit, the frequency inverter will trigger the operation of over-current protection circuit because of the surge current resultant from the frequency inverter's connection to the load. The magnetic contactor should not operate until the frequency inverter has stopped outputting.

#### 6. Installation of thermal overload relay

The frequency inverter consists of an electronic overload protection mechanism. Admittedly, a thermal over-load relay should be installed when a frequency inverter is used in driving several motors or when a multi-pole motor is used. In addition, the rated current of the thermal over-load relay should be the same as the current indicated on the nameplate of the motor.

#### 7. Setting of noise filter on the output side

Mounting a special-purpose noise filter on the output side of the frequency inverter can reduce radio noise and interfering noise.

**Interfering noise:** because of electromagnetic interference, the noise might affect the signal line and result in the misoperation of the controller.

**Radio noise:** the noise can be produced from radio transmitters because of high-frequency waves emitted from the frequency inverter or cables.

#### 8. Countermeasures for interfering noise

Aside from using noise filters, threading all the connecting wires into a ground metal pipe can also restrain interfering noise generated at the output terminal. If we put signal lines over 30cm away, the effect of interfering noise will be abated.

#### 9. Countermeasures for radio noise

Aside from input and output wires, the frequency inverter itself also emits noise. It will help to handle the problem

### Chapter 3 Installation and Connection of Frequency inverter

if we install noise filters at the input and output sides of the frequency inverter or apply shielded lines to the iron case of the frequency inverter. It is also very important to make sure that the connecting wire between the frequency inverter and the motor should be as short as possible

10. The wire distance between the frequency inverter and the motor

If the total wire length between the frequency inverter and the motor is too long or the carrier frequency of the frequency inverter (primary IGBT switch frequency) is rather high, the harmonic leakage current from the cables will exert negative influence on the frequency inverter and other external devices.

If connection line between the frequency inverter and the motor is too long, carrier frequency of the frequency inverter can be reduced as below. The carrier frequency can be given by Function Code P1.0.22.

Table of wire distance between the frequency inverter and the motor

Wire distance between the frequency inverter and the motor	Carrier frequency (P)
Not exceeding 50m	10KHz or lower
Not exceeding 100m	5KHz or lower
Beyond 100m	3KHz or lower

Output reactors should be installed when the wire distance exceeds 50 meters. Otherwise, the motor may get burnt down.

External thermal relays may cause unnecessary operations due to the Highest Frequency current from the distributed capacitance in the output lines of the frequency inverter. As far as Low-capacity models of the 400V Series (especially those below 7.5KW) is concerned, the ratio of their current to the rated current of the frequency inverter will become bigger if their wiring lines are rather long (over 50m). As a result, external thermal relays may carry out unnecessary operations.

#### 3.3.4 Wiring and Supporting Peripherals for Main Circuits

(1) E100、E102 Series

Type of Frequency inverter	Main Circuit Wire Gage (mm <sup>2</sup> )	Control Circuit Wire Gage (mm <sup>2</sup> )	Use-free air breaker MCCB(A)	Electromagnetic contactor MC(A)
<b>S2 (Single Phase 220V)</b>				
CDI-E100G0R4S2B	2.5	1.0	16	10
CDI-E100G0R75S2B	2.5	1.0	16	10
CDI-E100G1R5S2B	2.5	1.0	20	16
CDI-E100G2R2S2B	4.0	1.0	32	20
<b>T2 (Three-phase 220V)</b>				
CDI-E100G0R4T2B	2.5	1.0	10	10
CDI-E100G0R75T2B	2.5	1.0	16	10
CDI-E100G1R5T2B	2.5	1.0	16	10
CDI-E100G2R2T2B	4.0	1.0	25	16
<b>T4 (Three-phase 380V)</b>				
CDI-E100G0R75T4B	2.5	1.0	10	10
CDI-E100G1R5T4B	2.5	1.0	16	10
CDI-E100G2R2T4B	2.5	1.0	16	10
CDI-E100G3R7T4B	4.0	1.0	25	16
CDI-E100G5R5/P7R5T4B	4.0	1.0	32	25
CDI-E100G7R5/P011T4B	4.0	1.0	40	32
CDI-E100G011/P015T4BL	4.0	1.0	63	40
CDI-E100G015/P018.5T4BL	6.0	1.0	63	40
CDI-E100G018.5/P022T4	6.0	1.0	63	40
CDI-E100G022/P030T4	10	1.0	100	63
CDI-E100G030/P037T4	16	1.5	125	100
CDI-E100G037/P045T4	16	1.5	160	100
CDI-E100G045/P055T4	25	1.5	200	125
CDI-E100G055/P075T4	35	1.5	200	125
CDI-E100G075/P093T4	50	1.5	250	160
CDI-E100G093/P110T4	70	1.5	250	160
CDI-E100G110/P132T4	120	1.5	350	350
CDI-E100G132/P160T4	150	1.5	400	400

Type of Frequency inverter	Main Circuit Wire Gage (mm <sup>2</sup> )	Control Circuit Wire Gage (mm <sup>2</sup> )	Use-free air breaker MCCB(A)	Electromagnetic contactor MC(A)
CDI-E100G160/P185T4	185	1.5	500	400
CDI-E100G185/P200T4	185	1.5	500	400
CDI-E100G200/P220T4L	300	1.5	600	600
CDI-E100G220T4L	300	1.5	600	600
CDI-E100G250/P280T4L	370	1.5	800	600
CDI-E100G280/P315T4L	370	1.5	800	800
CDI-E100G315/P355T4L	450	1.5	800	800
CDI-E100G355/P375T4L	450	1.5	800	800
CDI-E100G375T4L	600	1.5	1000	800
CDI-E100P400T4L	600	1.5	1000	1000
CDI-E100G400T4L	600	1.5	1000	1000
CDI-E100P500T4L	600	1.5	1600	1000
CDI-E100G500T4L	600	1.5	1600	1000
CDI-E100G630T4L	600	1.5	1600	1600

**Note: The peripheral configurations of E102 series inverter described in the Table above are same as those of E100 series inverter.**

(2) E180 Series

Type of Frequency inverter	Main Circuit Wire Gage (mm <sup>2</sup> )	Control Circuit Wire Gage (mm <sup>2</sup> )	Use-free air breaker MCCB(A)	Electromagnetic contactor MC(A)
<b>T2 (Three-phase 220V, 50/60Hz)</b>				
CDI-E180G0R4T2B	2.5	1.0	10	10
CDI-E180G0R75T2B	2.5	1.0	16	10
CDI-E180G1R5T2B	2.5	1.0	16	10
CDI-E180G2R2T2B	4.0	1.0	25	16
CDI-E180G3R7T2B	4.0	1.0	32	25
CDI-E180G5R5T2B	4.0	1.0	63	40
CDI-E180G7R5T2BL	6.0	1.0	63	40
CDI-E180G011T2	10	1.5	100	63
CDI-E180G015T2	16	1.5	125	100
CDI-E180G018.5T2	16	1.5	160	100
CDI-E180G022T2	25	1.5	200	125
CDI-E180G030T2	35	1.5	200	125
<b>T4 (Three-phase 380V, 50/60Hz)</b>				
CDI-E180G0R75T4B	2.5	1.0	10	10
CDI-E180G1R5T4B	2.5	1.0	16	10
CDI-E180G2R2T4B	2.5	1.0	16	10
CDI-E180G3R7/P5R5T4B	4.0	1.0	25	16
CDI-E180G5R5MT4B	4.0	1.0	32	25
CDI-E180G5R5/P7R5T4B	4.0	1.0	32	25
CDI-E180G7R5/P011T4B	4.0	1.0	40	32
CDI-E180G011MT4B	4.0	1.0	63	40
CDI-E180G011/P015T4BL	4.0	1.0	63	40
CDI-E180G015/P018.5T4BL	6.0	1.0	63	40
CDI-E180G018.5/P022T4	6.0	1.5	100	63
CDI-E180G022/P030T4	10	1.5	100	63
CDI-E180G030/P037T4	16	1.5	125	100
CDI-E180G037/P045T4	16	1.5	160	100
CDI-E180G045/P055T4	25	1.5	200	125
CDI-E180G055/P075T4	35	1.5	200	125
CDI-E180G075/P093T4	50	1.5	250	160
CDI-E180G093/P110T4	70	1.5	250	160

Chapter 3 Installation and Connection of Frequency inverter

Type of Frequency inverter	Main Circuit Wire Gage (mm <sup>2</sup> )	Control Circuit Wire Gage (mm <sup>2</sup> )	Use-free air breaker MCCB(A)	Electromagnetic contactor MC(A)
CDI-E180G110/P132T4	120	1.5	350	350
CDI-E180G132/P160T4	150	1.5	400	400
CDI-E180G160/P185T4	185	1.5	500	400
CDI-E180G185/P2004	185	1.5	500	400
CDI-E180G200/P220T4L	300	1.5	600	600
CDI-E180G220T4L	300	1.5	600	600
CDI-E180G250/P280T4L	370	1.5	800	600
CDI-E180G280/P315T4L	370	1.5	800	800
CDI-E180G315/P355T4L	450	1.5	800	800
CDI-E180G355/P375T4L	450	1.5	800	800
CDI-E180G375T4L	600	1.5	1000	800
CDI-E180P400T4L	600	1.5	1000	1000
CDI-E180G400T4L	600	1.5	1000	1000
CDI-E180P500T4L	600	1.5	1600	1000
CDI-E180G500T4L	600	1.5	1600	1000
CDI-E180G630T4L	600	1.5	1600	1600
<b>T6 (Three-phase 690V, 50/60Hz)</b>				
CDI-E180G022/P030T6	4.0	1.0	63	40
CDI-E180G030/P037T6	6.0	1.0	63	40
CDI-E180G037/P045T6	6.0	1.5	100	63
CDI-E180G045/P055T6	10	1.5	100	63
CDI-E180G055/P075T6	16	1.5	125	100
CDI-E180G075/P093T6	25	1.5	200	125
CDI-E180G093/P110T6	35	1.5	200	160
CDI-E180G110/P132T6	50	1.5	250	200
CDI-E180G132/P160T6L	50	1.5	250	200
CDI-E180G160/P185T6L	70	1.5	300	250
CDI-E180G185/P220T6L	120	1.5	350	350
CDI-E180G220/P250T6L	150	1.5	400	400
CDI-E180G250/P280T6L	150	1.5	400	400
CDI-E180G280/P315T6L	185	1.5	500	400
CDI-E180G315/P355T6L	300	1.5	600	500
CDI-E180G355/P400T6L	300	1.5	600	600
CDI-E180G400T6L	300	1.5	600	600
CDI-E180P500T6L	370	1.5	800	600
CDI-E180G500T6L	450	1.5	1000	800
CDI-E180P600T6L	450	1.5	1000	800
CDI-E180G600T6L	450	1.5	500	800
CDI-E180P700T6L	600	1.5	500	1000
CDI-E180G700T6L	600	1.5	600	1000

### 3.4 Connection of control circuit

#### 3.4.1 Arrangement and connection of controlling circuit terminals

##### (1) E100 Series

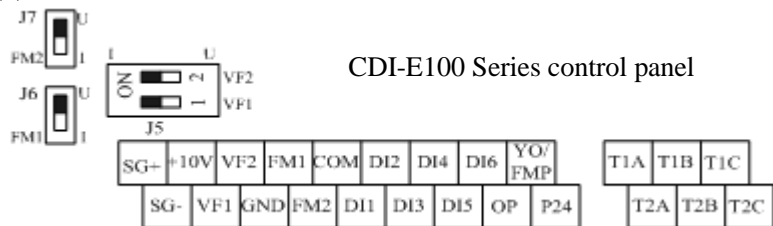

The wiring diagrams of E100 Main Circuit and Control Circuit are as below: (not connecting to L3 for Model S2)

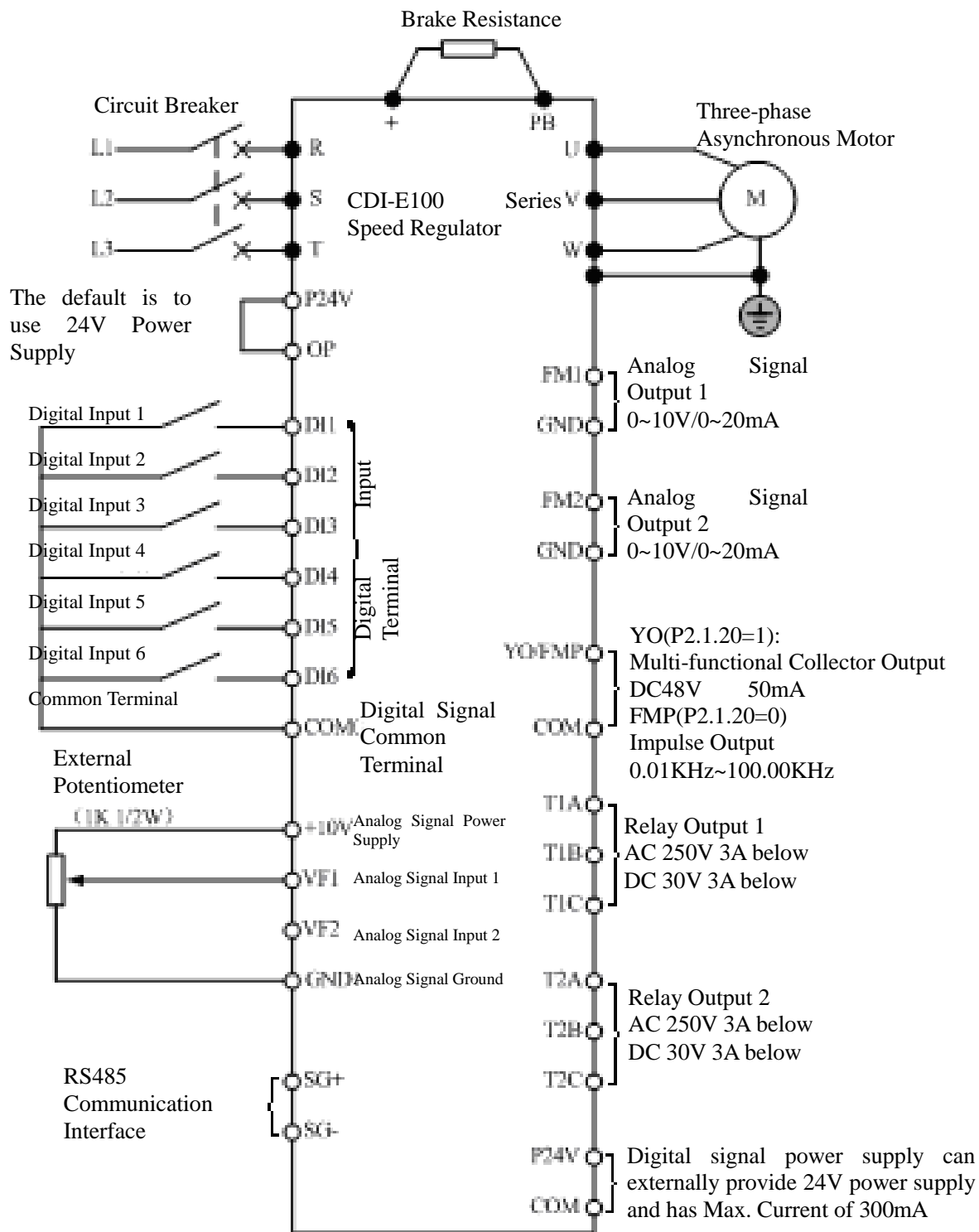

(2) E102 Series

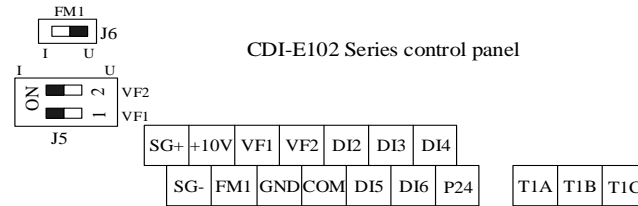

The wiring diagrams or E102 Main Circuit and Control Circuit are as below: (not connecting to L3 for Model S2)

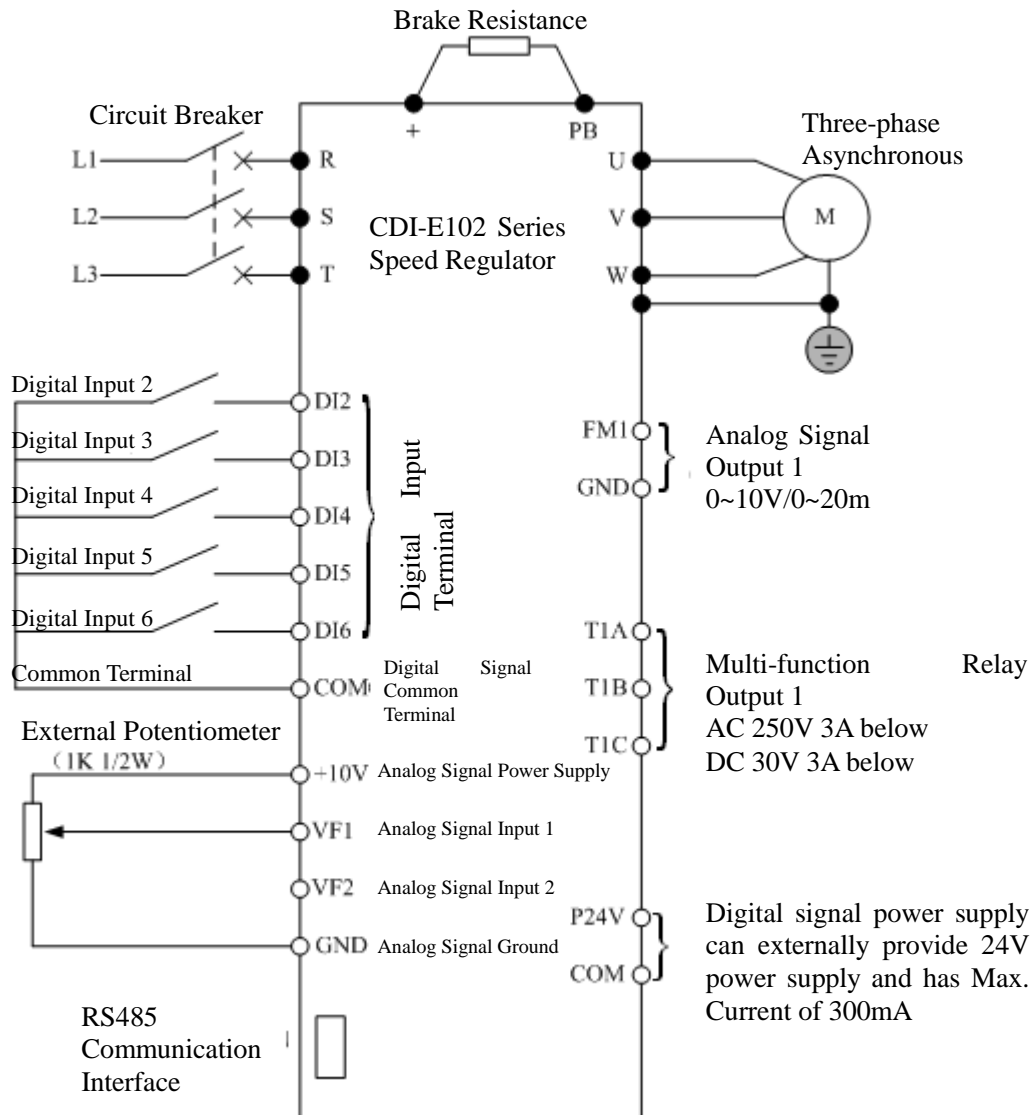

(3) E180 Series

CDI-E180 control panel

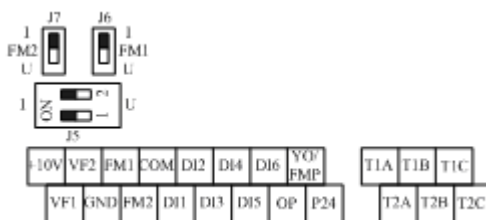

The wiring diagrams or E 180 Main Circuit and Control Circuit are as below:

(standard configuration for 15 kW and below)  
 (option configuration for 18.5 ~ 30 kW and below)

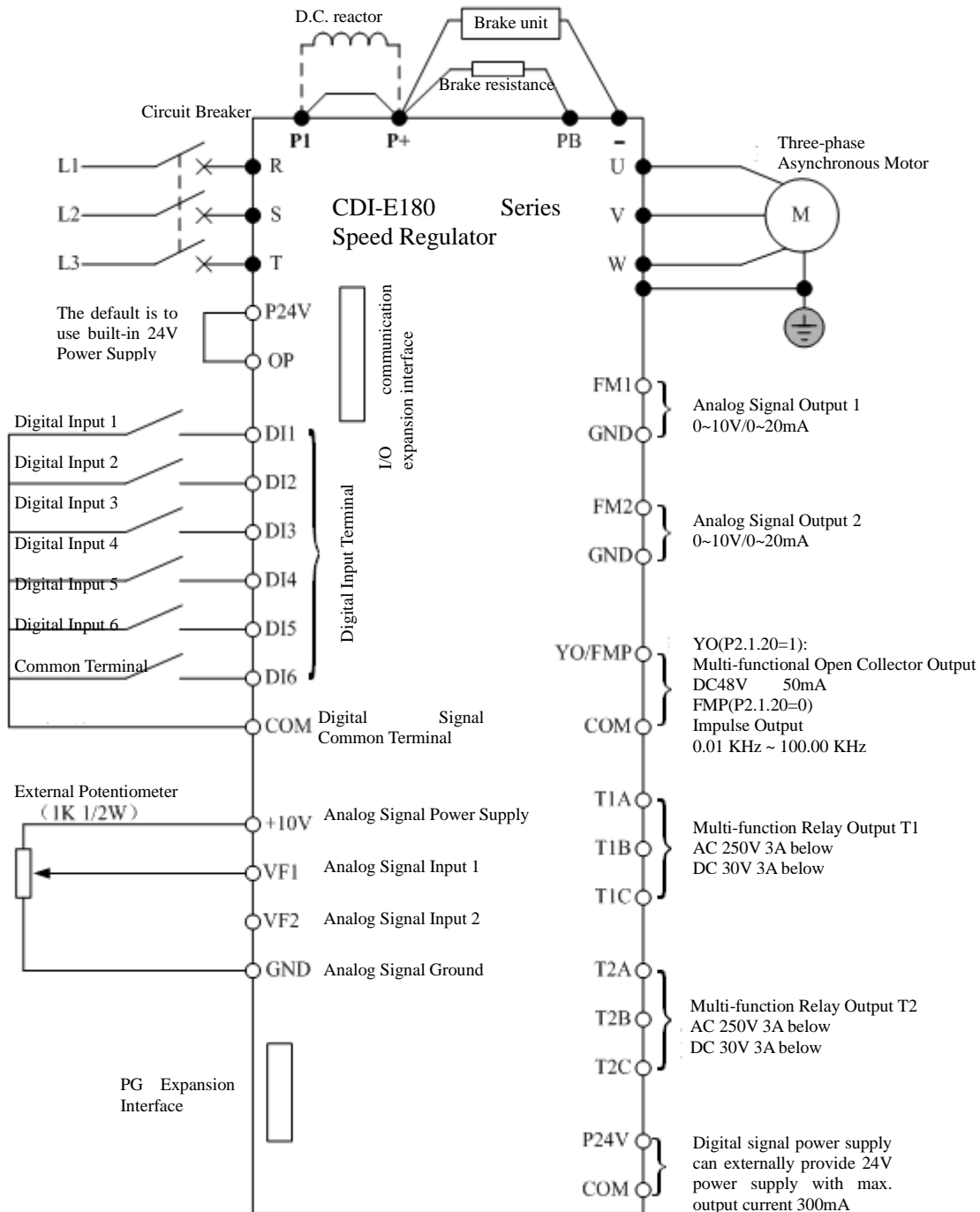

## 3.4.2 Function of control circuit terminal

Following sheet summarize function of control circuit terminal, which is connected according to function respectively.

Category	Terminal	Name of Terminal	Description of Function	
Digital Input Terminal	OP	External Power Input	Take P24V short circuit by factory default. When adopting external power to drive the digital input terminal, disconnect OP and P24V and connect with external power	
	DI1-OP(COM)	Digital Input 1	Terminals are equipped on E Series Control Panel, in which Terminal D16 can be used for high-speed Impulse Input and has maximum input frequency of 100kHz. Specific function refers to the description for use of Function Code P2.0.00~P2.0.05. <b>Note: Terminal DI1 is not available on E102 Series.</b>	
	DI2-OP(COM)	Digital Input 2		
	DI3-OP(COM)	Digital Input 3		
	DI4-OP(COM)	Digital Input 4		
	DI5-OP(COM)	Digital Input 5		
	DI6-OP(COM)	Digital Input 6		
	DI7-COM	Digital Input 7	Refer to the terminals on CDI-E180 Series I/O expansion card, and such terminals are not available on E100 and E102 Series. Specific function refers to the description for use of Function Code P2.0.06 and P2.0.09 <b>Note: Only internal power supply is applicable</b>	
	DI8-COM	Digital Input 8		
	DI9-COM	Digital Input 9		
DI10-COM	Digital Input 10			
Multi-functional Output Terminal	T1A	Multi-functional Relay T1 Output	TA-TB is normally open TA-TC is normally closed Drive Capability: AC250V 3A below DC30V 3A below <b>Note: Terminal T2 is not available on E102 Series</b>	
	T1B			
	T1C			
	T2A	Multi-functional Relay T2 Output		
	T2B			
	T2C			
	YO1	Multi-functional Open Collector Output 1		Refer to the terminal on E180 Series I/O expansion card, and such terminals are not available on E100 and E102 Series. Specific function refers to the description for use of Function Code P2.0.28 and P2.0.31 Drive Capability: DC48V 50mA below
	CME			
YO2	Multi-functional Open Collector Output 2			
CME				
Analog Input Signal	10V	10V Power Output	Provide DC 10V supply voltage externally and generally adopt it as working power for external potentiometer Drive Capability: 50mA below	
	GND			
	VF1-GND	Analog Input Terminal 1	Be used for receiving external analog signal input, 0V~10V voltage signal or 0/4mA~20mA current signal	
	VF2-GND	Analog Input Terminal 2		
	VF3-GND	Analog Input Terminal 3	Refer to the terminals on E180 Series I/O expansion card and are controlled by J9 on expansion card. They can not be used together with keyboard potentiometer. E100 & E102 Series don't have these terminals. Only voltage signal: 0V~10V, the function is same as potentiometer.	

Category	Terminal	Name of Terminal	Description of Function
Analog Output Signal	FM1-GND	Analog Output Terminal 1	Output 0~10V voltage or 0~20mA current <b>Note: Terminal FM2 is not available on E102 Series</b>
	FM2-GND	Analog Output Terminal 2	
Dual-purpose Terminal	YO/FMP	Multi-functional Open Collector Output and Common Terminal for Impulse Output	When P2.1.20=1, this terminal is used as multi-functional collector output YO Drive Capability: DC48V 50mA below
	COM	<b>Note: Such terminal is not available on E102 Series</b>	When P2.1.20=0, this terminal is used as Impulse Output FMP Impulse frequency: 0.01kHz~100.00kHz
24V Power	COM	24V Power Output	Provide DC 24V supply voltage externally and generally adopt it digital input terminal or as working power for external low-voltage equipments Drive Capability: Max. Output Current 300mA
	P24		
Communication Terminal	SG+	Positive Signal Terminal of RS485 Communication	E100 Series directly has two terminals on control panel. E102 and E180 Series are not equipped with such two terminals on control panel, but on communication expansion card
	SG-	Negative Signal Terminal of RS485 Communication	

### 3.4.3 Wiring Instruction for Control Circuit

To avoid interfere, please distribute control loop apart from main loop and heavy current loop (relay contact, 220V loop), the Shielded Twisted Cable or Shielded Twisted Pair should be used in wiring the control circuit; the shielding sheath should be connected to terminal PE of the frequency inverter and the wire distance should be less than 50 meters to prevent misoperation from interference.

#### 1. Description for Circuit Wiring of Analog Input Terminal

J5-1 controls VF1 channel to select voltage/current signal input. When current signal input is selected, switch of J5 is at I side; when voltage signal input is selected, switch of J5 is at U side.

J5-2 controls VF2 channel to select voltage/current signal input. When current signal input is selected, switch of J5 is at I side; when voltage signal input is selected, switch of J5 is at U side.

#### 2. Description for Circuit Wiring of Analog Output Terminal

J6 controls FM1 channel to select voltage/current signal input. When current signal input is selected, switch of J6 is at I side; when voltage signal input is selected, switch of J6 is at U side.

J7 controls FM1 channel to select voltage/current signal input. When current signal input is selected, switch of J7 is at I side; when voltage signal input is selected, switch of J7 is at U side.

#### 3. Description for Circuit Wiring of Digital Input Terminal

Shielded Cable or Shielded Twisted Pair should be used for digital input at the maximum possibility to avoid interference from external signal and the wire distance should be less than 50 meters.

##### (1) E100 and E180 Series

The wiring diagram on digital input circuit control panel is as below

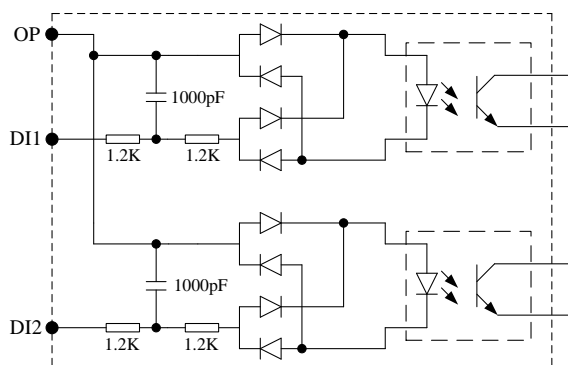

● Dry Contact Common Cathode Wiring Method

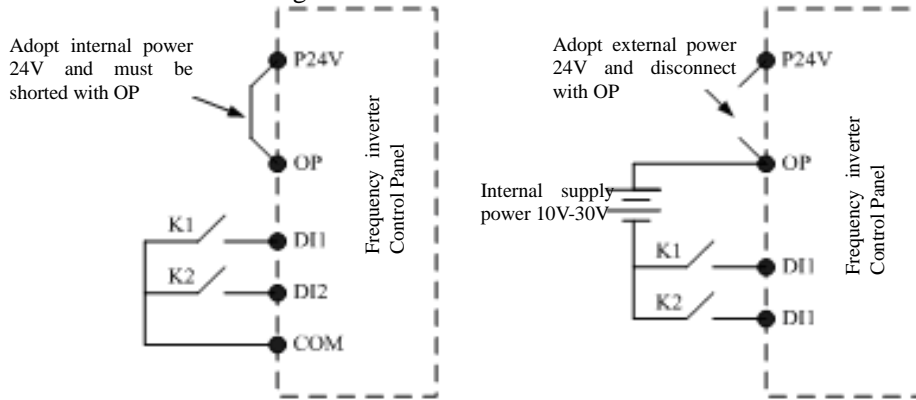

● Dry Contact Common Anode Wiring Method

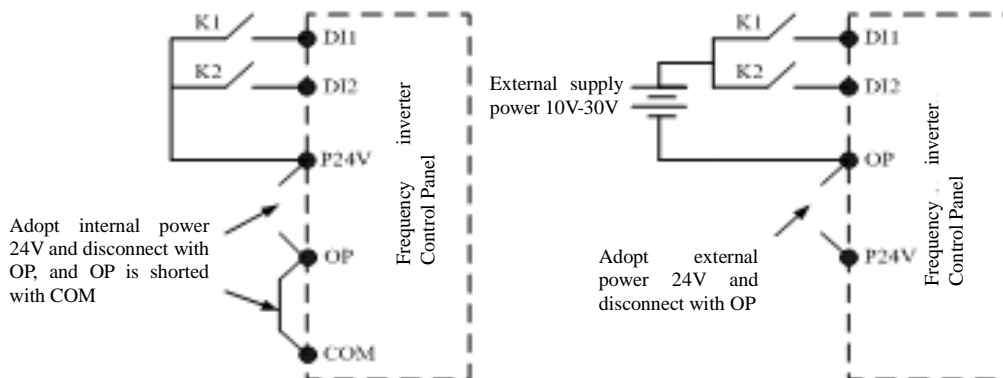

● Leaking-type Wiring Method

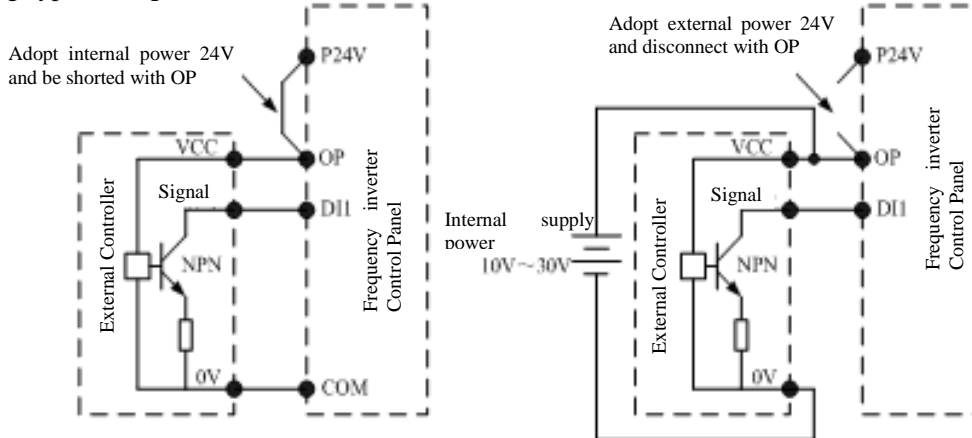

● Source-type Wiring Method

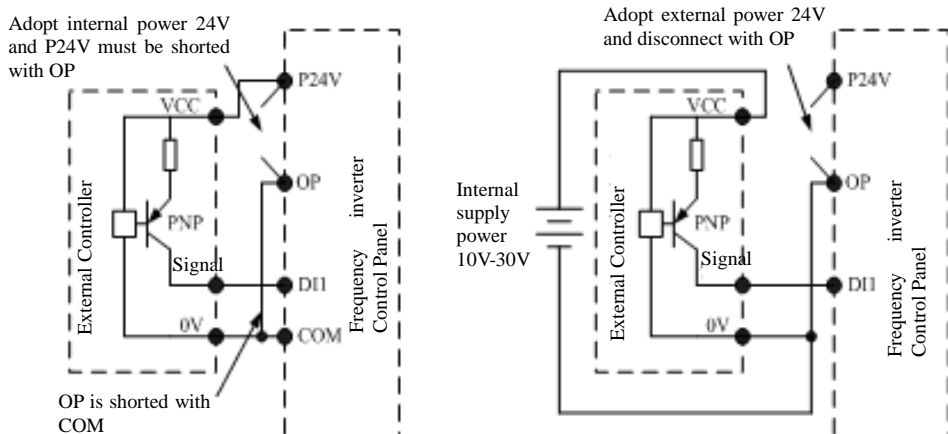

(2) E102 Series

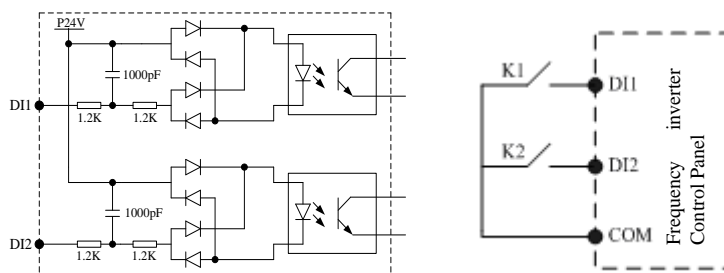

The wiring diagram on digital input circuit control panel is as below

4. Description for Circuit Wiring of Multi-functional Output Terminal

● AC Circuit

The AC Circuit can only be used for multi-functional relay output terminal. If it is to drive inductive load (e.g. electromagnetic relay and contactor), the surge voltage absorber shall be installed, e.g. RC Absorber (the leakage current shall be less than the holding current of controlled contactor or relay), as shown in the figure below:

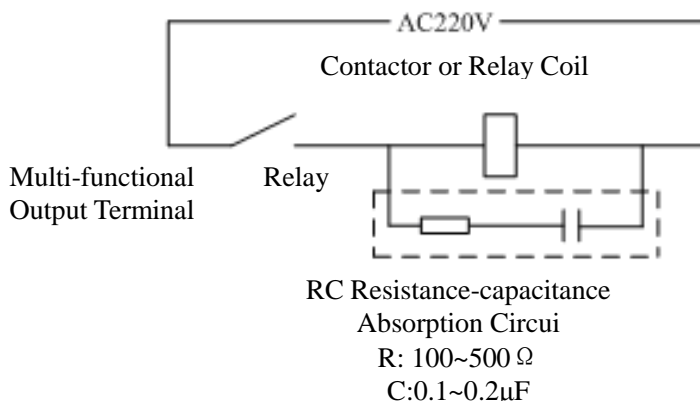

● DC Circuit

The DC Circuit can not only be used for multi-functional open collector output terminal (attention for wiring polarity), but for multi-functional relay output terminal. If it is to drive DC Magnetic Circuit, the fly-wheel diode (attention for polarity), as shown in the figure below:

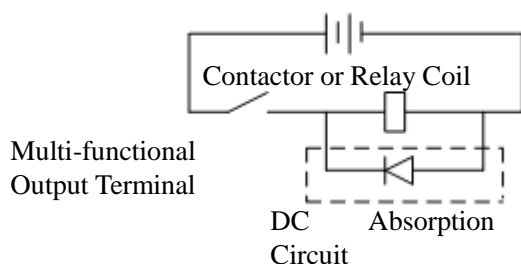

5. Description for Circuit Wiring of Impulse Output Terminal (E102 invalid)

When the function code is P2.1.20=0, Terminal YO/FMP is used as Impulse Output Terminal. The default circuit is passive impulse output. If the active impulse is required to output, the users need to match the power (internal power or external power of the frequency inverter available) and pull-up resistor. **Note: allowable limit of internal circuit: DC48V 50mA below**

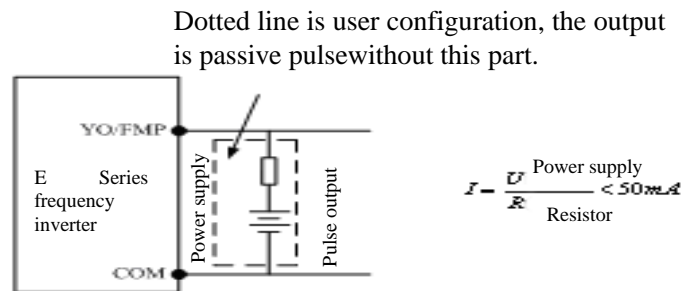

3.5 Grounding

1. Grounding resistance value:

200V level: 100Ω or value below it

400V level: 10Ω or value below it

660V level: 5Ω or value below it

2. Prevent E frequency inverter, welding machine, motor or other huge current electrical equipment from earthing. Ensure all earthing lines and wires of huge current electrical equipment are separately laid inside the pipe.

3. Please use approved grounding wire of which length should be as shorter as possible.

4. When several E frequency inverters are used in parallel, please ground the device as shown by Figure (a), instead of Figure (c) which may form a loop.

5. Grounding of frequency inverters and motor can be connected as per Figure (d).

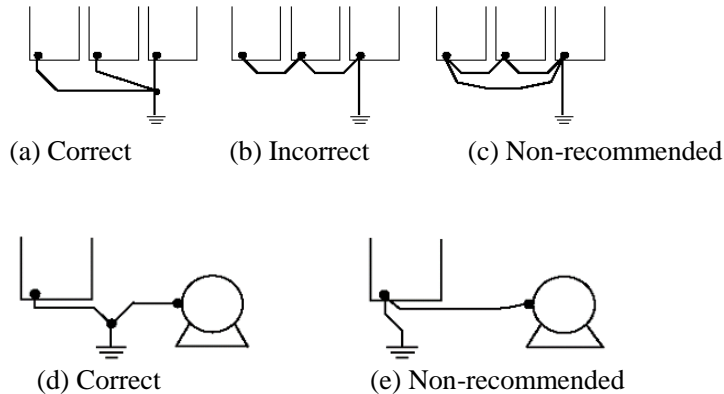

6. Connection inspection:

Please perform following items if installation and connection are completed.

If connection is correct.

If stub or screw remains in device.

If screws are fastened firmly.

If bare conductor on terminal contacts with other terminals.



## Chapter 4 Keyboard Operation and Running

### 4.1 Option of operating mode

E Series Frequency inverters provide 3 control modes, including keyboard operation, terminal operation and communication operation. The user can select relative control mode as per onsite circumstances and working requirements. See 7.1 for specific selection.

### 4.2 Test run and inspection

#### 4.2.1 Precautions and inspection before test run

 Dangerous	<ol style="list-style-type: none"> <li>1. Input power can be connected only after front lid is installed. Do not remove external lid when powered, otherwise it may lead to electric shock.</li> <li>2. Do not get close to the frequency inverter or the load when selecting re-start because it may suddenly restart after being stopped just a moment ago. (Even though the frequency inverter can restart, its mechanical system can safeguard individual safety) otherwise it may cause hurt to human body.</li> <li>3. Because function setting can defunction the stop button, it is required to install an independent emergency button; otherwise it may cause hurt to human body.</li> </ol>
 Attention	<ol style="list-style-type: none"> <li>1. Do not touch the radiator or resistor because its temperature is very high; otherwise it may lead to burn.</li> <li>2. Because low speed can be easily changed to high speed, it is required to confirm safe working scope of the motor and mechanical equipment before operation; otherwise it may cause hurt to human body and damage to equipment.</li> <li>3. If necessary, separately install a contracting brake; otherwise it may cause hurt to human body.</li> <li>4. Do not change connection during operation; otherwise the equipment or frequency inverter may be damaged.</li> </ol>

For ensuring operation safety, please relieve mechanical connector before first operation to separate motor from mechanical equipment and prevent from dangerous. Please perform following inspection before test run:

- A. If connection between lead and terminal is correct.
- B. If lead thum cause short circuit.
- C. If screw terminal is fastened firmly.
- D. If motor is installed firmly.

#### 4.2.2 Test run

After preparation, connect to power supply and inspect if frequency frequency inverter works normally.

After connected to power supply, indicator of number keyboard is luminous.

Please cut off power supply immediately if any problem abovementioned occurs.

#### 4.2.3 Operating inspection

Please verify following items during operation:

- A. If motor rotates smoothly.
- B. If rotation direction of motor is correct.
- C. If abnormal vibration or noise occurs accompanying with operation of motor.
- D. If acceleration and deceleration are smooth.
- E. If current match with load value.
- F. If LED state indicator and number keyboard displays correctly.

4.3 Operating method of keyboard.

4.3.1 Keys on keyboard and their functions

(1) E100 and E102 Series LED Keyboard

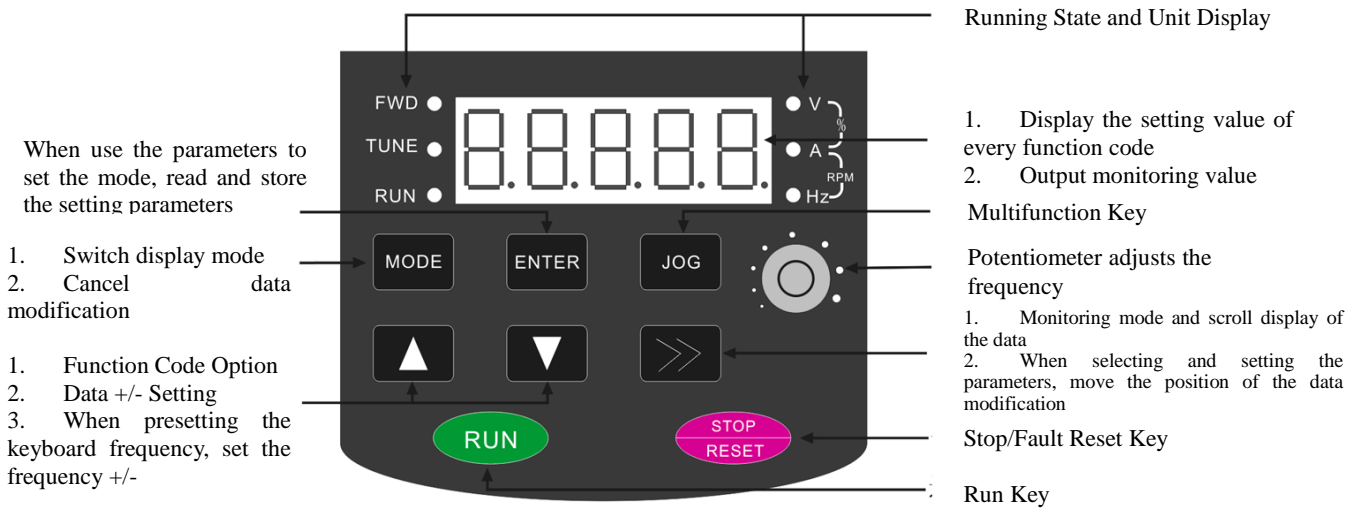

Installation Dimension of Operation Keyboard      Function of Indicator

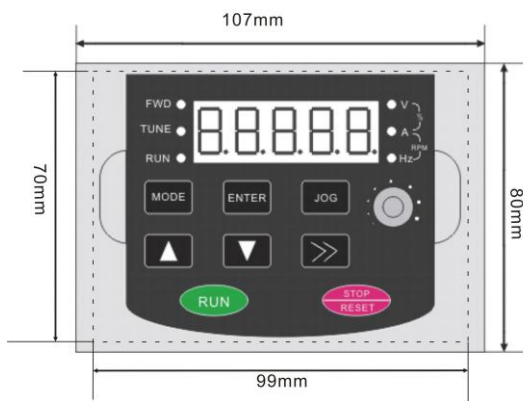

NO	Name	Description of Function
1	FWD	When rotating in the forward direction, the indicator lights up, but when rotating in the backward direction, the indicator doesn't work,
2	TUNE	When the parameter identification function operates, the light flickers. The light is normally on at torque control mode
3	RUN	The frequency inverter lights up under running state
4	V	Indicate voltage value
5	A	Indicate current value
6	Hz	Indicate frequency
7	V-%-A	Indicate percentage
8	A-RPM -Hz	Indicate rotating speed

Installation dimension of Keyboard Booth:99\*70mm

Outer dimension of Keyboard Booth: 107\*80mm

(2) E180 series keypad

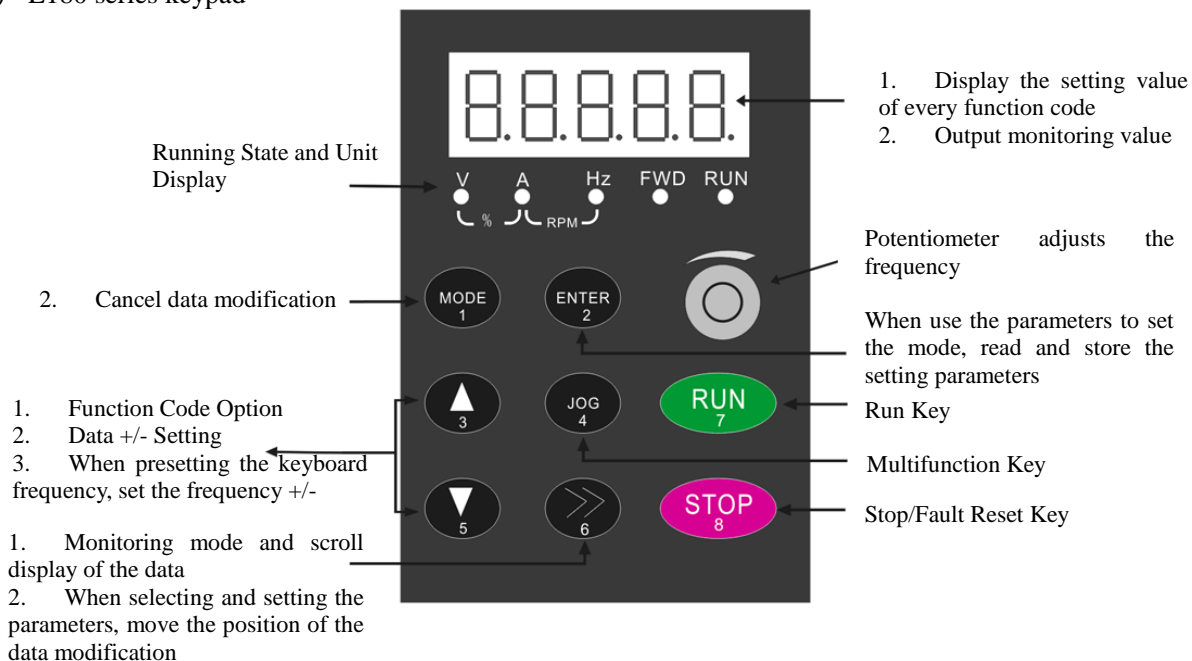

**Installation Dimension of Operation Keyboard      Function of Indicator**



NO	Name	Description of Function
1	FWD	When rotating in the forward direction, the indicator lights up, but when rotating in the backward direction, the indicator doesn't work,
2	RUN	The frequency inverter lights up under running state
3	V	Indicate voltage value
4	A	Indicate current value
5	Hz	Indicate frequency
6	V-%-A	Indicate percentage
7	A-RPM-Hz	Indicate rotating speed

Installation dimension of Keyboard Booth: 97\*59mm

Outer dimension of Keyboard Booth: 105\*67mm

**Note: E180 series LED keypad is equipped by default on the E180 series inverter type 1, 2 and 3.**

(3) E180 series primary keypad

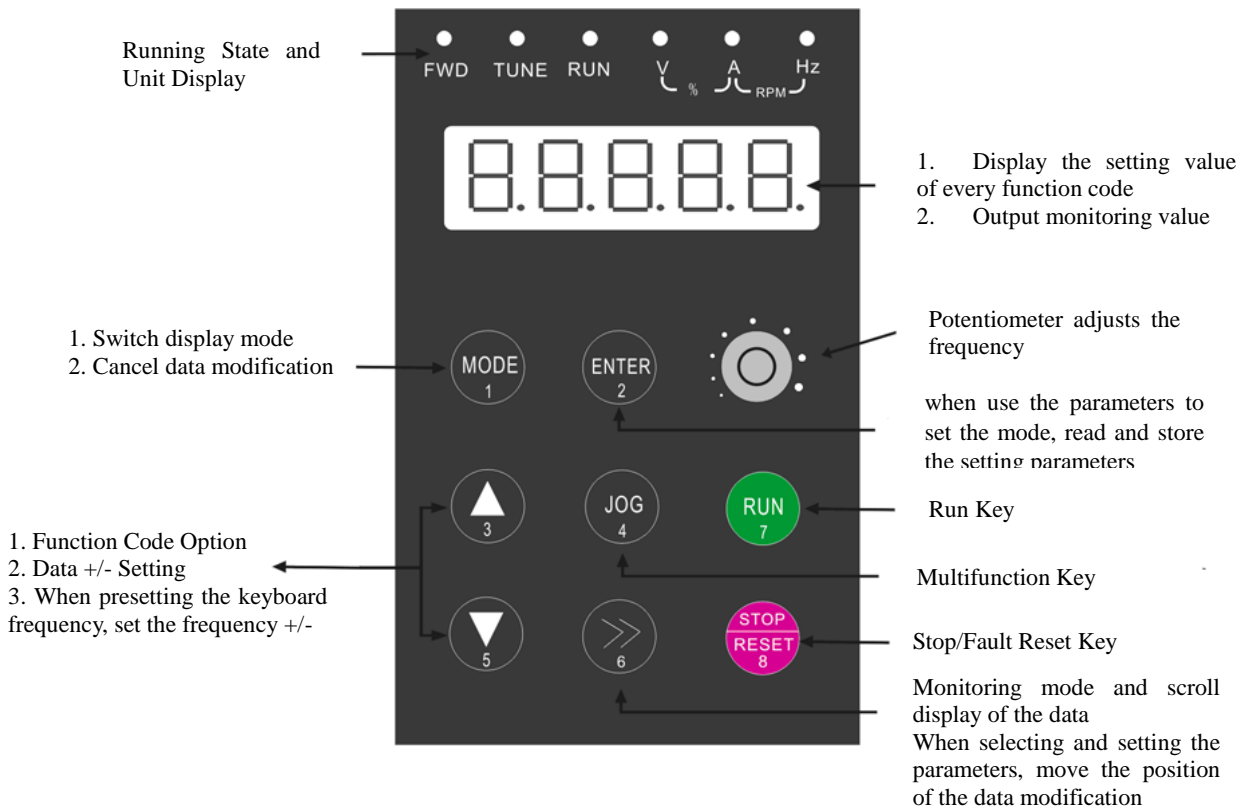

**Installation Dimension of Operation Keyboard** **Function of Indicator**



Installation dimension of Keyboard Booth: 136\*72mm

NO	Name	Description of Function
1	FWD	When rotating in the forward direction, the indicator lights up, but when rotating in the backward direction, the indicator doesn't work,
2	TUNE	When the parameter identification function operates, the light flickers. The light is normally on at torque control mode
3	RUN	The frequency inverter lights up under running state
4	V	Indicate voltage value
5	A	Indicate current value
6	Hz	Indicate frequency
7	V-%-A	Indicate percentage
8	A-RPM-Hz	Indicate rotating speed

Outer dimension of Keyboard Booth: 142\*78mm

**Note: E180 series LED primary keypad is equipped by default on the E100 and E102 series inverter type 5 and above ,and default on the E180 series inverter type 4 and above.**

(4) E180 series LCD keypad

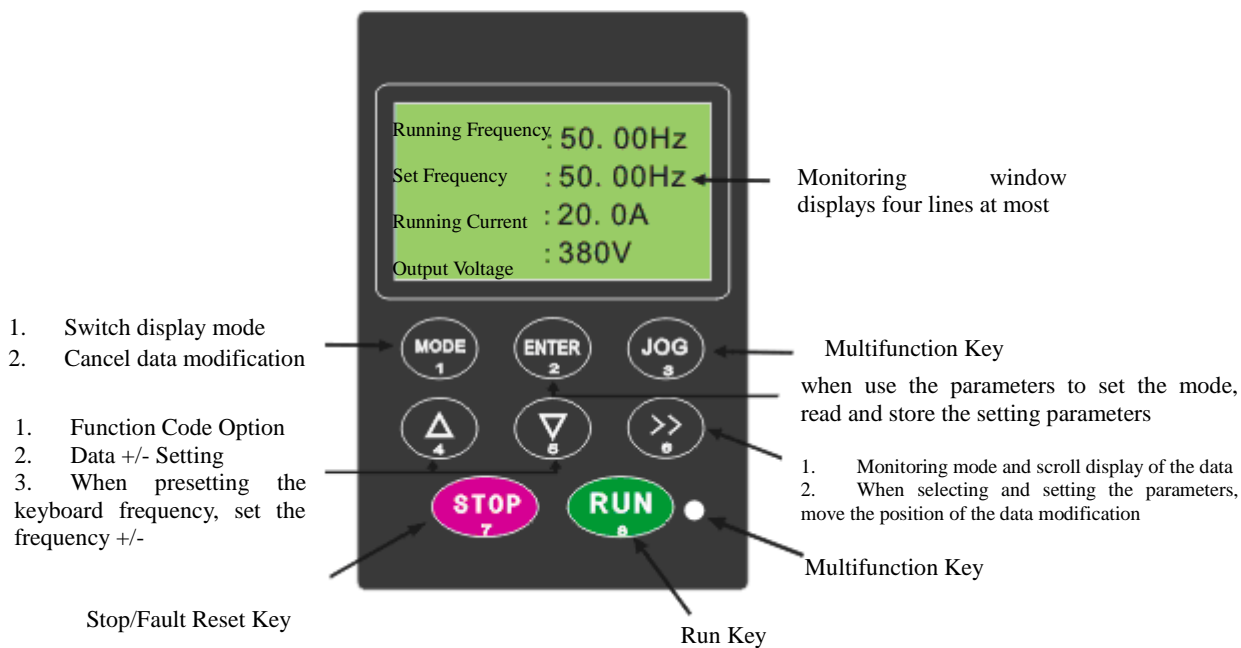

Installation dimension of Keyboard Booth:97\*59mm      Outer dimesion of Keyboard Booth: 105\*67mm

Statement: the maximum four lines can be simultaneously displayed under surveillance screen. Specific displayed contents are determined by Function Code P5.0.06~P5.0.13 (Details refer to the Description for P5.0.06~P5.0.13). Press Key >> and select one line. If the parameter attribute is writable, press Key ENTER and directly enter into parameter modification page, after completing the modification, press ENTER and return to surveillance screen.

**Note: E180 series LCD keypad is optional on the E180 series inverter type 1, 2 and 3.**

(5) E180 series primary keypad

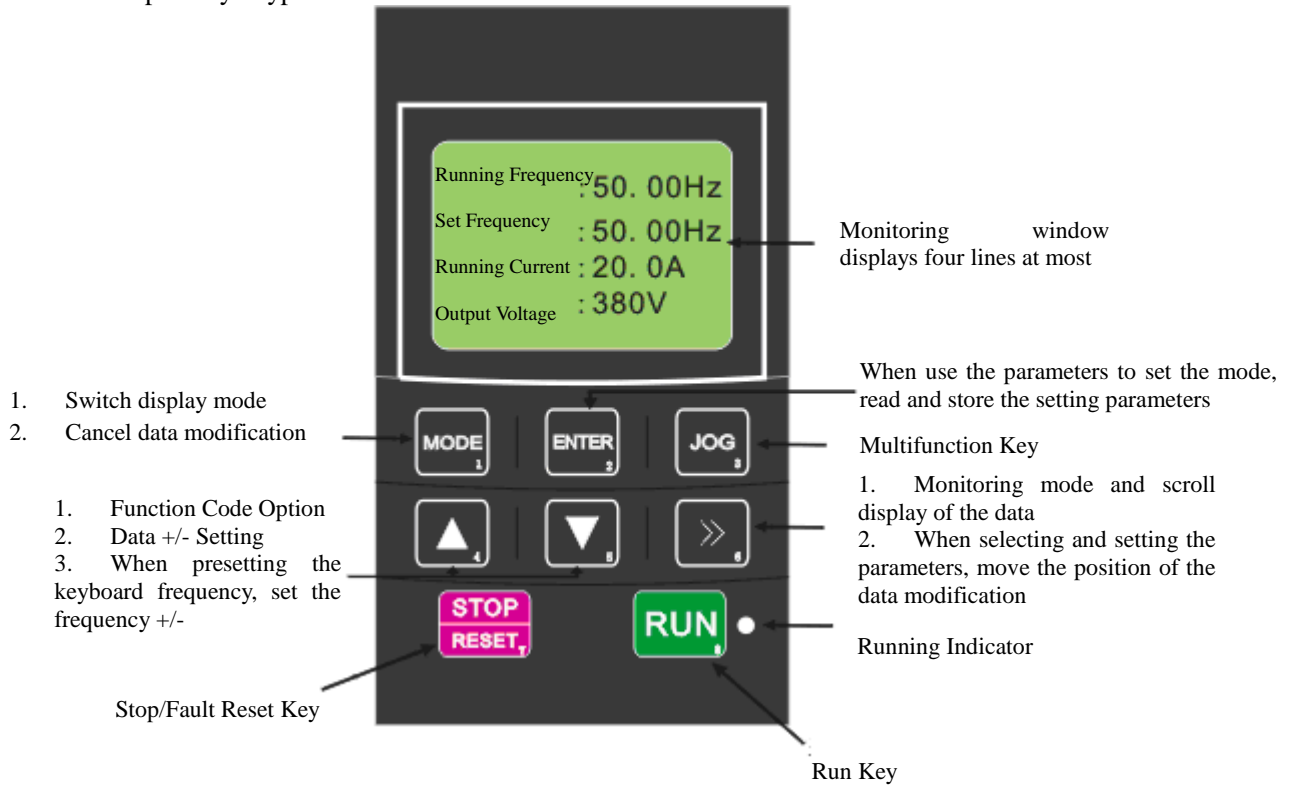

Installation dimension of Keyboard Booth: 136\*72mm      Outer dimension of Keyboard Booth: 142\*78mm

**Note: E180 series LCD primary keypad is optional on the E180 series inverter type 4 and above.**

### 4.3.2 Data Monitoring Mode

#### 1. Cycle Monitor Mode

In Monitor Mode, press Key >> per time and change one display item to check current state information of the frequency inverter

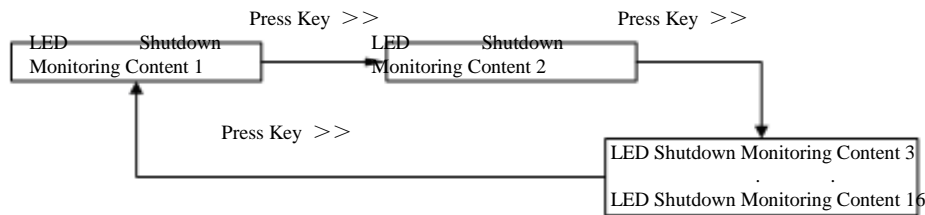

In shut-down state, the contents for 16 downtimes can be cycled at most, and specific contents shown in the cycle shall be determined by Function Code P5.0.05 (Details refer to the Description for P5.0.05)

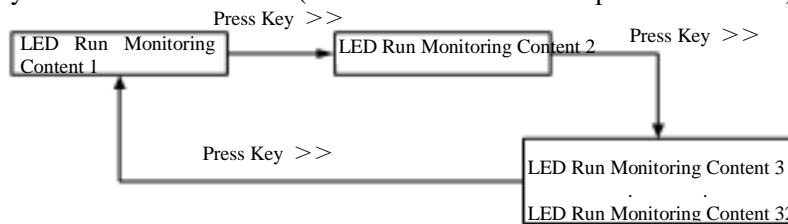

Under running state, the contents for 32 running surveillance can be cycled at most, and specific contents shown in the cycle shall be determined by Function Code P5.0.02 and P5.0.03 (Details refer to the Description for P5.0.02 and P5.0.03).

#### 2. Fault/Alarm Monitor Mode

- A. Under state of running monitor, the unit should display information relating to fault and warning if fault and alarm occurs.
- B. Reset fault by press STOP/RESET if fault disappears.
- C. Please cut off power supply and reset the unit if serious fault occurs.
- D. Keyboard should display fault code continuously until fault is eliminated (refer to Chapter IX).

### 4.3.3 Use of Multi- Function Key JOG

Upon the demand of the users, set Function Code P5.0.00 and realize the definition of the users to Function Key JOG, and the Key JOG can choose dead and forward rotation jogging running, reverse rotation jogging running and switch between forward rotation and reverse rotation, in which forward rotation jogging running and reverse rotation jogging running are valid under any running control, and the switch between forward rotation and reverse rotation is only valid under keyboard control mode.

4.3.4 Parameter check and set methods (using digital keyboard)

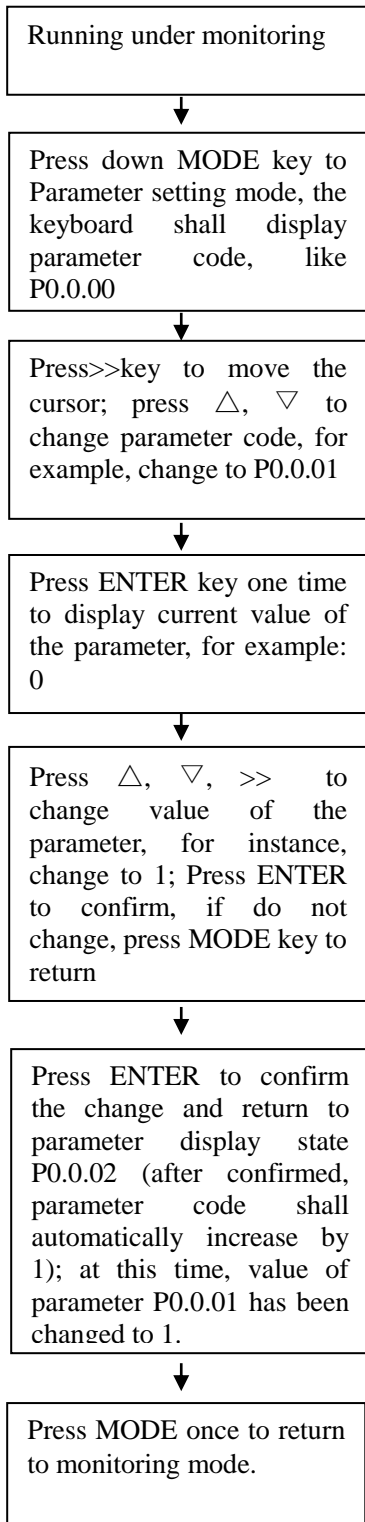

Example: the following is an example to change value of P0.0.10 from 010.0 to 016.1:

1	50.00	Display set frequency 50.00Hz; Press MODE key to enter parameter setting mode
2	P0.0.00	Parameter P0.0.00 appears, at the same time the pointer points to the last digital bit “0” and twinkles. Press >> to select parameter code to set; press Δ, ∇ key to move the data bit.
3	P0.0.10	Press Δ, ∇, >> to change value displayed to P0.0.10, the ENTER
4	010.0	Check whether factory-set, value of the parameter is 010.0; at the same time the pointer points to the last digital bit “0”.
5	016.0	Press Δ, ∇, >> to change value displayed to 016.1, then ENTER.
6	P0.0.12	Data storage writes in 016.0; the parameter displays that the acceleration time is changed to 016.0 from 010.0, and then it is to return to the parameter that displays P0.0.12 at this time
7	P0.0.10	If directly press MODE instead of ENTER is step 5, the keyboard shall return to display P0.0.10, and the data changed is not stored. acceleration times is still 010.0.
8	50.00	Then press MODE again return to running under monitoring mode to display the set frequency.

**Note:** And it is impossible to modify data under following conditions.

- 1.It is impossible to adjust parameter during operation of frequency inverter. (Refer to function sheet)
- 2.Start parameter protection in P5.0.18 (parameter write-in protection)

#### 4.4 Function Code Display Mode

E Series Frequency inverter provides three kinds of Function Code Display Modes: Basic Mode, User Mode and Verification Mode.

- Basic Mode (P0.0.01=0)

In basic mode, the function code has the prefix with 'P'. At this time, the Function Code P5.0.17 determines what parameters of the function codes are specifically displayed. Its ones, tens, hundreds and thousands respectively correspond to each function code group. Refer to the following table for explanation of specific meaning.

Function Code	Setting scope		Explanation
Function parameter displays the Option of P5.0.17	Ones	0	Only display basic parameter group
		1	Display the menus at all levels
	Tens	0	Don't display Group P7
		1	Display Group P7
		2	Reserve
	Hundreds	0	Don't display verification group
		1	Display verification group
	Thousands	0	Don't display code group
1		Display code group	

- User Mode (P0.0.01=1)

Only display customization parameters of user function and use Function Code of Group P7.0 to determine what parameters of the function codes (with maximum quantity is 30) are specifically displayed by the frequency inverter. In user mode, the function code has the prefix with 'U'.

Function Code	Setting scope		Explanation
Function parameter displays the Option of Group P7.0	P7.0.00	U0.0.01	When the parameter of function code is set, it is deemed that this function code is selected as user customization function code. 30 parameters of function codes can be selected and set at most.
	.....	U0.0.00~UX.X.XX (except for group P7 and P8)	
	P7.0.29	U0.0.00~UX.X.XX (except for group P7 and P8)	

- Verification Mode (P0.0.01=2)

Only display the modified parameters (in case of any difference of function code between reference value and factory set value, it is deemed that the parameters are changed), the function code has the prefix with 'C' in verification mode.

## Chapter 5 Tables of Function Parameters

### Description for Tables of Function Parameters

1. Function parameters of E Series Frequency inverter are divided into 9 groups as per the functions. Each group includes several sub-groups and each sub-group includes several function codes, which can be set with different values.

2. P××.×× in function sheet or other section of the manual denotes “××” function code of sort “××”; For example, “P0.0.01” denotes function code 01 of sort P0.0.

3. Content explanation of function sheet:

Column 1 “Function Code”: serial number of function code parameter; Column 2 “Function Name”: full name of function parameter; Column 3 “Setting Scope”: scope of valid set value of function parameters; Column 4 “Factory Setting”: original set value of function parameters when delivered out of the factory; Column 5 “Change Limit”: change property of function parameters (that is, whether change and changing conditions are allowed); Column 6 “Reference Page”: page refers to detailed description of function code parameters.

Modification limit of parameter is explained as below:

“☆”: Denote that the set value of the parameter is modifiable under stop or running state of the frequency inverter;

“★”: Denote that the set value of the parameter is not modifiable under running state of the frequency inverter;

“●”: Denote that the value of the parameter is actual testing value and not modifiable;

“○”: Denote that this parameter is allowed to be modified only at P5.0.18=2

“▲”: Denote that this function in E100 Series is invalid and not allowed to be modified

“△”: Denote that this function in E102 Series is invalid and not allowed to be modified.

### Explanation 1:

E102 Series is a simple version of E100. The hardware of E102 is simplified, so the invalid function on E100 Series is also invalid on E102. But the performance and function (without hardware support is not considered) of E102 are same as E100 Series

### Explanation 2:

Please read the manual carefully while modifying parameter of frequency inverter. And contact our Company for any problem occurs during operation. No data submits to customer modification, violation of it maybe causes serious fault, or significant property loss, of which consequences should be born by User!

## 5.1 P0 Group - Basic Function

Function code	Function name	Setting scope	Factory set value	Modification limit	Reference page
<b>Group P0.0 Basic Group</b>					
P0.0.00	Type of Frequency inverter	1. G Type (constant torque load type) 2. P Type (fans and water pump load type)	Machine type	○	80
P0.0.01	Display Mode	0: Basic Mode (Prefix with 'P') 1: User Mode (Prefix with 'U') 2: Verification Mode (Prefix with 'C')	0	☆	
P0.0.02	Control Mode	0: V/F Control 1: Open-loop Vector Control (SVC) 2: Closed-loop Vector Control (Invalid E100)	0	★	81
P0.0.03	Option of operation control mode	0: Keyboard Control 1: Terminal Control 2: Communication Control	0	☆	
P0.0.04	Option of A Frequency Source	0: Keyboard Reference (No Power-off Memory) 1: Keyboard Reference (Power-off Memory) 2: Keyboard Potentiometer Reference 3: External Terminal VF1 Reference 4: External Terminal VF2 Reference 5: PULS Reference (DI6) 6: Multiplex Directive Reference 7: Simple PLC Reference 8: PID Control Reference 9: Communication Reference 10: Operation Result 1 11: Operation Result 2 12: Operation Result 3 13: Operation Result 4	02	★	82
P0.0.05	Keyboard Frequency Reference	000.00~ maximum frequency	050.00	☆	83
P0.0.06	Running Direction	0: Default Direction 1: Negation of Direction 2: Determined by multi-function input terminal	0	☆	84
P0.0.07	Maximum frequency	050.00Hz~320.00Hz	050.00	★	
P0.0.08	Upper frequency	Lower frequency ~ highest frequency	050.00	★	
P0.0.09	Lower frequency	000.00~ Upper frequency	000.00	☆	85
P0.0.10	Lower frequency operation mode	0: Running at lower limit frequency 1: Stop 2: Zero-speed Running	0	☆	
P0.0.11	Acceleration Time	0000.0~6500.0s	Machine type	☆	
P0.0.12	Deceleration Time	0000.0~6500.0s	Machine type	☆	

Function code	Function name	Setting scope	Factory value	set	Modification limit	Reference page
P0.0.13	Type of Motor	0: Common Motor 1: Variable Frequency Motor 2: Synchronous Motor (Valid E100)	0		★	86
P0.0.14	Motor rated power	0000.1kW ~ 1000.0kW	Machine type		★	
P0.0.15	Motor rated frequency	000.01Hz ~ Highest frequency	050.00		★	
P0.0.16	Motor rated voltage	0001V ~ 2000V	Machine type		★	
P0.0.17	Motor rated current	000.01A ~ 655.35A (power inverter < 75kW) 0000.1A ~ 6553.5A (power inverter ≥ 75kW)	Machine		★	
P0.0.18	Motor Rated Rotating Speed	00001rpm ~ 65535rpm	Machine		★	
P0.0.19	Stator resistance of asynchronous motor	00.001 Ω ~ 65.535 Ω (power inverter ≥ 75kW) 0.0001 Ω ~ 6.5535 Ω (power inverter ≥ 75kW)	Machine		★	
P0.0.20	Rotor resistance of asynchronous motor	00.001 Ω ~ 65.535 Ω (power inverter ≥ 75kW) 0.0001 Ω ~ 6.5535 Ω (power inverter ≥ 75kW)	Machine		★	
P0.0.21	Leakage inductance of asynchronous motor	000.01mH ~ 655.35mH (power inverter ≥ 75kW) 00.001mH ~ 65.535mH (power inverter ≥ 75kW)	Machine		★	
P0.0.22	Mutual inductance of asynchronous motor	0000.1mH ~ 6553.5mH (power inverter ≥ 75kW) 000.01mH ~ 655.35mH (power inverter ≥ 75kW)	Machine		★	
P0.0.23	Non-load current of asynchronous motor	000.01A ~ Motor rated current (power inverter ≥ 75kW) 0000.1A ~ Motor rated current (power inverter ≥ 75kW)	Machine		★	87
P0.0.24	Parameter Identification Control	00: No action 01: Static identification 02: Complete identification 11: Synchronous motor on-load identification (Invalid E100) 12: Synchronous motor non-load identification (Invalid E100)	00		★	

Function code	Function name	Setting scope	Factory set value	Modification limit	Reference page
<b>P0.1 Group: Expansion Group</b>					
P0.1.00	Option of Frequency Source	0: Frequency Source A 1: Frequency Source B 2: Frequency Source A+B 3: Frequency Source A-B 4: Max. Value of A & B 5: Min. Value of A & B 6: Standby Frequency Source 1 7: Standby Frequency Source 2 8: Switch of Terminal among the above 8 kinds	0	☆	88
P0.1.01	Option of Frequency Source B	0: Keyboard Reference (No Power-off Memory) 1: Keyboard Reference (Power-off Memory) 2: Keyboard Potentiometer Reference 3: External Terminal VF1 Reference 4: External Terminal VF2 Reference 5: PULS Reference (DI6) 6: Multiplex Directive Reference 7: Simple PLC Reference 8: PID Control Reference 9: Communication Reference 10: Operation Result 1 11: Operation Result 2 12: Operation Result 3 13: Operation Result 4	00	★	89
P0.1.02	Adjustment Volume of: Frequency Source B at superposition	000% ~ 150%	100%	☆	
P0.1.03	Upper Limit Frequency Source	0: Digital Reference (P0.0.08) 1: External Terminal VF1 Reference 2: External Terminal VF2 Reference 3: Multiplex Directive Reference 4: PULS Reference (DI6) 5: Communication Reference 6: Operation Result 1 7: Operation Result 2 8: Operation Result 3 9: Operation Result 4	0	★	
P0.1.04	Upper Limit Frequency Offset	000.00~Highest Frequency	000.00	☆	
P0.1.05	Keyboard Reference frequency Shut-down Memory Selection	0: No Memory 1: Memory	0	☆	91
P0.1.06	Keyboard Reference frequency Action Benchmark at running	0: Running Frequency 1: Reference frequency	0	★	
P0.1.07	Benchmark frequency of accelerating and Deceleration time	0: Highest Frequency 1: Reference frequency 2: 100Hz	0	★	92

Function code	Function name	Setting scope	Factory set value	Modification limit	Reference page
P0.1.08	Jogging running frequency	000.00~Highest Frequency	002.00	☆	92
P0.1.09	Jogging Acceleration time	0000.0s~6500.0s	0020.0	☆	
P0.1.10	Jogging Deceleration time	0000.0s~6500.0s	0020.0	☆	
P0.1.11	Acceleration time 2	0000.0s~6500.0s	Machine type	☆	
P0.1.12	Deceleration time 2	0000.0s~6500.0s	Machine type	☆	
P0.1.13	Acceleration time 3	0000.0s~6500.0s	Machine type	☆	
P0.1.14	Deceleration time 3	0000.0s~6500.0s	Machine type	☆	
P0.1.15	Acceleration time 4	0000.0s~6500.0s	Machine type	☆	
P0.1.16	Deceleration time 4	0000.0s~6500.0s	Machine type	☆	93
P0.1.17	Frequency Switch Point between Acceleration time 1 and Acceleration time 2	000.00Hz~Highest Frequency	000.00	☆	
P0.1.18	Frequency Switch Point between Deceleration time 1 and Deceleration time 2	000.00Hz~Highest Frequency	000.00	☆	
P0.1.19	Acceleration and Deceleration Mode	0: Straight Line 1: Curve S 1 2: Curve S 2	0	★	
P0.1.20	Percentage of Starting Phase of Curve S	000.0%~100.0%	030.0	★	94
P0.1.21	Percentage of Ending Phase of Curve S	000.0%~100.0%	030.0	★	
P0.1.22	Hopping Frequency 1	000.00Hz~Highest Frequency	000.00	☆	
P0.1.23	Hopping Frequency 2	000.00Hz~Highest Frequency	000.00	☆	
P0.1.24	Hopping Frequency scope	000.00Hz~Highest Frequency	000.00	☆	
P0.1.25	Jogging Priority	0: Invalid 1: Valid	0	☆	95
P0.1.26	Type of Encoder	0: ABZ Incremental Encoder 1: UVW Incremental Encoder (Invalid E100) 2: Rotary Transformer (Invalid E100) 3~9: Reservation 10: Distance Control (Open Collector)	00	△/★	
P0.1.27	Line Number of Encoder	00001~65535	01024	△/★	
P0.1.28	ABZ phase sequence	0: Forward Direction 1: Reverse Direction	0	△/★	96
P0.1.29	Encoder Disconnection Testing Time	No action 00.1s~10.0s	00.0	△/★	
P0.1.30	Stator Resistance of Synchronous motor	00.001 Ω ~ 65.535 Ω (inverter power<75kW) 0.0001Ω ~6.5535Ω (inverter power<75kW)	Machine type	▲/★	
P0.1.31	Back EMF of Synchronous motor	0000.0V~6553.5V	Machine type	▲/★	
P0.1.32	UVW Phase Sequence	0: Forward Direction 1: Reverse Direction	Machine type	▲/★	
P0.1.33	UVW Encoder Angle	000.0~359.9	Machine type	▲/★	
P0.1.34	Pole-pairs of Rotary Transformer	00001~65535	Machine type	▲/★	

## 5.2 Group P1 - Motor Control Parameter

Function code	Function name	Setting scope	Factory set value	Modification limit	Reference page
<b>Sort P1.0: Basic Group</b>					
P1.0.00	V/F Curve Mode	0: Straight Line 1: Multi-point Broken Line 2: Square V/F Curve 1 3: Square V/F Curve 2 4: Square V/F Curve 3	0	★	97
P1.0.01	Torque Boost	00.0% (Automatic Torque Boost) 00.1%~30.0%	04.0	☆	
P1.0.02	Cutoff Frequency of Torque Boost	000.00Hz~Highest Frequency	050.00		
P1.0.03	V/F Slip Compensation Gain	000.0%~200.0%	000.0	☆	98
P1.0.04	Velocity Loop Proportional Gain 1	001~100	030	☆	
P1.0.05	Velocity Circulation Integral Time 1	00.01~10.00	00.50	☆	
P1.0.06	Switching Frequency 1	000.00Hz~P1.0.09	005.00	☆	
P1.0.07	Velocity Loop Proportional Gain 2	001~100	020	☆	
P1.0.08	Velocity Circulation Integral Time 2	00.01~10.00	01.00	☆	
P1.0.09	Switching Frequency 2	P1.0.06~Highest Frequency	010.00	☆	99
P1.0.10	Start Mode	0: Direct Start 1: Speed Tracking Mode 2: Brake and Restart	0	☆	
P1.0.11	Speed Tracking Mode	0: Start from Shutdown Frequency 1: Start from Zero Speed 2: Start from Highest Frequency	0	★	
P1.0.12	Start Frequency	00.00Hz~10.00Hz	00.00	☆	100
P1.0.13	Hold Time of Start Frequency	000.0s~100.0s	000.0	★	
P1.0.14	Starting DC Brake Current	000%~100%	000	★	
P1.0.15	Starting DC Brake Time	000.0s~100.0s	000.0	★	
P1.0.16	Stop Mode	0: Stop by Deceleration 1: Free Stop	0	☆	
P1.0.17	Stop DC Braking Initial Frequency	000.00Hz ~ Highest Frequency	000.00	☆	
P1.0.18	Stop DC Braking Waiting Time	000.0s~100.0s	000.0	☆	
P1.0.19	Stop DC Braking Current	000%~100%	000	☆	
P1.0.20	Stop DC Braking Time	000.0s~100.0s	000.0	☆	
P1.0.21	Braking Use Rate	000%~100%	100	☆	
P1.0.22	Carrier Frequency	00.5kHz~16.0kHz	06.0	☆	101
P1.0.23	Fan Control	0: Rotate at running 1: Continuous Running 2: Control based on Temperature	0	★	
P1.0.24	Motor Overload Protection	0: Prohibition 1: Curve 1 2: Curve 2 3: Curve 3	1	☆	102
P1.0.25	Motor Overload Protection Level	00.20~10.00	01.00	☆	
P1.0.26	Motor Overload Alarm System	050%~100%	080	☆	

Function code	Function name	Setting scope	Factory set value	Modification limit	Reference page
Group P1.1: Extension Group					
P1.1.00	Broken Line V/F Point 1 Frequency	000.00Hz~P1.1.02	000.00	★	103
P1.1.01	Broken Line V/F Point 1 Voltage	000.0%~100.0%	000.0	★	
P1.1.02	Broken Line V/F Point 2 Frequency	P1.1.00~P1.1.04	000.00	★	
P1.1.03	Broken Line V/F Point 2 Voltage	000.0%~100.0%	000.0	★	
P1.1.04	Broken Line V/F Point 3 Frequency	P1.1.02~Motor rated frequency	000.00	★	
P1.1.05	Broken Line V/F Point 3 Voltage	000.0%~100.0%	000.0	★	
P1.1.06	V/F Overexcited Gain	000~200	120	☆	
P1.1.07	Vector Control Torque Upper Frequency	0: Digital Reference (P1.1.08) 1: External Terminal VF1 Reference 2: External Terminal VF2 Reference 3: Multiplex Directive Terminal Reference 4: PULS Reference (DI6) 5: Communication Reference 6: MIN (VF1, VF2) 7: MAX (VF1, VF2) 8: Operation Result 1 9: Operation Result 2 10: Operation Result 3 11: Operation Result 4	00	☆	104
P1.1.08	Torque Upper Limit Reference	000.0%~200.0%	150.0	☆	105
P1.1.09	Inversion Control Enable	0: Allow 1: Prohibit	0	☆	
P1.1.10	Forward and Reverse Dead Time	0000.0s~3000.0s	0000.0	☆	
P1.1.11	Power-on Running Selection	0: Running 1: Not Running	0	☆	106
P1.1.12	Droop Control	00.00Hz~10.00Hz	00.00	☆	
P1.1.13	Speed/Torque Control Mode Selection	0: Speed Control 1: Torque Control	0	★	
P1.1.14	Torque Reference Source	0: Digital Reference (P1.1.15) 1: External Terminal VF1 Reference 2: External Terminal VF2 Reference 3: Multiplex Directive Terminal Reference 4: PULS Reference (DI6) 5: Communication Reference 6: MIN (VF1, VF2) 7: MAX (VF1, VF2) 8: Operation Result 1 9: Operation Result 2 10: Operation Result 3 11: Operation Result 4 12: Standby Torque Source 1 13: Standby Torque Source 2	00	★	106
P1.1.15	Torque Digital Reference	-200.0%~200.0%	150.0	☆	108
P1.1.16	Torque Control FWD Frequency Limit	000.00Hz~Highest Frequency	050.00	☆	
P1.1.17	Torque Control REV Frequency Limit	000.00Hz~Highest Frequency	050.00	☆	
P1.1.18	Torque Acceleration Time	0000.0s~6500.0s	0000.0	☆	
P1.1.19	Torque Deceleration Time	0000.0s~6500.0s	0000.0	☆	

## 5.3 Group P2 - Input/Output Terminal Function

Function code	Function name	Setting scope	Factory set value	Modification limit	Reference page
<b>Group P2.0: Basic Group</b>					
P2.0.00	DI1 Terminal Function	0: No Function	01	△/★	109
P2.0.01	DI2 Terminal Function	1: Forward (FWD) 2: Reverse (REV) 3: Three-wire Running Control	02	★	
P2.0.02	DI3 Terminal Function	4: Forward Jogging 5: Reverse Jogging	09	★	
P2.0.03	DI4 Terminal Function	6: Terminal UP 7: Terminal DOWN	10	★	
P2.0.04	DI5 Terminal Function	8: Free Stop 9: Multiplex Directive Terminal 1	11	★	
P2.0.05	DI6 Terminal Function	10: Multiplex Directive Terminal 2 11: Multiplex Directive Terminal 3	08	★	
P2.0.06	DI7 Terminal Function	12: Multiplex Directive Terminal 4 13: Fault Reset (RESET)	00	▲/★	
P2.0.07	DI8 Terminal Function	14: Running Pause 15: External Fault Input	00	▲/★	
P2.0.08	DI9 Terminal Function	16: Acceleration & Deceleration Time Selection Terminal 1 17: Acceleration & Deceleration Time Selection Terminal 2	00	▲/★	
P2.0.09	DI2 Terminal Function	18: Frequency Source Selection Terminal 1 19: Frequency Source Selection Terminal 2 20: Frequency Source Selection Terminal 3 21: Running Command Selection Terminal 1 22: Running Command Selection Terminal 2 23: UP/DOWN Reference Reset 24: Prohibition of Acceleration & Deceleration 25: PID Pause 26: PLC State Reset 27: Wobbling Pause 28: Counter Input 29: Counter Reset 30: Length Counting Input 31: Length Reset 32: Torque Control Prohibition 33: PULS Impulse Input 34: Immediate DC Brake 35: External Fault Normally-closed Input 36: Frequency Modification Enable 37: PID Action Direction Negation 38: External Stop Terminal 1 39: External Stop Terminal 2 40: PID Integral Stop 41: PID Parameter Switch 42: Speed Control/Torque Control Switch 43: Emergency Stop 44: Deceleration DC Brake 45: User-Defined Fault 1 46: User-Defined Fault 2 47: Running Time Reset 48: Timer Input Terminal 1 49: Timer Input Terminal 2 50: Timer Reset Terminal 1 51: Timer Reset Terminal 2 52: Encoder Phase A Input 53: Encoder Phase B Input 54: Distance Reset 55: Integral Computation Reset 56: User Function 1 57: User Function 2 58: User Function 3 59: User Function 4 60: Start by tracing its rpm is prohibited			110

Function code	Function name	Setting scope	Factory set value	Modification limit	Reference page
P2.0.10	DI Filtering time	0.000s~1.000s	0.010	☆	114
P2.0.11	External Terminal Running Control Mode	0: Two-line Type 1 1: Two-line Type 2 2: Three-line Type 1 3: Three-line Type 2	0	★	
P2.0.12	UP/DOWN Terminal Change Rate	00.001Hz/s~65.535Hz/s	01.000	☆	
P2.0.13	Minimum Input of Curve 1	00.00V~P2.0.15	00.00	☆	115
P2.0.14	Corresponding reference for Minimum Input of Curve 1	-100.0%~100.0%	000.0	☆	
P2.0.15	Maximum Input of Curve 1	P2.0.13~10.00V	10.00	☆	
P2.0.16	Corresponding reference for Maximum Input of Curve 1	-100.0%~100.0%	100.0	☆	
P2.0.17	VF1 Filtering time	00.00s~10.00s	00.10	☆	
P2.0.18	Minimum Input of Curve 2	00.00V~P2.0.20	00.00	☆	
P2.0.19	Corresponding reference for Minimum Input of Curve 2	-100.0%~100.0%	000.0	☆	
P2.0.20	Maximum Input of Curve 2	P2.0.18~10.00V	10.00	☆	
P2.0.21	Corresponding reference for Maximum Input of Curve 2	-100.0%~100.0%	100.0	☆	
P2.0.22	VF2 Filtering time	0.00s~10.00s	00.10	☆	
P2.0.23	Minimum Input of PULS	0.00kHz~ P2.0.25	000.00	☆	116
P2.0.24	Corresponding reference for Minimum Input of PULS	-100.0%~100.0%	000.0	☆	
P2.0.25	Maximum Input of PULS	P2.0.23~100.00kHz	050.00	☆	
P2.0.26	Corresponding reference for Maximum Input of PULS	-100.0%~100.0%	100.0	☆	
P2.0.27	PULS Filtering time	00.00s~10.00s	00.10	☆	
P2.0.28	Expansion Card YO1 Function Selection	0: No Function 1: Frequency inverter under Running 2: Fault Stop Output 3: Frequency Level Testing 4: Frequency Reached 5: Zero-speed Running (no output when shut down) 6: Motor Overload Pre-alarm 7: Frequency inverter Overload Pre-alarm 8: Reference Count Value Reached 9: Designated Count Value Reached 10: Length Reached 11: PLC circulation cycle completed 12: Accumulative Running Time Reached 13: Frequency Limit 14: Torque Limit 15: Ready for Running 16: VF1>VF2 17: Upper Frequency Reached	00	▲/☆	
P2.0.29	T1 Relay Function Selection		01	☆	
P2.0.30	T2 Relay Function Selection		02	Δ/☆	
P2.0.31	Expansion Card YO2 Function Selection		00	▲/☆	
P2.0.32	YO Function Selection (Use Terminal YO/FMP as YO,i.e.P2.1.20=1)		00	Δ/☆	

Function code	Function name	Setting scope	Factory set value	Modification limit	Reference page
		18: Lower Frequency Reached (no output when shut down) 19: Undervoltage state output 20: Communication Reference 21: VF1 Output less than Lower Limit 22: VF1 Output more Upper Limit 23: Zero-speed Running 2 (also output when shut down) 24: Accumulative Power-on Time Reached 25: Frequency Level Testing FDT2 Output 26: Frequency 1 Reaches Output 27: Frequency 2 Reaches Output 28: Current 1 Reaches Output 29: Current 2 Reaches Output 30: Timing Reaches Output 31: VF1 Input Overlimit 32: In Off-load 33: In Reverse Running 34: Zero-current State 35: Module Temperature Reached 36: Output Current Overlimit 37: Lower Frequency Reached (also output when shut down) 38: Alarm Output 39: PLC Phase Completed 40: Current Running Time Reached 41: Fault Output (Not Output for Undervoltage) 42: Time of Timer 1 Reached 43: Time of Timer 2 Reached 44: Time of Timer 1 Reached but Time of Timer 2 not Reached 45: User Function 1 46: User Function 2 47: User Function 3 48: User Function 4 49: User Function 5 50: Synchronization Intermediate Relay M1 51: Synchronization Intermediate Relay M2 52: Synchronization Intermediate Relay M3 53: Synchronization Intermediate Relay M4 54: Synchronization Intermediate Relay M5 55: Distance over Zero 56: Distance Set value 1 Reached 57: Distance Set value 2 Reached 58: Operation Result 2 greater than 0 59: Operation Result 4 greater than 0			117
P2.0.33	Analog Output FM1 Reference	0: Running Frequency 1: Reference frequency	00	☆	120
P2.0.34	Analog Output FM2 Reference	2: Output Current 3: Output Torque (Absolute Value of Torque)	01	Δ / ☆	
P2.0.35	FMP Output Reference (Use Terminal YO/FMP as FMP, i.e.P2.1.20=0)	4: Output Power 5: Output Voltage 6: Impulse Input 7: VF1 Voltage 8: VF1 Voltage 9: Keyboard Potentiometer Voltage 10: Actual Length Value 11: Actual Counting Value 12: Communication Reference	00	Δ / ☆	
		13: Motor Speed 14: Output Current 15: Bus line voltage 16: Output Torque 17: Operation Result 1 18: Operation Result 2 19: Operation Result 3 20: Operation Result 4			
P2.0.36	Analog FM1 Output Offset	-100.0% ~ 100.0%	000.0	☆	121
P2.0.37	Analog FM1 Output Gains	-10.00 ~ 10.00	01.00	☆	
P2.0.38	Analog FM2 Output Offset	-100.0% ~ 100.0%	000.0	Δ / ☆	
P2.0.39	Analog FM2 Output Gains	-10.00 ~ 10.00	01.00	Δ / ☆	

Group P2.1: Extension Group					
P2.1.00	Valid Selection 1 of Model Terminal DI 1	0: Active High Level 1: Active Low Level Ones: DI1 (E102 invalid) Tens: DI2 Hundreds: DI3 Thousands: DI4 Ten Thousands: DI5	00000	★	121
P2.1.01	Valid Selection 2 of Model Terminal DI	0: Active High Level 1: Active Low Level Ones: DI6 Tens: DI7 (Invalid E100) Hundreds: DI8 (Invalid E100) Thousands: DI9 (Invalid E100) Ten Thousands: DI10 (Invalid E100)	00000	★	
P2.1.02	Analog Input Curve Selection	Ones: Curve selected for VF1 Tens: Curve selected for VF2 1: Curve 1      2: Curve 2 3: Curve 3      4: Curve 4 Hundreds: VF1 Input resolution Thousands: VF2 Input resolution Ten Thousands: Keyboard Potentiometer input resolution 0:00.01Hz      1:00.02Hz 2:00.05Hz      3:00.10Hz 4:00.20Hz      5:00.50Hz 6:01.00Hz(Keyboard Potentiometer is invalid)	00021	☆	122
P2.1.03	Selection for Curve less than Min. Reference	0: Corresponding Min. Input Reference 1: 0.0% Ones: VF1 Tens: VF2	H.00	☆	
P2.1.04	Min. Input of Curve 3	00.00V~P2.1.06	00.00	☆	
P2.1.05	Corresponding reference for Min. Input of Curve 3	-100.0%~100.0%	000.0	☆	
P2.1.06	Curve 3 Inflection Point 1 Input	P2.1.04~P2.1.08	03.00	☆	
P2.1.07	Corresponding reference for Curve 3 Inflection Point 1 Input	-100.0%~100.0%	030.0	☆	
P2.1.08	Curve 3 Inflection Point 2 Input	P2.1.06~P2.1.10	06.00	☆	
P2.1.09	Corresponding reference for Curve 3 Inflection Point 2 Input	-100.0%~100.0%	060.0	☆	
P2.1.10	Max. input of Curve 3	P2.1.08~10.00V	10.00	☆	
P2.1.11	Corresponding reference for Max. input of Curve 3	-100.0%~100.0%	100.0	☆	
P2.1.12	Min. Input of Curve 4	00.00V~P2.1.14	00.00	☆	
P2.1.13	Corresponding reference for Min. Input of Curve 4	-100.0%~100.0%	-100.0	☆	
P2.1.14	Curve 4 Inflection Point 1 Input	P2.1.12~P2.1.16	03.00	☆	
P2.1.15	Corresponding reference for Curve 4 Inflection Point 1 Input	-100.0%~100.0%	-030.0	☆	
P2.1.16	Curve 4 Inflection Point 2 Input	P2.1.14~P2.1.18	06.00	☆	
P2.1.17	Corresponding reference for Curve 4 Inflection Point 2 Input	-100.0%~100.0%	030.0	☆	
P2.1.18	Max. input of Curve 4	P2.1.16~10.00V	10.00	☆	
P2.1.19	Corresponding reference for Max. input of Curve 4	-100.0%~100.0%	100.0	☆	
P2.1.20	YO/FMP Terminal Function	0: Impulse output (FMP) 1: Open Collector Output (YO)	1	△ / ☆	123
P2.1.21	Highest Frequency of FMP Output	000.01KHz~100.00KHz	050.00	△ / ☆	

Function code	Function name	Setting scope	Factory set value	Modification limit	Reference page
P2.1.22	Valid State of Multi-functional Output Terminal	0: Positive Logic 1: Negative Logic Ones: YO(E102 invalid) Tens: T1 Hundreds: T2(E102 invalid) Thousands: Expansion Card YO1 (Invalid E100) Ten Thousands: Expansion Card YO2 (Invalid E100)	00000	☆	124
P2.1.23	VF1 Terminal Function as Digital Input	00: Use as Normal Analog 01 ~ 59: Digital Input Terminal Function	00	★	
P2.1.24	VF2 Terminal Function as Digital Input	00: Use as Normal Analog 01~59: Digital Input Terminal Function	00	★	
P2.1.25	Valid State Option of VF	0: Active High Level 1: Active Low Level Ones: VF1 Tens: VF2	00	★	124
P2.1.26	DI1 Delay	0.0s~3600.0s	0000.0	△/☆	125
P2.1.27	DI2 Delay	0.0s~3600.0s	0000.0	☆	
P2.1.28	DI3 Delay	0.0s~3600.0s	0000.0	☆	
P2.1.29	YO Delay	0.0s~3600.0s	0000.0	△/☆	
P2.1.30	T1 Delay	0.0s~3600.0s	0000.0	☆	
P2.1.31	T2 Delay	0.0s~3600.0s	0000.0	△/☆	
<b>Group P2.2 Auxiliary Group</b>					
P2.2.00	Accumulative Power-on Reaches Reference Time	00000h~65000h	00000	☆	125
P2.2.01	Accumulative Running Reaches Reference Time	00000h~65000h	00000	☆	
P2.2.02	The reference frequency reaches test width	000.0%~100.0%	000.0	☆	126
P2.2.03	Frequency Test FDT1	000.00Hz~Highest Frequency	050.00	☆	
P2.2.04	FDT1 Lagged Value	000.0%~100.0%	005.0	☆	
P2.2.05	Frequency Test FDT2	000.00Hz~Highest Frequency	050.00	☆	127
P2.2.06	FDT2 Lagged Value	000.0%~100.0%	005.0	☆	
P2.2.07	Any reached frequency tested value 1	000.00Hz~Highest Frequency	050.00	☆	
P2.2.08	Any reached frequency 1 test width	000.0%~100.0%	000.0	☆	
P2.2.09	Any reached frequency tested value 2	000.00Hz~Highest Frequency	050.00	☆	
P2.2.10	Any reached frequency 2 test width	000.0%~100.0%	000.0	☆	
P2.2.11	Zero Current Test Level	000.0%~300.0% (100.0% correspond to rated current of motor)	005.0	☆	128
P2.2.12	Delay Time for Zero Current Test	000.01s~600.00s	000.10	☆	
P2.2.13	Output Current Overlimit Value	00.0: No Test 000.1%~300.0%	200.0	☆	
P2.2.14	Delay Time for Current Overlimit Test	000.00s~600.00s	000.00	☆	
P2.2.15	Current Level Test 1	000.0%~300.0%	100.0	☆	129
P2.2.16	Test Width of Current Level 1	000.0%~300.0%	000.0	☆	
P2.2.17	Current Level Test 2	000.0%~300.0%	100.0	☆	
P2.2.18	Test Width of Current Level 2	000.0%~300.0%	000.0	☆	130
P2.2.19	VF1 Input Lower Limit	00.00V~P2.2.20	03.10	☆	
P2.2.20	VF1 Input Upper Limit	P2.2.19~11.00V	06.80	☆	
P2.2.21	Model Temperature Reaches Reference	000°C~100°C	075	☆	
P2.2.22	Current Running Reaches Reference Time	0000.0 min~6500.0 min	0000.0	★	

5.4 Group P3 - Programmable Function

Function code	Function name	Setting scope	Factory set value	Modification limit	Reference page
<b>Group P3.0: Basic Group</b>					
P3.0.00	Simple PLC Running Mode	0: End of Single Running and Stop 1: End of Single Running and Save Final Value 2: Continuous Running 3: Cycle N Times	0	☆	131
P3.0.01	Cycle number(s), N	00000~65000	00000	☆	
P3.0.02	Option of PLC Power-off Memory	Ones: Option of Power-off Memory 0: No Power-off Memory 1: Power-off Memory Tens: Stop Memory Selection 0: No Stop Memory 1: Stop Memory	00	☆	
P3.0.03	Phase Directive 0	-100.0%~100.0%	000.0	☆	132
P3.0.04	Phase 0 Running Time	0000.0s~6500.0s	0000.0	☆	
P3.0.05	Phase Directive 1	-100.0%~100.0%	000.0	☆	
P3.0.06	Phase 1 Running Time	0000.0s~6500.0s	0000.0	☆	
P3.0.07	Phase Directive 2	-100.0%~100.0%	000.0	☆	
P3.0.08	Phase 2 Running Time	0000.0s~6500.0s	0000.0	☆	
P3.0.09	Phase Directive 3	-100.0%~100.0%	000.0	☆	
P3.0.10	Phase 3 Running Time	0000.0s~6500.0s	0000.0	☆	
P3.0.11	Phase Directive 4	-100.0%~100.0%	000.0	☆	
P3.0.12	Phase 4 Running Time	0000.0s~6500.0s	0000.0	☆	
P3.0.13	Phase Directive 5	-100.0%~100.0%	000.0	☆	
P3.0.14	Phase 5 Running Time	0000.0s~6500.0s	0000.0	☆	
P3.0.15	Phase Directive 6	-100.0%~100.0%	000.0	☆	
P3.0.16	Phase 6 Running Time	0000.0s~6500.0s	0000.0	☆	
P3.0.17	Phase Directive 7	-100.0%~100.0%	000.0	☆	
P3.0.18	Phase 7 Running Time	0000.0s~6500.0s	0000.0	☆	
P3.0.19	Phase Directive 8	-100.0%~100.0%	000.0	☆	
P3.0.20	Phase 8 Running Time	0000.0s~6500.0s	0000.0	☆	
P3.0.21	Phase Directive 9	-100.0%~100.0%	000.0	☆	
P3.0.22	Phase 9 Running Time	0000.0s~6500.0s	0000.0	☆	
P3.0.23	Phase Directive 10	-100.0%~100.0%	000.0	☆	
P3.0.24	Phase 10 Running Time	0000.0s~6500.0s	0000.0	☆	
P3.0.25	Phase Directive 11	-100.0%~100.0%	000.0	☆	
P3.0.26	Phase 11 Running Time	0000.0s~6500.0s	0000.0	☆	

Function code	Function name	Setting scope	Factory set value	Modification limit	Reference page
P3.0.27	Phase Directive 12	-100.0% ~ 100.0%	000.0	☆	132
P3.0.28	Phase 12 Running Time	0000.0s ~ 6500.0s	0000.0	☆	
P3.0.29	Phase Directive 13	-100.0% ~ 100.0%	000.0	☆	
P3.0.30	Phase 13 Running Time	0000.0s ~ 6500.0s	0000.0	☆	
P3.0.31	Phase Directive 14	-100.0% ~ 100.0%	000.0	☆	
P3.0.32	Phase 14 Running Time	0000.0s ~ 6500.0s	0000.0	☆	
P3.0.33	Phase Directive 15	-100.0% ~ 100.0%	000.0	☆	
P3.0.34	Phase 16 Running Time	0000.0s ~ 6500.0s	0000.0	☆	
P3.0.35	Phase 0 attribution	Ones: Acceleration & Deceleration Time Selection (Invalid Multiplex Directive) 0: Acceleration & Deceleration Time 1 1: Acceleration & Deceleration Time 2 2: Acceleration & Deceleration Time 3 3: Acceleration & Deceleration Time 4 Tens: Frequency Source Selection (Valid Multiplex Directive) 0: Current Phase Directive 1: Keyboard Potentiometer 2: Keyboard Frequency Reference 3: VF1 Input 4: VF2 Input 5: PULS Reference (DI6) 6: PID Reference 7: Operation Result 1 8: Operation Result 2 9: Operation Result 3 A: Operation Result 4 Hundreds unit: running direction 0: Default direction 1: Reversed direction	H.000	☆	133
P3.0.36	Phase 1 attribution		H.000	☆	
P3.0.37	Phase 2 attribution		H.000	☆	
P3.0.38	Phase 3 attribution		H.000	☆	
P3.0.39	Phase 4 attribution		H.000	☆	
P3.0.40	Phase 5 attribution		H.000	☆	
P3.0.41	Phase 6 attribution		H.000	☆	
P3.0.42	Phase 7 attribution		H.000	☆	
P3.0.43	Phase 8 attribution		H.000	☆	
P3.0.44	Phase 9 attribution		H.000	☆	
P3.0.45	Phase 10 attribution		H.000	☆	
P3.0.46	Phase 11 attribution		H.000	☆	
P3.0.47	Phase 12 attribution		H.000	☆	
P3.0.48	Phase 13 attribution		H.000	☆	
P3.0.49	Phase 14 attribution		H.000	☆	
P3.0.50	Phase 15 attribution		H.000	☆	
P3.0.51	Simple PLC Running Time Unit		0: Second 1: Hour 2: Minute	0	
<b>Group P3.1: Expansion Group</b>					
P3.1.00	Timing Selection Function	0: Invalid 1: Valid	0	★	134
P3.1.01	Fixed Running Time Selection	0: Digital Reference (P3.1.02) 1: External Terminal VF1 Reference 2: External Terminal VF2 Reference (Analog input range corresponds to P3.1.02)	0	★	
P3.1.02	Fixed Running Time	0000.0min ~ 6500.0min	0000.0	★	
P3.1.03	Wobblulating Reference Mode	0: Relative to Reference frequency 1: Relative to Highest Frequency	0	☆	134
P3.1.04	Wobblulating Range	000.0% ~ 100.0%	000.0	☆	
P3.1.05	Kicking Range	00.0% ~ 50.0%	00.0	☆	
P3.1.06	Wobblulating Cycle	0000.1s ~ 3000.0s	0010.0	☆	
P3.1.07	Rise Time of Wobblulating Triangular Wave	000.1% ~ 100.0%	050.0	☆	
P3.1.08	Reference Length	00000m ~ 65535m	01000	☆	
P3.1.09	Actual Length	00000m ~ 65535m	00000	☆	
P3.1.10	Impulse Count per meter	0000.1 ~ 6553.5	0100.0	☆	
P3.1.11	Reference Count Value	00001 ~ 65535	01000	☆	
P3.1.12	Designated Count Value	00001 ~ 65535	01000	☆	
P3.1.13	Distance Set value 1	-3200.0 ~ 3200.0	0000.0	☆	
P3.1.14	Distance Set value 2	-3200.0 ~ 3200.0	0000.0	☆	
P3.1.15	Impulse Count per Distance	000.00 ~ 600.00	000.00	☆	

Function code	Function name	Setting scope	Factory set value	Modification limit	Reference page
<b>Group P3.2: Built-in Logic PLC Function Group</b>					
P3.2.00	Intermediate Delay Relay Control	0: the input of this relay is determined by this Relay Control Word A 1: the input of this relay is determined by this Relay Control Word B 2: the input of this relay is determined by this Relay Control Word C Ones: Relay 1 (M1) Tens: Relay 2 (M2) Hundreds: Relay 3 (M3) Thousands: Relay 4 (M4) Ten Thousands: Relay 5(M5)	00000	★	135
P3.2.01	Intermediate Relay Control Word A	0: Reference 0 1: Reference 1 Ones: M1 Tens: M2 Hundreds: M3 Thousands: M4 Ten Thousands: M5	00000	☆	
P3.2.02	Intermediate Delay Relay M1 Control Word B	Ones: Control Logic 0: Input 1	00000	★	
P3.2.03	Intermediate Delay Relay M2 Control Word B	1: Input 1 and NOT 2: Input 1 and Input 2 AND	00000	★	
P3.2.04	Intermediate Delay Relay M3 Control Word B	3: Input 1 and Input 2 OR 4: Input 1 and Input 2 XOR	00000	★	
P3.2.05	Intermediate Delay Relay M4 Control Word B	5: the valid reference of Input 1 is valid the valid Reference of Input 2 is invalid	00000	★	
P3.2.06	Intermediate Delay Relay M5 Control Word B	6. Valid reference of Input 1 Rise Edge is valid Valid reference of Input 2 Rise Edge is invalid 7: Reverse valid signal of Input 1 Rising Edge 8: Input 1 Rise Edge is valid and output a impulse signal with width of 200ms 9: Input 1 Rise Edge and Input 2 AND Hundreds Tens: set the option for Input 1 0~9: DI1~DI10 10~14: M1~M5 15~16: VF1, VF2 17~19: Standby 20 ~ 79 : Output Function 00~59 Corresponding to Multi-functional Output Terminal Ten Thousands Thousands : set the option for Input 2 0~9: DI1~DI10 10~14: M1~M5 15~16: VF1, VF2 17~19: Standby 20 ~ 59 : Output Function 00~39 Corresponding to Multi-functional Output Terminal	00000	★	136

Function code	Function name	Setting scope	Factory set value	Modification limit	Reference page
P3.2.07	Intermediate Delay Relay M1 Control Word C	Tens Ones:00~59	0000	★	137
P3.2.08	Intermediate Delay Relay M2 Control Word C	Output Function 00~59 Corresponding to Digital Input Terminal	0000	★	
P3.2.09	Intermediate Delay Relay M3 Control Word C	Thousands Hundreds	0000	★	
P3.2.10	Intermediate Delay Relay M4 Control Word C	Output Function 00~59	0000	★	
P3.2.11	Intermediate Delay Relay M5 Control Word C	Corresponding to Multi-functional Output Terminal	0000	★	
P3.2.12	M1 Connection Delay Time	0.0s~3600.0s	0000.0	☆	137
P3.2.13	M2 Connection Delay Time	0.0s~3600.0s	0000.0	☆	
P3.2.14	M3 Connection Delay Time	0.0s~3600.0s	0000.0	☆	
P3.2.15	M4 Connection Delay Time	0.0s~3600.0s	0000.0	☆	
P3.2.16	M5 Connection Delay Time	0.0s~3600.0s	0000.0	☆	
P3.2.17	M1 Disconnection Delay Time	0.0s~3600.0s	0000.0	☆	
P3.2.18	M2 Disconnection Delay Time	0.0s~3600.0s	0000.0	☆	
P3.2.19	M3 Disconnection Delay Time	0.0s~3600.0s	0000.0	☆	
P3.2.20	M4 Disconnection Delay Time	0.0s~3600.0s	0000.0	☆	
P3.2.21	M5 Disconnection Delay Time	0.0s~3600.0s	0000.0	☆	
P3.2.22	Valid State Option of Intermediate Relay	0: Not Negation 1: Negation Ones: M1 Tens: M2 Hundreds: M3 Thousands: M4 Ten Thousands: M5	00000	☆	
P3.2.23	Internal Timer Control Word	Ones: Timing Control 1 of Timer Tens: Timing Control 2 of Timer 0: Timer Running 1: Controlled by Timer Input Terminal 1 2: Negation Control of Timer Input Terminal 1 3: Controlled by Timer Input Terminal 2 4: Negation Control of Timer Input Terminal 2 Hundreds: Timer 1 Reset Control Thousands: Timer 2 Reset Control 0: Controlled by Timer Reset Terminal 1 1: Controlled by Timer Reset Terminal 2 Ten Thousands: Timing Unit 0: Second 1: Minute 2: Hour	00000	☆	138
P3.2.24	Timing Time of Timer 1	0.0s~3600.0s	0000.0	☆	
P3.2.25	Timing Time of Timer 2	0.0s~3600.0s	0000.0	☆	

Function code	Function name	Setting scope	Factory set value	Modification limit	Reference page
P3.2.26	Operation Module	0: No Operation 1: Add Operation 2: Subtraction Operation 3: Multiply Operation 4: Division Operation 5: Greater than Judgment 6: Equal to Judgment 7: Equal to or Greater than Judgment 8: Integration 9~F: Reservation Ones: Operation 1 Tens: Operation 2 Hundreds: Operation 3 Thousands: Operation 4	H.0000	☆	
P3.2.27	Operation Setting Coefficient Property	0: Operate the Setting Coefficient by multiplication without decimal 1: Operate the Setting Coefficient by multiplication with one decimal 2: Operate the Setting Coefficient by multiplication with two decimals 3: Operate the Setting Coefficient by multiplication with three decimals 4: Operate the Setting Coefficient by multiplication with four decimals 5: Operate the Setting Coefficient by division without decimal 6: Operate the Setting Coefficient by division with one decimal 7: Operate the Setting Coefficient by division with two decimals 8: Operate the Setting Coefficient by division with three decimals 9: Operate the Setting Coefficient by division with four decimals A: Operate the Setting Coefficient by division without decimal B: Operate the Setting Coefficient by division with one decimal C: Operate the Setting Coefficient by division with two decimals D: Operate the Setting Coefficient by division with three decimals E: Operate the Setting Coefficient by division with four decimals (The setting coefficient of A, B, C, D, E is the address number of function code) Ones: Operation 1 Tens: Operation 2 Hundreds: Operation 3 Thousands: Operation 4	H.0000	☆	139
P3.2.28	Input A of Operation 1	Thousands, Hundreds, Tens and Ones: express address of Input A of Operation 1 Ten Thousands: express input operation model 0: Input is operation by unsigned number 1: Input is operation by signed number	00000	☆	140

Function code	Function name	Setting scope	Factory set value	Modification limit	Reference page
P3.2.29	Input B of Operation 1	Thousands, Hundreds, Tens and Ones: express address of Input B of Operation 1 Ten Thousands: express input operation model 0: Input is operation by unsigned number 1: Input is operation by signed number	00000	☆	140
P3.2.30	Setting Coefficient of Operation 1	00000~65535	00001	☆	
P3.2.31	Input A of Operation 2	Thousands, Hundreds, Tens and Ones: express address of Input A of Operation 2 Ten Thousands: express input operation model 0: Input is operation by unsigned number 1: Input is operation by signed number	00000	☆	
P3.2.32	Input B of Operation 2	Thousands, Hundreds, Tens and Ones: express address of Input B of Operation 1 Ten Thousands: express input operation model 0: Input is operation by unsigned number 1: Input is operation by signed number	00000	☆	141
P3.2.33	Setting Coefficient of Operation 2	00000~65535	00001	☆	
P3.2.34	Input A of Operation 3	Thousands, Hundreds, Tens and Ones: express address of Input A of Operation 3 Ten Thousands: express input operation model 0: Input is operation by unsigned number 1: Input is operation by signed number	00000	☆	
P3.2.35	Input B of Operation 3	Thousands, Hundreds, Tens and Ones: express address of Input B of Operation 3 Ten Thousands: express input operation model 0: Input is operation by unsigned number 1: Input is operation by signed number	00000	☆	
P3.2.36	Setting Coefficient of Operation 3	00000~65535	00001	☆	
P3.2.37	Input A of Operation 4	Thousands, Hundreds, Tens and Ones: express address of Input A of Operation 4 Ten Thousands: express input operation model 0: Input is operation by unsigned number 1: Input is operation by signed number	00000	☆	
P3.2.38	Input B of Operation 4	Thousands, Hundreds, Tens and Ones: express address of Input B of Operation 4 Ten Thousands: express input operation model 0: Input is operation by unsigned number 1: Input is operation by signed number	00000	☆	
P3.2.39	Setting Coefficient of Operation 4	00000~65535	00001	☆	

## 5.5 Group P4 - PID Control And Communication Control

Function code	Function name	Setting scope	Factory set value	Modification limit	Reference page
<b>Group P4.0: PID Control Group</b>					
P4.0.00	PID Reference Source	0: Digital Reference (P4.0.01) 1: Keyboard Potentiometer Reference 2: External Terminal VF1 Reference 3: External Terminal VF2 Reference 4: PULS Reference (DI6) 5: Communication Reference 6: Multiplex Directive Terminal Reference 7: Simple PLC Reference 8: Operation Result 1 9: Operation Result 2 10: Operation Result 3 11: Operation Result 4	00	☆	142
P4.0.01	PID Value Reference	000.0% ~ 100.0%	050.0	☆	
P4.0.02	PID Feedback Source	0: External Terminal VF1 Reference 1: External Terminal VF1 Reference 2: VF1-VF2 3: VF1+VF2 4: PULS Reference (DI6) 5: Communication Reference 6: MAX[VF1, VF2] 7: MIN[VF1, VF2] 8: Switch of Multiplex Directive Terminal on the above conditions 9: Operation Result 1 10: Operation Result 2 11: Operation Result 3 12: Operation Result 4	00	☆	143
P4.0.03	PID Action Direction	0: Direct Action 1: Reverse Action	0	☆	
P4.0.04	PID Reference Feedback Range	00000 ~ 65535	01000	☆	145
P4.0.05	Proportional Gains KP1	000.0 ~ 100.0	020.0	☆	
P4.0.06	Integral Time TI1	00.01s ~ 10.00s	02.00	☆	
P4.0.07	Derivative Time TD1	00.000s ~ 10.000s	00.000	☆	
P4.0.08	PID Deviation Limit	000.0% ~ 100.0%	000.0	☆	
P4.0.09	PID Feedback Filtering time	00.00s ~ 60.00s	00.00	☆	
P4.0.10	Proportional Gains KP2	000.0 ~ 100.0	020.0	☆	146
P4.0.11	Integral Time TI2	00.01s ~ 10.00s	02.00	☆	
P4.0.12	Derivative Time TD2	00.000s ~ 10.000s	00.000	☆	
P4.0.13	PID Switch Conditions	0: No Switch 1: Switch through Terminals 2: Switch through Deviation	0	☆	146
P4.0.14	PID Switch Deviation 1	000.0% ~ P4.0.15	020.0	☆	
P4.0.15	PID Switch Deviation 2	P4.0.14 ~ 100.0%	080.0	☆	
P4.0.16	PID Initial Value	000.0% ~ 100.0%	000.0	☆	
P4.0.17	PID Initial Value Hold Time	000.00 ~ 650.00s	000.00	☆	
P4.0.18	PID Feedback Loss Test	000.0%: No Judgment on Feedback Loss 000.1% ~ 100.0%	000.0	☆	147
P4.0.19	PID Feedback Loss Test Time	00.0s ~ 20.0s	00.0	☆	
P4.0.20	PID Stop Operation	0: No Operation 1: Operation	0	☆	148

Group P4.1: Communication Group					
P4.1.00	Baud Rate	Ones unit: MODBUS baud rate 0: 1200 1: 2400 2: 4800 3: 9600 4: 19200 5: 38400 6: 57600 Tens unit: PROFIBUS baud rate 0: 115200 1: 208300 2: 256000 3: 512000	3	☆	148
P4.1.01	Data Format	0: No Verification (8-N-2) 1: Even Parity Verification (8-E-1) 2: Odd Parity Verification (8-O-1) 3: No Verification (8-N-1)	0	☆	
P4.1.02	Local Machine Address	000: Broadcast Address 001~249	001	☆	
P4.1.03	Response Delay	00~20ms	02	☆	
P4.1.04	Communication Timeout	00.0 (Invalid) 00.1s~60.0s	00.0	☆	
P4.1.05	Data Transmission Format	Ones unit: MODBUS data format 0: ASCII Mode (Reservation) 1: RTU Mode Tens unit: PROFIBUS data format 0: PPO1 1: PPO2 2: PPO3 3: PPO5	1	☆	148
P4.1.06	MODBUS communication data reply or not	0: Reply 1: No reply	0	☆	

## 5.6 Group P5 - Keyboard Display

Function code	Function name	Setting scope	Factory set value	Modification limit	Reference page
<b>Group P5.0: Basic Group</b>					
P5.0.00	Keyboard JOG Key Function Reference	0: Invalid 1: Forward Jogging 2: Reverse Jogging 3: Forward and Reverse Switch	1	★	
P5.0.01	Keyboard STOP Key Stop Function	0: Only valid in Keyboard Operation Mode 1: Valid for any Mode	1	☆	
P5.0.02	LED Running Display Parameter 1	H.0001~H.FFFF Bit00: Running Frequency (Hz) Bit01: Reference frequency (Hz) Bit02: Output Current (A) Bit03: Output Voltage (V) Bit04: Bus line voltage (V) Bit05: Output Torque (%) Bit06: Output Power (kW) Bit07: Input Terminal State Bit08: Output Terminal State Bit09: VF1 Voltage (V) Bit10: VF2 Voltage (V) Bit11: Customized Display Value Bit12: Actual Count Value Bit13: Actual Length Value Bit14: PID Reference Bit15: PID Feedback	H.001F	☆	
P5.0.03	LED Running Display Parameter 2	H.0000~H.FFFF Bit00: Impulse frequency (0.01kHz) Bit01: Feedback Speed (Hz) Bit02: PLC Phase Bit03: VF1 Voltage before Correction (V) Bit04: VF2 Voltage before Correction (V) Bit05: Line Speed Bit06: Current Power-on Time (min) Bit07: Current Running Time (min) Bit08: Residual Running Time (min) Bit09: Frequency of Frequency Source A(Hz) Bit10: Frequency of Frequency Source B(Hz) Bit11: Communication Set value (Hz) Bit12: Impulse frequency (Hz) Bit13: Encoder Feedback Speed (r/min) Bit14: Actual Distance Value Bit15: User Standby Monitoring Value 1	H.0000	☆	
P5.0.04	Automatic Time Switch of LED Running Display Parameter	000.0: No Switch 000.1s~100.0s	000.0	☆	

Function code	Function name	Setting scope	Factory set value	Modification limit	Reference page
P5.0.05	LED Stop Display Parameter	H.0001~H.FFFF Bit00: Reference frequency (Hz) Bit01: Bus line voltage (V) Bit02: Input Terminal State Bit03: Output Terminal State Bit04: VF1 Voltage (V) Bit05: VF2 Voltage (V) Bit06: Actual Count Value Bit07: Actual Length Value Bit08: PLC Phase Bit09: Customized Display Value Bit10: PID Reference Bit11: PID Feedback Bit12: Impulse frequency (Hz) Bit13: User Standby Monitoring Value 1 Bit14: Reservation Bit15: Reservation	H.0033	☆	151
P5.0.06	LCD Line 1 Display at Running	0000~9399	9001	☆	151
P5.0.07	LCD Line 2 Display at Running	0000~9399	9000	☆	
P5.0.08	LCD Line 3 Display at Running	0000~9399	9002	☆	
P5.0.09	LCD Line 4 Display at Running	0000~9399	9003	☆	
P5.0.10	LCD Line 1 Display at Stop	0000~9399	9001	☆	
P5.0.11	LCD Line 2 Display at Stop	0000~9399	9000	☆	152
P5.0.12	LCD Line 3 Display at Stop	0000~9399	9004	☆	
P5.0.13	LCD Line 4 Display at Stop	0000~9399	0000	☆	
P5.0.14	LCD Chinese/English Display Switch	0: Chinese      1: English	0	☆	75
P5.0.15	Customized Display of Coefficient	0.0001~6.5000	1.0000	☆	
P5.0.16	User-defined display control word.	Ones unit: user-defined decimal place displaying 0: zero decimal place 1: one decimal place 2: two decimal places 3: three decimal places Tens unit: source of user-defined display value 0: determined by hundreds place of user-defined display control word. 1: determined by set value of P5.0.15, and 0.0000~0.0099 corresponds to P9.0.00 ~ P9.0.99 of P9 Group. Hundreds unit: selection of user-defined displaying coefficient 0: user-defined displaying coefficient is P5.0.15. 1: user-defined displaying coefficient is calculation result 1 2: user-defined displaying coefficient is calculation result 2 3: user-defined displaying coefficient is calculation result 3 4: user-defined displaying coefficient is calculation result 4	001	☆	

Function code	Function name	Setting scope	Factory set value	Modification limit	Reference page
P5.0.17	Selection Display of Function Parameter Group	Ones: 0: Only display basic group 1: Display the menus at all levels Tens 0: Don't display Group P7 1: Display Group P7 2: Reservation Hundreds: 0: Don't display correction parameter group 1: Display correction parameter group Thousands: 0: Don't display code group 1: Display code group Ten Thousands: Reservation	00011	☆	153
P5.0.18	Function Password Protection	0: Modifiable 1: Non-modifiable 2: Allowable Modification to GP Type	0	☆	154
P5.0.19	Parameter Initialization	00: No Operation 01: Clearance of Record Information 09: Recover Factory set value, excluding motor parameter, correction group, password group 19: Recover Factory set value, excluding motor parameter, password group 30: Users Current Parameter Backup 60: User Backup Parameters Recovery 100~999: User factory set values recovery	000	★	
P5.0.20	User Password	00000~65535	00000	☆	155
<b>Group P.5.1 Expansion Group</b>					
P5.1.00	Accumulative Running Time	00000h~65000h		●	155
P5.1.01	Accumulative Power On Time	00000h~65000h		●	
P5.1.02	Accumulative Power Consumption	00000°C~65000°C		●	
P5.1.03	Module Temperature	000°C~100°C		●	
P5.1.04	Hardware Version No.	180.00		●	
P5.1.05	Software Version No.	001.00		●	
P5.1.06	Program Nonstandard Label	0000~9999		●	

## 5.7 Group P6 - Fault Display and Protection

Function code	Function name	Setting scope	Factory set value	Modification limit	Reference page
<b>Group P6.0: Fault Display Group</b>					
P6.0.00	Fault Record 1 (Last Time)	0: No Fault		•	156
P6.0.01	Fault Record 2	1: Constant Overcurrent 2: Accelerated Overcurrent		•	
P6.0.02	Fault Record 3	3: Decelerated Overcurrent 4: Constant Overvoltage 5: Accelerated Overvoltage 6: Decelerated Overvoltage 7: Module Fault 8: Undervoltage 9: Frequency inverter Overload 10: Motor Overload 11: Input Default Phase 12: Output Default Phase 13: External Fault 14: Communication Abnormity 15: Frequency inverter Overheat 16: Frequency inverter Hardware Fault 17: Motor-to-ground Short Circuit 18: Motor Identification Error 19: Motor Off-load 20: PID Feedback Loss 21: User Customerized Fault 1 22: User Customerized Fault 2 23: Power-on Time Reached 24: Running Time Reached 25: Encoder Fault 26: Parameter Read-Write Abnormity 27: Motor Overheat 28: Larger Speed Deviation 29: Motor Overspeed 30: Initial Position Error 31: Current Test Fault 32: Contactor 33: Abnormity of Current Test 34: Fast Current-limiting Timeout 35: Motor Switch at Running 36: 24V Power Fault 37: Driving power supply fault 38~39: Reservation 40: Buffer Resistance Fault		•	

Function code	Function name	Setting scope	Factory set value	Modification limit	Reference page	
P6.0.03	Fault Frequency 1			●	156	
P6.0.04	Fault Current 1			●		
P6.0.05	Bus line voltage 1 when at Fault			●		
P6.0.06	Input Terminal State 1 when at fault			●		
P6.0.07	Output Terminal State 1 when at fault			●		
P6.0.08	Frequency inverter State 1 when at fault			●		
P6.0.09	Power-on Time 1 when at fault			●		
P6.0.10	Running Time 1 when at fault			●		
P6.0.11	Fault Frequency 2			●		157
P6.0.12	Fault Current 2			●		
P6.0.13	Bus line voltage 2 when at Fault			●		
P6.0.14	Input Terminal State 2 when at fault			●		
P6.0.15	Output Terminal State 2 when at fault			●		
P6.0.16	Frequency inverter State 2 when at fault			●		
P6.0.17	Power-on Time 2 when at fault			●		
P6.0.18	Running Time 2 when at fault			●		
P6.0.19	Fault Frequency 3			●		
P6.0.20	Fault Current 3			●		
P6.0.21	Bus line voltage 3 when at Fault			●		
P6.0.22	Input Terminal State 3 when at fault			●		
P6.0.23	Output Terminal State 3 when at fault			●		
P6.0.24	Frequency inverter State 3 when at fault			●		
P6.0.25	Power-on Time 3 when at fault			●		
P6.0.26	Running Time 3 when at fault			●		
<b>Group 6.1: Protection Control Group</b>						
P6.1.00	Input Default Phase Protection	0: Prohibited 1: Allowed	1	☆	157	
P6.1.01	Output Default Phase Protection	0: Prohibited 1: Allowed	1	☆		
P6.1.02	Overvoltage Stall Protection Sensitivity	0~100	5	☆	158	
P6.1.03	Overvoltage Stall Protection Voltage Point	120% ~ 150%	130	☆		
P6.1.04	Overcurrent Stall Protection Sensitivity	0~100	020	☆		
P6.1.05	Overcurrent Stall Protection current	100% ~ 200%	150	☆		
P6.1.06	Fault Auto Reset Number	0~20	00	☆		
P6.1.07	Waiting Interval Time of Fault Auto Reset	0.1s ~ 100.0s	001.0	☆		

Function code	Function name	Setting scope	Factory set value	Modification limit	Reference page
P6.1.08	Fault Protective Action Selection 1	0: Free Stop 1: Stop by its Mode 2: Continuous Running Ones: Motor Overload Tens: Input Default Phase Hundreds: Output Default Phase Thousands: External Default Ten Thousands: Communication Abnormality	00000	☆	159
P6.1.09	Fault Protective Action Selection 2	0: Free Stop 1: Stop by its Mode 2: Continuous Running Ones: Motor Overload Tens: Feedback Loss Hundreds: User Customized Fault 1 Thousands: User Customized Fault 2 Ten Thousands: Power-on Time Reached	00000	★	
P6.1.10	Fault Protective Action Selection 3	Ones: Running Time Reached 0: Free Stop 1: Stop by its Mode 2: Continuous Running Tens: Encoder Abnormality 0: Free Stop Hundreds: Parameter Read-Write Abnormity 0: Free Stop 1: Stop by its Mode Thousands: Motor Overhear 0: Free Stop 1: Stop by its Mode 2: Continuous Running Ten Thousands: Fault of 24V Power Supply 0: Free Stop 1: Stop by its Mode	00000	☆	
P6.1.11	Fault Protective Action Selection 4	0: Free Stop 1: Stop by its Mode 2: Continuous Running Ones: Larger Speed Deviation Tens: Motor Overspeed Hundreds: Initial Position Error Thousands: Reservation Ten Thousands: Reservation	00000	☆	

Function code	Function name	Setting scope	Factory set value	Modification limit	Reference page
P6.1.12	Continuous Running Frequency Selection when at Fault	0: Running at Current Frequency 1: Running at Reference frequency 2: Running at Upper Frequency 3: Running at Lower Frequency 4: Running at Back Frequency for Abnormality	0	☆	160
P6.1.13	Backup Frequency for Abnormality	000.0% ~ 100.0%	100.0	☆	
P6.1.14	Action Selection for Momentary Interruption	0: Invalid 1: Deceleration 2: Stop by Deceleration	0	☆	161
P6.1.15	Judgment Time of Momentary Interruption Voltage Recovery	000.00s ~ 100.00s	000.50	☆	
P6.1.16	Voltage Judgment for Momentary Interruption Action	60.0% ~ 100.0% (Standard Bus line voltage)	080.0	☆	
P6.1.17	Voltage Judgment for Suspension of Momentary Action	80.0% ~ 100.0% (Standard Bus line voltage)	090.0	☆	
P6.1.18	Off-load Protection Selection	0: Valid      1: Invalid	0	☆	
P6.1.19	Off-load Test Level	000.0% ~ 100.0%	010.0	☆	162
P6.1.20	Off-load Test Time	00.0s ~ 60.0s	01.0	☆	
P6.1.21	Overspeed Test	00.0% ~ 50.0%	20.0	☆	
P6.1.22	Overspeed Test Time	00.0: No Test 00.1s ~ 60.0s	01.0	☆	
P6.1.23	Speed Deviation greater than Test Value	00.0% ~ 50.0%	20.0	☆	
P6.1.24	Speed Deviation greater than Test Time	00.0: No Test 00.1s ~ 60.0s	05.0	☆	
P6.1.25	Fault Output Terminal Action Selection during Fault Auto Reset Period	0: No Action 1: Action	0	☆	
P6.1.26	Input Default Phase Protection Sensitivity	01~10 (The smaller it is, the more sensitivity it is)	05	☆	

## 5.8 Group P7 - User Function Customization

Function code	Function name	Setting scope	Factory set value	Modification limit	Reference page
Group P7.0: Basic Group					
P7.0.00	User Function 0	U0.0.01	U0.001	●	163
P7.0.01	User Function 1	U0.0.00~UX.X.XX (exclude P7, P8)	U0.002	☆	
P7.0.02	User Function 2	U0.0.00~UX.X.XX (exclude P7, P8)	U0.003	☆	
P7.0.03	User Function 3	U0.0.00~UX.X.XX (exclude P7, P8)	U0.007	☆	
P7.0.04	User Function 4	U0.0.00~UX.X.XX (exclude P7, P8)	U0.008	☆	
P7.0.05	User Function 5	U0.0.00~UX.X.XX (exclude P7, P8)	U0.017	☆	
P7.0.06	User Function 6	U0.0.00~UX.X.XX (exclude P7, P8)	U0.018	☆	
P7.0.07	User Function 7	U0.0.00~UX.X.XX (exclude P7, P8)	U0.000	☆	
P7.0.08	User Function 8	U0.0.00~UX.X.XX (exclude P7, P8)	U0.000	☆	
P7.0.09	User Function 9	U0.0.00~UX.X.XX (exclude P7, P8)	U0.000	☆	
P7.0.10	User Function 10	U0.0.00~UX.X.XX (exclude P7, P8)	U0.000	☆	
P7.0.11	User Function 11	U0.0.00~UX.X.XX (exclude P7, P8)	U0.000	☆	
P7.0.12	User Function 12	U0.0.00~UX.X.XX (exclude P7, P8)	U0.000	☆	
P7.0.13	User Function 13	U0.0.00~UX.X.XX (exclude P7, P8)	U0.000	☆	
P7.0.14	User Function 14	U0.0.00~UX.X.XX (exclude P7, P8)	U0.000	☆	
P7.0.15	User Function 15	U0.0.00~UX.X.XX (exclude P7, P8)	U0.000	☆	
P7.0.16	User Function 16	U0.0.00~UX.X.XX (exclude P7, P8)	U0.000	☆	
P7.0.17	User Function 17	U0.0.00~UX.X.XX (exclude P7, P8)	U0.000	☆	
P7.0.18	User Function 18	U0.0.00~UX.X.XX (exclude P7, P8)	U0.000	☆	
P7.0.19	User Function 19	U0.0.00~UX.X.XX (exclude P7, P8)	U0.000	☆	
P7.0.20	User Function 20	U0.0.00~UX.X.XX (exclude P7, P8)	U0.000	☆	
P7.0.21	User Function 21	U0.0.00~UX.X.XX (exclude P7, P8)	U0.000	☆	
P7.0.22	User Function 22	U0.0.00~UX.X.XX (exclude P7, P8)	U0.000	☆	
P7.0.23	User Function 23	U0.0.00~UX.X.XX (exclude P7, P8)	U0.000	☆	
P7.0.24	User Function 24	U0.0.00~UX.X.XX (exclude P7, P8)	U0.000	☆	
P7.0.25	User Function 25	U0.0.00~UX.X.XX (exclude P7, P8)	U0.000	☆	
P7.0.26	User Function 26	U0.0.00~UX.X.XX (exclude P7, P8)	U0.000	☆	
P7.0.27	User Function 27	U0.0.00~UX.X.XX (exclude P7, P8)	U0.000	☆	
P7.0.28	User Function 28	U0.0.00~UX.X.XX (exclude P7, P8)	U0.000	☆	
P7.0.29	User Function 29	U0.0.00~UX.X.XX (exclude P7, P8)	U0.000	☆	

## 5.9 Group P8 - Manufacturer Function

Function code	Function name	Setting scope	Factory set value	Modification limit	Reference page
<b>Group P8.0: Manufacturer Function Group</b>					
P8.0.00	Manufacturer Code	00000~65535	00000	☆	164
<b>Sort P8.1: Parameter Correction Sort</b>					
P8.1.00	Voltage Input of Potentiometer Correction Point 1	00.00V~P8.1.02	00.00	☆	164
P8.1.01	Corresponding reference of Potentiometer Correction Point 1	-100.0%~100.0%	000.0	☆	
P8.1.02	Voltage Input of Potentiometer Correction Point 2	P8.1.00~10.00V	10.00	☆	
P8.1.03	Corresponding reference of Potentiometer Correction Point 2	-100.0%~100.0%	100.0	☆	
P8.1.04	Filtering time of potentiometer	00.00s~10.00s	00.10	☆	
P8.1.05	VF1 actual voltage 1	0.500V~4.000V	2.000	☆	
P8.1.06	VF1 indicated voltage 1	0.500V~4.000V	2.000	☆	
P8.1.07	VF1 actual voltage 2	6.000V~9.999V	8.000	☆	
P8.1.08	VF1 indicated voltage 2	6.000V~9.999V	8.000	☆	
P8.1.09	VF2 actual voltage 1	0.500V~4.000V	2.000	☆	
P8.1.10	VF2 indicated voltage 1	0.500V~4.000V	2.000	☆	
P8.1.11	VF2 actual voltage 2	6.000V~9.999V	8.000	☆	
P8.1.12	VF2 indicated voltage 2	6.000V~9.999V	8.000	☆	
P8.1.13	FM1 target voltage 1	0.500V~4.000V	2.000	☆	165
P8.1.14	FM1 actual voltage 1	0.500V~4.000V	2.000	☆	
P8.1.15	FM1 target voltage 2	6.000V~9.999V	8.000	☆	
P8.1.16	FM1 target voltage 2	6.000V~9.999V	8.000	☆	
P8.1.17	FM2 target voltage 1	0.500V~4.000V	2.000	Δ /☆	
P8.1.18	FM2 target voltage 1	0.500V~4.000V	2.000	Δ /☆	
P8.1.19	FM2 target voltage 2	6.000V~9.999V	8.000	Δ /☆	
P8.1.20	FM2 target voltage 2	6.000V~9.999V	8.000	Δ /☆	

## 5.10 Group P9 - Monitoring Parameter

Function code	Function Name	Setting scope	Factory set value	Modification limit	Reference page
Sort P9.0: Basic Monitoring Parameter					
P9.0.00	Running Frequency			●	166
P9.0.01	Reference frequency			●	
P9.0.02	Output Current			●	
P9.0.03	Output Voltage			●	
P9.0.04	Bus line voltage			●	
P9.0.05	Output Torque			●	
P9.0.06	Output Power			●	166
P9.0.07	Input Terminal Status			●	
P9.0.08	Output Terminal Status			●	
P9.0.09	VF1 Voltage			●	
P9.0.10	VF2 Voltage			●	
P9.0.11	Custom Display Value			●	
P9.0.12	Actual Counting Value			●	
P9.0.13	Actual Length Value			●	
P9.0.14	PID Reference			●	
P9.0.15	PID Feedback			●	
P9.0.16	PULS Impulse frequency			●	
P9.0.17	Feedback Speed			●	
P9.0.18	PLC Phase			●	
P9.0.19	Voltage before VF1 Correction			●	
P9.0.20	Voltage before VF2 Correction			●	
P9.0.21	Line Speed			●	
P9.0.22	Current Power-on Time			●	
P9.0.23	Current Running Time			●	
P9.0.24	Residual Running Time			●	
P9.0.25	Frequency of Frequency Source A			●	167
P9.0.26	Frequency of Frequency Source B			●	
P9.0.27	Communication Set value			●	
P9.0.28	Impulse frequency			●	
P9.0.29	Encoder Feedback Speed			●	
P9.0.30	Actual Distance Value			●	
P9.0.31~ P9.0.45	Reservation			●	
P9.0.46	Operation Result 1			●	
P9.0.47	Operation Result 2			●	
P9.0.48	Operation Result 3			●	
P9.0.49	Operation Result 4			●	
P9.0.50	User Standby Monitoring Value 1			●	
P9.0.51	User Standby Monitoring Value 2			●	
P9.0.52	User Standby Monitoring Value 3			●	
P9.0.53	User Standby Monitoring Value 4			●	
P9.0.54	User Standby Monitoring Value 5			●	

## Chapter 6. Description of Parameters

## 6.1 Group 0 - Basic Function

## P0.0 Group – Basic Group

Function code	Function Name	Setting scope	Factory set value
P0.0.00	Type of Frequency inverter	1:G Type (constant torque load type) 2:P Type (fans and water pump load type)	Type

This function code is only for the users to check the factory type of the frequency inverter and is generally not allowed to be modified by the users. If modification is required, the function code P5.0.18 **must** be first changed to 2.

- 1: G Type      applicable for constant torque load 80  
2: P Type      applicable for fans and water pump load

Function code	Function Name	Setting scope	Factory set value
P0.0.01	Display Mode	0:Basic Mode (Prefix with 'P') 1:User Mode (Prefix with 'U') 2:Verification Mode (Prefix with 'C')	0

This function code is used for confirming what a kind of display modes is selected for inventor

0: Basic Mode (Prefix with 'P')

The frequency inverter specifically displays what parameters of the function codes are determined by Function Code P5.0.17 (Refer to the description for Function Code P5.0.17 for more details)

1: User Mode (Prefix with 'U')

Only display customization parameters of user function and use Function Code of Group P7.0 to determine what parameters of the function codes are specifically displayed by the frequency inverter (Refer to the description for Group P7.0 for more details). In user mode, the function code has the prefix with 'U'.

2: Verification Mode (Prefix with 'C')

Only display the modified parameters (in case of any difference of function code between reference value and factory set value, it is deemed that the parameters are changed), the function code has the prefix with 'C' at this time.

**Note: no matter what the prefix is, 'P' or 'U' or 'C', the meaning of their relative parameters is the same and the prefix is only for distinguishing the display mode.**

Function code	Function Name	Setting scope	Factory set value
P0.0.02	Control Mode	0:V/F Control 1: Open-loop Vector Control (SVC) 2: Closed-loop Vector Control (Invalid E100)	0

0:V/FC control

Be applicable for the occasions without high requirements to load or where one set of frequency inverter drives more than one set of motor.

1: SVC

Don't need to externally connect the encoder as speed feedback and be applicable for general and high-powered occasions, one set of frequency inverter only drives one set of motor.

2: VC

Need to externally connect the encoder as speed feedback and be applicable for occasions with high-precision speed control or torque control, one set of frequency inverter only drives one set of motor. This function is not available on E100 and E102 Series, and a connected-externally encoder expansion card is required for E180 Series.

If the load motor is permanent magnet synchronous motor, the VC shall be selected.

**Note: if the vector control mode is selected, it is better to identify the parameters of the motor, only precise parameters of the motor can give play to the advantages of VC Mode.**

Function code	Function Name	Setting scope	Factory set value
P0.0.03	Option of operation control mode	0: Keyboard Control 1: Terminal Control 2: Communication Control	0

**0: Keyboard Control**

Key RUN, STOP and JOG on operating panel control start, stop and FWD& REV switch of the frequency inverter

**1: Terminal Input**

Use the digital input terminal to control FWD, REV and stop of the frequency inverter

**2: Communication Control**

Use the principal computer to control FWD, REV, stop, jog and reset (Refer to Chapter VIII for more details)

Detailed methods for the above three kinds of control methods refer to 7.1.1

Function code	Function Name	Setting scope	Factory set value
P0.0.04	Option of A Frequency Source	0: Keyboard Reference (No Power-off Memory) 1: Keyboard Reference (Power-off Memory) 2: Keyboard Potentiometer Reference 3: External Terminal VF1 Reference 4: External Terminal VF2 Reference 5: PULS Reference (DI6) 6: Multiplex Directive Reference 7: Simple PLC Reference 8: PID Control Reference 9: Communication Reference 10: Operation Result 1 11: Operation Result 2 12: Operation Result 3 13: Operation Result 4	02

**0: Keyboard Reference (No Power-off Memory)**

The initial value of the reference frequency is the value set by Function Code P0.0.05, and it can be changed through Key▲&▼ on the keyboard or Terminal UP/DOWN, which can be set by Function Code P0.1.05 to save such shut-down change (keyboard reference frequency shut-down memory selection). After the frequency inverter powers on again after power off, the reference frequency is set to value set by P0.0.05.

**1: Keyboard Reference (Power-off Memory)**

The initial value of the reference frequency is the value set by Function Code P0.0.05, and it can be changed through Key▲&▼ on the keyboard or Terminal UP/DOWN, which can be set by Function Code P0.1.05 to save such shut-down change (keyboard reference frequency shut-down memory selection). After the frequency inverter powers on again after power off, the reference frequency is the frequency at the time of power off, and it can be saved through Key▲&▼ on the keyboard or Terminal UP/DOWN.

**2: Keyboard Potentiometer Reference**

The reference frequency is given by the potentiometer on operation panel. The impact of zero-offset or voltage attenuation caused by overlong keyboard lines can be adjusted through Function Code P8.1.00~P8.1.04.

**3: External Terminal VF1 Reference**

4: External Terminal VF2 Reference

The reference frequency is given by the analog input terminal. E Series Frequency inverter provides 2-way analog input terminal (VF1, VF2). VF1 and VF2 can input 0V~10V voltage or 0/4mA~20mA current. As for corresponding relation curve between the input of VF1 and VF2 and the reference frequency, the users can freely choose from four kinds of the relation curves through function code P2.1.02, in which Curve 1 and Curve 2 are linear relationship able to be set through Function Code P2.0.13~P2.0.22, and Curve 3 and Curve 4 are broken line relationship with two inflection points able to be set through Function Code P2.1.04~P2.1.19. The deviation between actual voltage and sampling voltage of the analog input terminal can be adjusted through Function Code P8.1.05~P8.1.12.

5: PULS Reference (DI6)

The frequency reference is given by high-speed impulse frequency of digital input terminal D16 (the terminal function is not defined). The corresponding relationship between high-speed impulse frequency and torque upper limit value can be set through Function Code P2.0.23~P2.0.26, that is, line relationship.

6: Multiplex Directive Terminal Reference

The reference frequency is given by different composite state of Multiplex Directive Terminal. E Series Frequency inverter is able to set four Multiplex Directive Terminals (Terminal Function 9~12, refer to the Description for Multiplex Directive Terminal Function of P2.0.00~P2.0.09 for more details)

7: Simple PLC Reference

The reference frequency is given by Simple PLC Function, the running frequency of the frequency inverter can be switched among 1~16 arbitrary frequency directives, the sources, hold time and acceleration & deceleration time of each frequency directive can be set through Function Code 3.0.03~P3.0.50.

8: PID Control Reference

The reference frequency is given by the frequency calculated from PID Control. When setting the frequency calculated from PID Control, it is required to setting related parameters of “PID Control Group” (P4.0.00~P4.0.20).

9: Communication Reference

The reference frequency is given by the principal computer through communication mode (Refer to Chapter VIII for more details)

10: Operation Result 1

11: Operation Result 2

12: Operation Result 3

13: Operation Result 4

The reference frequency is determined by the operation results after setting calculation of the internal operation module. Refer to the Description of Function Code P3.2.26~P3.2.39 for more details of the operation module. The operation results can be viewed through Function Code 9.0.46~P9.0.49.

Function code	Function name	Setting scope	Factory set value
P0.0.05	Keyboard Frequency Reference	000.00~ maximum frequency	050.00

When the Function Code P0.0.04 or P0.1.01 is set to 0 or 1, the initial value of the reference frequency is given by this function code.

Function code	Function name	Setting scope	Factory set value
P0.0.06	Running Direction	0: Default Direction 1: Negation of Direction 2: Determined by multi-function input terminal	0

The modification on this function code can realize the purpose of changing the motor steering without changing the connection of the motor and its role is equivalent to adjust any two lines of Motor U, V and W to realize the shifting of the steering direction of the motors. This function code is valid in any running control mode. When P0.0.06 is set to 2, the running direction is determined by multi-function input terminal. The function code of multi-function input terminal is 37, and if the terminal signal is valid and the reversed direction is adopted.

**Note: Recover Factory set values, the running direction of the motor can restore to original state. It should be used with caution for occasions that forbid from changing the motor steering after completing the debugging of the system.**

Function code	Function name	Setting scope	Factory set value
P0.0.07	Maximum frequency	050.00Hz~320.00Hz	050.00

The highest frequency refers to the maximum frequency that the frequency inverter allows to output.

When the analog input, PULS Impulse Input, multiplex directive input and simple PLC in E Series Frequency inverter are adopted as frequency source, each percentage is set based on the value given by corresponding function code.

**Note: the modification to this set value can change the data which takes the set value of this function code as calibration.**

Function code	Function name	Setting scope	Factory set value
P0.0.08	Upper frequency	Lower frequency ~ highest frequency	050.00
P0.0.09	Lower frequency	000.00~ Upper frequency	000.00

The upper limit frequency is the Highest Frequency allowed to run set by the users. At P0.1.03=0, the set value of Function Code P0.0.08 determines the Highest Frequency that the frequency inverter allows to run.

The lower limit frequency is the minimum frequency allowed to run set by the users.

The relationship among Highest Frequency, Upper Limit Frequency and Lower Limit Frequency are shown in the figure below:

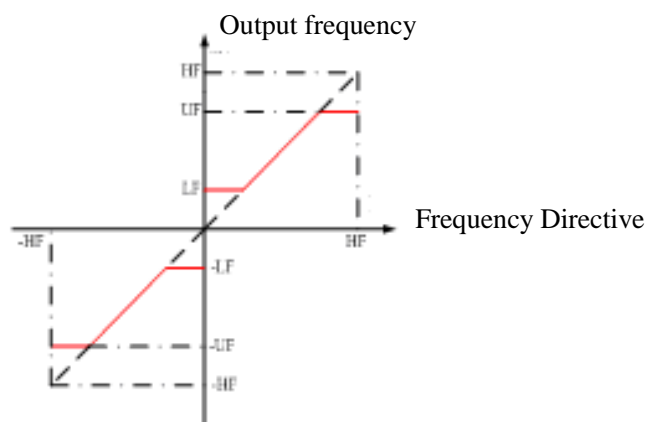

HF: Highest Frequency   UF: Upper Frequency   LF: Lower Frequency

Function code	Function name	Setting scope	Factory set value
P0.0.10	Lower frequency operation mode	0:Running at lower limit frequency 1: Stop 2: Zero-speed Running	0

0: Run at lower limit frequency

When the reference frequency is less than the lower limit frequency (value set by P0.0.09), the frequency inverter runs at lower limit frequency

1: Stop

When the reference frequency is less than the lower limit frequency, the frequency inverter stops

2: Zero-speed Running

When the reference frequency is less than the lower limit frequency, the frequency inverter runs at 0Hz

**Note: when running at 0Hz, the frequency inverter can output a certain voltage, so special attention shall be paid when in use.**

**If no voltage output when inverter runs at 0 Hz, should set function code P0.0.09=000.05, P3.2.00=00002, and P3.2.07=3714.**

Function code	Function name	Setting scope	Factory set value
P0.0.11	Acceleration Time	0000.1s~6500.0s	Machine type
P0.0.12	Deceleration Time	0000.1s~6500.0s	Machine type

The acceleration time refers to time required to raise the frequency inverter from zero frequency to reference frequency of the acceleration and deceleration time (set by Function Code P0.1.07).

The deceleration time refers to time required to reduce the frequency inverter reference frequency of the acceleration and deceleration time to zero frequency.

See the Description of the Figure below:

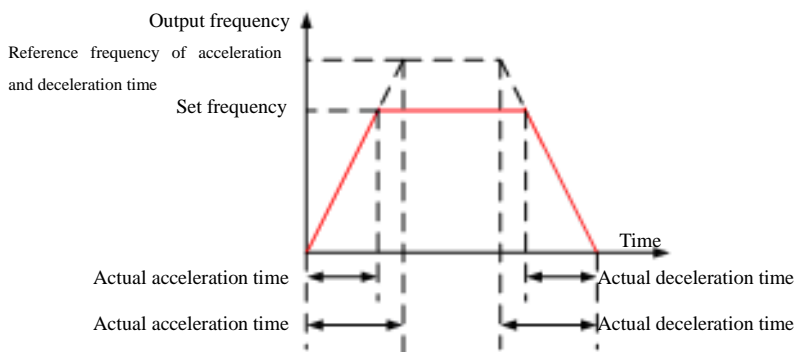

Function code	Function name	Setting scope	Factory set value
P0.0.13	Type of Motor	0:Common motor 1:Variable frequency motor 2: Synchronous Motor (Invalid E100)	0

This function code is used to set the type of the load motor equipped with the frequency inverter.

#### 0: Common motor

Because heat radiation effect of the common motor becomes worse when running at low speed, relative electronic thermal protection value should be adjusted properly; low speed compensating performance of motor protection mode is to lower protection threshold of motor overload when running frequency is less than 30Hz.

#### 1: Variable frequency motor

Variable frequency motor uses forced air cooling, so that radiating effect is not affected by the rotating speed. Hence, it is not required to lower protection threshold when running at low speed.

#### 2: Synchronous Motor

If it is synchronous motor, the control mode is set to closed-loop vector control (i.e. P0.0.02=2). CDI-E100, E102 Series can't support synchronous motor.

Function code	Function Name	Setting scope	Factory set value
P0.0.14	Motor rated power	0000.1kW ~ 1000.0kW	Machine type
P0.0.15	Motor rated frequency	000.01Hz ~ Highest frequency	050.00
P0.0.16	Motor rated voltage	0001V ~ 2000V	Machine type
P0.0.17	Motor rated current	000.01A ~ 655.35A (inverter power < 75kW) 0000.1A ~ 6553.5A (inverter power ≥ 75kW)	Machine type
P0.0.18	Motor Rated Rotating Speed	00001rpm ~ 65535rpm	Machine type
P0.0.19	Stator resistance of asynchronous motor	00.001Ω ~ 65.535Ω (inverter power < 75kW) 0.0001Ω ~ 6.5535Ω (inverter power ≥ 75kW)	Machine type
P0.0.20	Rator resistance of asynchronous motor	00.001Ω ~ 65.535Ω (inverter power < 75kW) 0.0001Ω ~ 6.5535Ω (inverter power ≥ 75kW)	Machine type
P0.0.21	Leakage inductance of asynchronous motor	000.01mH ~ 655.35mH (inverter power < 75kW) 00.001mH ~ 65.535mH (inverter power ≥ 75kW)	Machine type
P0.0.22	Mutual inductance of asynchronous motor	0000.1mH ~ 6553.5mH (inverter power < 75kW) 000.01mH ~ 655.35mH (inverter power ≥ 75kW)	Machine type
P0.0.23	No-load current of asynchronous motor	000.01A ~ Motor rated current (inverter power < 75kW) 0000.1A ~ Motor rated current (inverter power ≥ 75kW)	Machine type

Function code P0.0.14~P0.0.23 are intrinsic parameters of AC asynchronous motor, no matter what is adopted, V/F control or vector control, all have certain requirements to the parameters of the motor, especially for vector control, it requires that value of P0.0.19~P0.0.23 must be very close to the intrinsic parameters of the motor, the more the precision of the value is, the better the performance of the vector control is, therefore, when using the vector control, it is better to identify the motor through Function Code P0.0.24. If the identification cannot be made on site, according to the parameters provided by the motor manufacturer, it is to input them into the above corresponding function code.

Function code	Function name	Setting scope	Factory set value
P0.0.24	Parameter Identification Control	00: No action 01: Static identification 02: Complete identification 11: Synchronous machine on-load identification (Invalid E100) 12: Synchronous machine non-load identification (Invalid E100)	00

Refer to 7.1.20 for more details (Parameter Identification)

**P0.1: Expansion Group**

Function code	Function Name	Setting scope	Factory set value
P0.1.00	Option of Frequency Source	0: Frequency Source A 1: Frequency Source B 2: Frequency Source A+B 3: Frequency Source A-B 4: Max. Value of A & B 5: Min. Value of A & B 6: Standby Frequency Source 1 7: Standby Frequency Source 2 8: Switch of Terminal among the above 8 kinds	0

**0: Frequency Source A**

The reference frequency is given by Frequency Source A (P0.0.04).

**1: Frequency Source B**

The reference frequency is given by Frequency Source B (P0.1.01).

**2: Frequency Source A+B**

The reference frequency is given by Frequency Source A+B.

**3: Frequency Source A-B**

The reference frequency is given by A-B Frequency, if A-B Frequency is negative value; the frequency inverter runs in opposite direction

**4: Max. Value of A & B**

The reference frequency is determined by the maximum value between Frequency Source A and B.

**5: Min. Value of A & B**

The reference frequency is determined by the minimum value between Frequency Source A and B.

**6: Standby Frequency Source 1**

**7: Standby Frequency Source 2**

Standby Frequency Source 1 and Standby Frequency Source 2 are reserved by the manufacturer as frequency sources used for special occasions in future, so the users may ignore them as usual.

**8: Switch of Terminal among the above 8 kinds**

The reference frequency is switched among the above 8 kinds of frequency sources by selecting different composite state of the terminals. E Series Frequency inverter can set 3 kinds of frequency sources to choose the terminals (Terminal Function 18~20, refer to the instruction for Terminal Selection Function of Frequency Source P2.0.00~P2.0.09 for more details)

Function code	Function Name	Setting scope	Factory set value
P0.1.01	Option of Frequency Source B	0:Keyboard Reference (No Power-off Memory) 1:Keyboard Reference (Power-off Memory) 2:Keyboard Potentiometer Reference 3: External Terminal VF1 Reference 4:External Terminal VF2 Reference 5:PULS Reference (DI6) 6: Multiplex Directive Reference 7:Simple PLC Reference 8:PID Control Reference 9:Communication Reference 10:Operation Result 1 11:Operation Result 2 12:Operation Result 3 13:Operation Result 4	00

This function case has the same function with “Option of Frequency Source A” (P0.0.04), if it is needed to use, please refer to the setting method for Function Code P0.0.04 to set.

Function code	Function name	Setting scope	Factory set value
P0.1.02	Adjustment Volume of: Frequency Source B at superposition	000%~150%	100

When the reference frequency of frequency inverter is given by Frequency Source A+B and Frequency Source A-B, it defaults A to main reference and B to auxiliary Reference. This function code determines the regulation size of Frequency Source B, which is the percentage relative to the scope of Frequency Source B (set by Function Code P0.2.01)

At P0.2.01=0, the frequency of Frequency Source B is regulated relative to Highest Frequency.

At P0.2.01=1, the frequency of Frequency Source B is regulated relative to frequency of Frequency Source A.

Function code	Function name	Setting scope	Factory set value
P0.1.03	Upper Limit Frequency Source	0: Digital Reference (P0.0.08) 1: External Terminal VF1 Reference 2: External Terminal VF2 Reference 3: Multiplex Directive Reference 4: PULS Reference (DI6) 5: Communication Reference 6: Operation Result 1 7: Operation Result 2 8: Operation Result 3 9: Operation Result 4	0

This function code determines the source of the upper limit frequency.

0: Digital Reference (P0.0.08)

The upper limit frequency is determined by the value set by Function Code P0.0.08.

1: External Terminal VF1 Reference

2: External Terminal VF2 Reference

The upper limit frequency is given by the analog input terminal. E Series Frequency inverter provides 2-way analog input terminal (VF1, VF2). VF1 and VF2 can input 0V~10V voltage or 0/4mA~20mA current. As for corresponding relation curve of the input of VF1 and VF2 and the upper limit frequency, the users can freely choose from four kinds of the relation curves through function code P2.1.02, in which Curve 1 and Curve 2 are

## Chapter 6. Description of Parameters

linear relationship able to be set through Function Code P2.0.13~P2.0.22, and Curve 3 and Curve 4 are broken line relationship with two inflection points able to be set through Function Code P2.1.04~P2.1.19. The deviation between actual voltage and sampling voltage of the analog input terminal can be adjusted through Function Code P8.1.05~P8.1.12.

### 3: Multiplex Directive Terminal Reference

The upper limit frequency is set by different composite state of Multiplex Directive Terminal. E Series Frequency inverter is able to set four Multiplex Directive Terminals (Terminal Function 9~12, refer to the Description for Multiplex Directive Terminal Function of P2.0.00~P2.0.09 for more details)

### 4: PULS Reference

The upper limit frequency is set by high-speed impulse frequency of digital input terminal D16 (the terminal function is not defined). The corresponding relationship between high-speed impulse frequency and upper limit frequency can be set through Function Code P2.0.23~P2.0.26, that is, linear relationship.

### 5: Communication Reference

The upper limit frequency is set by the upper computer through communication mode (refer to Chapter VIII for more details).

### 6: Operation Result 1

### 7: Operation Result 2

### 8: Operation Result 3

### 9: Operation Result 4

The upper limit frequency is determined by data after setting calculation of the internal operation module. Refer to the Description of Function Code P3.2.26~P3.2.39 for more details of the operation module. The operation results can be viewed through Function Code 9.0.46~P9.0.49.

**Note: the upper limit frequency cannot be set to negative value, but if it is the negative value, the upper limit frequency is invalid.**

Function code	Function name	Setting scope	Factory set value
P0.1.04	Upper Limit Frequency Offset	000.00~Highest Frequency	000.00

The set value of this function code is the offset of the upper frequency, and the superposition of this offset and upper frequency set by Function Code P0.1.03 is adopted as final set value of upper frequency.

Function code	Function name	Setting scope	Factory set value
P0.1.05	Keyboard Reference frequency Shut-down Memory Selection	0: No Memory 1: Memory	0

#### 0: No Memory

After the frequency inverter stops, the reference frequency is recover the value given by Function Code P0.0.05, and the frequency allowance, which is conducted through Key▲&▼ on the keyboard or Terminal UP/DOWN, is cleared .

#### 1: Memory

After the frequency inverter stops, the reference frequency is the frequency set before stop, and the frequency allowance, which is conducted through Key▲&▼ on the keyboard or Terminal UP/DOWN, is saved.

**Note: this function code is valid only when the frequency source is set by the keyboard.**

Function code	Function name	Setting scope	Factory set value
P0.1.06	Keyboard Reference frequency Action Benchmark at running	0: Running Frequency 1: Reference frequency	0

When this function code is adopted to determine the action of Key ▲ & ▼ on the keyboard or Terminal UP/DOWN, it is to confirm what a kind of mode is adopted to correct the frequency and the increase & decrease shall be done on the basis of running frequency or reference frequency .

0: Running Frequency

The regulation shall be made on the basis of running frequency

1: Reference frequency

The regulation shall be made on the basis of reference frequency

The difference between two settings is obvious when the frequency inverter is in the process of acceleration and deceleration, namely, when the running frequency differs from the reference frequency, different Option of parameters leads to great difference.

**Note: this function code is valid only when the frequency source is set by the keyboard.**

Function code	Function name	Setting scope	Factory set value
P0.1.07	Benchmark frequency of accelerating and Deceleration time	0: Highest Frequency 1: Reference frequency 2: 100Hz	0

0: Highest Frequency

The acceleration and deceleration time refers to the time from frequency 0 to highest frequency, and it can change with the change of the highest frequency at this time.

1: Reference frequency

The acceleration and deceleration time refers to the time from frequency 0 to highest frequency, and it can change with the change of the reference frequency at this time.

2: 100Hz

The acceleration and deceleration time refers to the time from frequency 0 to 100Hz, and it is a fixed value at this time.

**Note: the jogging acceleration and deceleration time is also subject to its control.**

Function code	Function name	Setting scope	Factory set value
P0.1.08	Jogging running frequency	000.00~Highest Frequency	002.00
P0.1.09	Jogging Acceleration time	0000.0s~6500.0s	0020.0
P0.1.10	Jogging Deceleration time	0000.0s~6500.0s	0020.0

The function codes above define the reference frequency and acceleration and deceleration time when the frequency inverter is at jogging running.

Function code	Function name	Setting scope	Factory set value
P0.1.11	Acceleration time 2	0000.0s~6500.0s	Machine type
P0.1.12	Deceleration time 2	0000.0s~6500.0s	Machine type
P0.1.13	Acceleration time 3	0000.0s~6500.0s	Machine type
P0.1.14	Deceleration time 3	0000.0s~6500.0s	Machine type
P0.1.15	Acceleration time 4	0000.0s~6500.0s	Machine type
P0.1.16	Deceleration time 4	0000.0s~6500.0s	Machine type

The function codes above have the same definitions with P0.0.11 and P0.0.12; refer to the Description of P0.0.11 and P0.0.12 for more details

E Series Frequency inverter totally provides 4 groups of acceleration and deceleration time of the straight line, which can switch among 4 groups of acceleration and deceleration time through different composite state of acceleration and deceleration time selection terminals. It can set 2 acceleration and deceleration time selection

Chapter 6. Description of Parameters

terminals (terminal function 16~17, refer to the Description of Code P2.0.00~P2.0.09 for Acceleration and Deceleration Time Selection Terminal Function of Function for more details)

Function code	Function name	Setting scope	Factory set value
P0.1.17	Frequency Switch Point between Acceleration time 1 and Acceleration time 2	000.00Hz~Highest Frequency	000.00
P0.1.18	Frequency Switch Point between Deceleration time 1 and Deceleration time 2	000.00Hz~Highest Frequency	000.00

The function codes above are adopted to set the frequency of the switch point of acceleration and deceleration time 1 and acceleration and deceleration time 2. When the running frequency of the frequency inverter is less than the set value of these two function codes, the acceleration and deceleration time 2 is adopted, otherwise the acceleration and deceleration time 1 is adopted.

**Note: when using this function, the acceleration and deceleration time 1 and acceleration and deceleration time 2 cannot be set to 0s.**

Function code	Function name	Setting scope	Factory set value
P0.1.19	Acceleration and Deceleration Mode	0: Straight Line 1: Curve S 1 2: Curve S 2	0

0: Acceleration and Deceleration of the Straight Line

The output frequency increases or decreases by the straight line. E Series Frequency inverter provides 4 groups of acceleration and deceleration time of the straight line, namely, P0.0.11 and P0.0.12, P0.1.11 and P0.1.12, P0.1.13 and P0.1.14 and P0.1.15 and P0.1.16. The switch can be selected through different composite state of acceleration and deceleration time selection terminals.

1: Curve S 1

The output frequency increases or decreases by Curve S 1. Curve S 1 is used for occasions required for gradual start or stop. Parameter P0.1.20 and P0.1.21 respectively defines the time scale of starting point and ending point of Curve S 1.

2: Curve S 2

In the Curve S 2, the rated frequency of the motor is always the inflection point of Curve S, as shown in the figure below. Generally, it applies for the occasions that the high-speed area above the rated frequency requires to rapidly accelerate and decelerate.

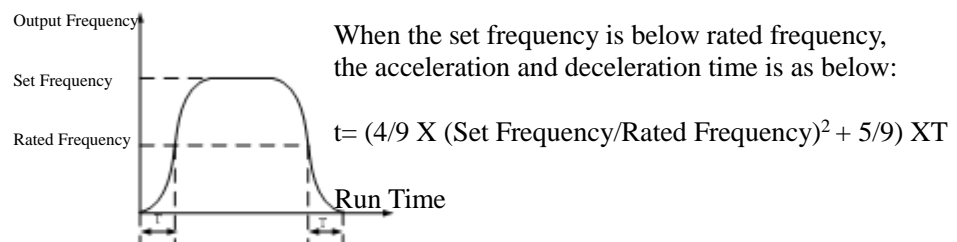

Function code	Function name	Setting scope	Factory set value
P0.1.20	Percentage of Starting Phase of Curve S	000.0%~100.0%	030.0
P0.1.21	Percentage of Ending Phase of Curve S	000.0%~100.0%	030.0

Parameter P0.1.20 and P0.1.21 respectively defines the time scale of starting point and ending point of Curve S 1. These two parameters need to meet  $P0.1.20 + P0.1.21 \leq 100.0\%$ , refer to the Description for the figure below:

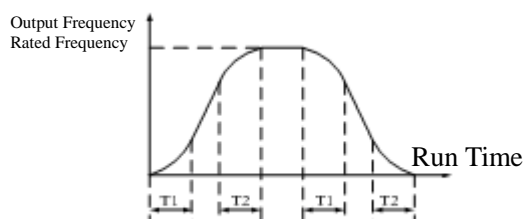

T1 is the value set by Function Code P0.1.20, the slope of the output frequency gradually increases from zero within this period of time.

T2 is the value set by Function Code P0.1.21, the slope of the output frequency gradually decreases to zero within this period of time.

Within the time between T1 and T2, the change on slope of the output frequency keeps constant.

Function code	Function name	Setting scope	Factory set value
P0.1.22	Hopping Frequency 1	000.00Hz~Highest Frequency	000.00
P0.1.23	Hopping Frequency 2	000.00Hz~Highest Frequency	000.00
P0.1.24	Hopping Frequency scope	000.00Hz~Highest Frequency	000.00

The hopping frequency function is set so that running frequency of the frequency inverter can avoid load resonance band of the driving system. E Series Frequency inverter can set two hopping frequency points, after setting, even the reference frequency is within load resonance band, the output frequency of the frequency inverter will also be automatically adjusted out of load resonance band to avoid running on resonant frequency, refer to the Description for the figure below:

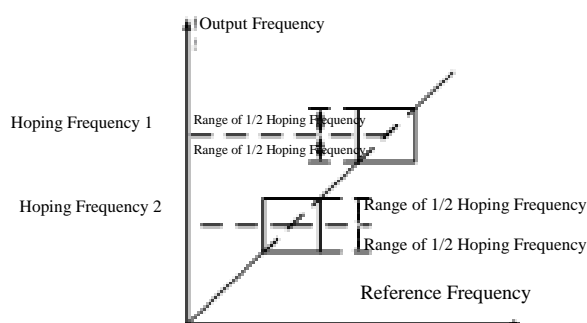

Function Code	Function name	Setting Scope	Factory set value
P0.1.25	Jogging Priority	0:Invalid 1:Valid	0

This function code is used to set whether the priority of the jogging function is the highest. The jogging function includes Keyboard Jogging Function and Terminal Jogging Function.

When at P0.1.25=1, if the jogging command occurs in the running process, the switch of frequency inverter is the jogging running state. The target frequency is the jogging frequency and the acceleration and deceleration time is the jogging acceleration and deceleration time.

Function code	Function name	Setting scope	Factory set value
P0.1.26	Type of Encoder	0: ABZ Incremental Encoder 1: UVW Incremental Encoder (E100 Invalid) 2: Rotary Transformer (E100Invalid) 3~9: Reservation 10: Distance Control (Open Collector)	0

This function code is used to set the selected type of the Encoder.

CDI-E180 Series Frequency inverter supports various types of the encoders. Different encoder needs to configure different encoder expansion card, when in use, the correct encoder expansion card shall be selected and ordered. The synchronous motor may select any one of three types of the encoders in the table above, while the asynchronous motor generally selects and uses ABZ incremental encoder and rotary transformer.

## Chapter 6. Description of Parameters

After completing the installation of the encoder, the value of Function Code P0.1.27 shall be correctly set based on actual conditions, or the frequency inverter may not run normally.

**Note: when the open collector-type encoder is adopted to realize the distance control, the function code must be set to P0.1.26=10.**

Function code	Function name	Setting scope	Factory set value
P0.1.27	Line Number of Encoder	00001~65535	01024

This function code is used for the number of pulses per revolution to set ABZ or UVW incremental encoder.

In closed-type vector control mode, the line number of the encoder must be correctly set, or the frequency inverter will not run normally.

Function code	Function name	Setting scope	Factory set value
P0.1.28	ABZ phase sequence	0: Forward Direction 1: Reverse Direction	0

This function code is only valid for ABZ incremental encoder, namely, it is valid at P0.1.26=0, and used to set the phase sequence of ABZ Incremental Encoder AB Signal. It is valid for synchronous motor and asynchronous motor, when the asynchronous motor is completely tuned or the synchronous motor is tuned, the AB Phase Sequence is acquired for ABZ Encoder.

Function code	Function Name	Setting scope	Factory set value
P0.1.29	Encoder Disconnection Testing Time	00: No action 00.1s~10.0s	00.0

When the test time of the encoder disconnection fault is set to 00.0, the frequency inverter can't detect the disconnection fault of encoder. When the frequency inverter has been detected with disconnection fault and the duration is over the time set by Function Code P0.1.29, then the frequency inverter gives an alarm of Fault Err25.

Function code	Function Name	Setting scope	Factory set value
P0.1.30	Stator resistance of synchronous motor	00.001 $\Omega$ ~ 65.535 $\Omega$ (inverter power < 75kW) 0.0001 $\Omega$ ~ 6.5535 $\Omega$ (inverter power $\geq$ 75kW)	Machine type
P0.1.31	Back EMF of Synchronous motor	0000.0V ~ 6553.5V	Machine type

The above parameters are intrinsic parameters of synchronous motor, the load motor equipped with the frequency inverter refers to synchronous motor, it requires that value of P0.1.30~P0.1.31 must be very close to the intrinsic parameters of the motor, the more the precision of the value is, the better the performance of the vector control is. The motor parameters are identified through Function Code P0.0.24. If the identification cannot be made on site, according to the parameters provided by the motor manufacturer, it is to input them into the above corresponding function code.

Function code	Function Name	Setting scope	Factory set value
P0.1.32	UVW Phase Sequence	0: Forward Direction 1: Reverse Direction	Machine type
P0.1.33	UVW Encoder Angle	000.0~359.9	Machine type

The above function codes are only valid when the synchronous motor adopts UVW incremental encoder.

These two parameters are more important for the running of the synchronous motor, so it is better to acquire these two parameters of the synchronous motor through identification by Function Code P0.0.24 after completing initial installation.

Function code	Function name	Setting scope	Factory set value
P0.1.34	Pole-pairs of Rotary Transformer	00001~65535	Machine type

When the encoder is rotary transformer (i.e. P0.1.26=2), this function code is used to set its pole-pairs.

## 6.2 Group P1 - Motor Control Parameter

### Group P1.0 - Basic Group

Function code	Function name	Setting scope	Factory set value
P1.0.00	V/F Curve Mode	0: Straight Line 1: Multi-point Broken Line 2: Square V/F Curve 1 3: Square V/F Curve 2 4: Square V/F Curve 3	0

#### 0: Straight Line V/F

Applicable for common constant torque load

#### 1: Multi-point Broken Line

V/F Relation Curve of any broken lines can be acquired through setting Function Code P1.1.00 ~ P1.1.05.

#### 2: Square V/F

Applicable for centrifugal loads of fans, water pumps, etc.

#### 3: Square V/F Curve 2

#### 4: Square V/F Curve 3

Refer to relation curve between straight line V/F and square V/F

Each curve is shown in the figure below:

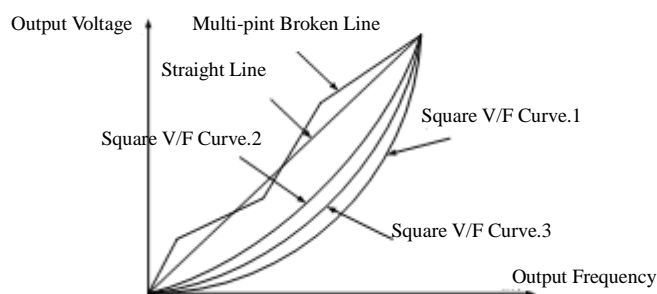

Function code	Function name	Setting scope	Factory set value
P1.0.01	Torque Boost	00.0% (Automatic Torque Boost) 00.1%~30.0%	04.0
P1.0.02	Cutoff Frequency of Torque Boost	000.00Hz~Highest Frequency	050.00

In order to compensate the property of controlling the lower frequency torque by V/F, the boosting compensation is conducted for output voltage in low-frequency working area. Under normal circumstances, the factory set value can meet the requirements, if the compensation is too great, the current fault may occur. When the load is heavier and the low-frequency torque of the motor is not enough, it suggests increasing this parameter. When the load is lighter, this parameter can be reduced.

The frequency inverter is automatic torque boost when the torque boost is set at 00.0%, the frequency inverter can automatically calculate the required torque boost value based on the parameters of the motor as stator, resistance, etc.

**Torque Boost Cut-off Frequency:** when the output frequency is below this set value, the torque boost is valid, in case of exceeding this set value, the torque boost is invalid

Function code	Function name	Setting scope	Factory set value
P1.0.03	V/F Slip Compensation Gain	000.0%~200.0%	000.0

This function code is only valid for asynchronous motor and the percentage relative to rated slip of motor. When it is the slip that is compensated by the motor for rated load, the rated slip of the motor can be calculated and acquired based on rated frequency of the motor and rated speed. V/F Slip Compensation can compensate asynchronous motor for the speed deviation of the motor occurred from load increase so as to make the speed able to basically keep stable.

Function code	Function name	Setting scope	Factory set value
P1.0.04	Velocity Loop Proportional Gain 1	001~100	030
P1.0.05	Velocity Circulation Integral Time 1	00.01~10.00	00.50
P1.0.06	Switching Frequency 1	000.00Hz~P1.0.09	005.00
P1.0.07	Velocity Loop Proportional Gain 2	001~100	020
P1.0.08	Velocity Circulation Integral Time 2	00.01~10.00	01.00
P1.0.09	Switching Frequency 2	P1.0.06~Highest Frequency	010.00

The above parameters can realize that the frequency inverter may select the parameters of different Velocity Loop PI at different running frequency. When the running frequency is less than the switch frequency 1(P1.0.06), the parameters of Velocity Loop PI are adjusted to P1.0.04 and P1.0.05.

When the running frequency is greater that the switch frequency 2 (P1.0.09), the parameters of Velocity Loop are P1.0.07 and P1.0.08.

The parameters of Velocity Loop PI between switch frequency 1 and switch frequency 2 are the linear switch of two groups of PI parameters.

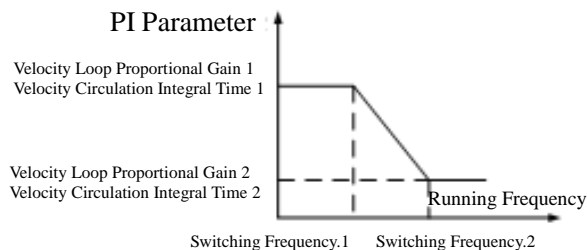

The increase of proportional gain P can speed up the dynamic response of the system, but if P is too great, it may easily vibrate. The decrease of integration time I can speed up the dynamic response of the system, but if I is too small, it may have large overshoot and easily vibrate. Generally, the proportional gain P is first adjusted so as to increase P as possible under the preconditions of ensuring non-vibration of the system, and then it is to adjust the integration time I to make the system not only have rapid response property, but small overshoot.

Function code	Function name	Setting scope	Factory set value
P1.0.10	Start Mode	0: Direct Start 1: Speed Tracking Mode 2: Brake and Restart	0

**0: Direct Start**

The frequency inverter starts running from start frequency.

**1: Rotating Speed before Start**

The frequency inverter shall first judge the rotating speed and direction of the motor and then track down the start frequency of motor, the rotating motor smoothly starts without any surge. It is applicable for momentary interruption restart of the high inertia loads. In order to ensure the performance of rotating speed before start, accurate setting of the motor parameters is required.

**2: Brake before Start**

First conduct DC braking and them start running from start frequency.

Function code	Function name	Setting scope	Factory set value
P1.0.11	Speed Tracking Mode	0: Start from Shutdown Frequency 1: Start from Zero Speed 2: Start from Highest Frequency	0

0: Start from Stop Frequency

Track down from the frequency at the moment of stop and adopt this method as usual.

1: Start from Zero Speed

Track up from zero frequency and adopt this method when start after longer stop time.

2: Start from Highest Frequency

Track down from highest frequency

**Note: this function code is only valid when the start mode is speed tracking start (i.e. P1.0.10=1)**

Function code	Function name	Setting scope	Factory set value
P1.0.12	Start Frequency	00.00Hz~10.00Hz	00.00
P1.0.13	Hold Time of Start Frequency	000.0s~100.0s	000.0

Start Frequency: refer to running frequency when the frequency inverter starts.

In order to ensure that the motor has a certain start torque, proper start frequency shall be given. If the setting is too great, the overcurrent may occur. When the reference frequency is less than start frequency, the frequency inverter cannot start and is at ready mode (when jogging, it is not subject to the impact of start frequency).

Hold Time of Start Frequency: refer to the running time of starting the frequency during the process of start.

Function code	Function name	Setting scope	Factory set value
P1.0.14	Starting DC Brake Current	000%~100%	000
P1.0.15	Starting DC Brake Time	000.0s~100.0s	000.0

Starting DC Brake Current: refer to the output current in the process of starting DC brake, which is the percentage relative to rated current of the motor, the larger the starting DC brake current, the greater the braking force is.

Starting DC Brake Time: refer to duration time of outputting the start DC brake current in the process of starting the frequency inverter.

Function code	Function name	Setting scope	Factory set value
P1.0.16	Shutdown mode	0: Reducing speed to shut down 1: Shut down freely	0

0: Stop by Speed Deceleration

After the stop command is effective, the frequency inverter reduces the output frequency based on deceleration time and stops after the frequency is reduced to 0.

1: Free Stop

After the stop command is effective, the frequency inverter immediately stops outputting and the motor stops freely based on mechanical inertia at this time.

Function code	Function name	Setting scope	Factory set value
P1.0.17	Stop DC Braking Initial Frequency	000.00Hz~Highest Frequency	000.00
P1.0.18	Stop DC Braking Waiting Time	000.0s~100.0s	000.0
P1.0.19	Stop DC Braking Current	000%~100%	000
P1.0.20	Stop DC Braking Time	000.0s~100.0s	000.0

When the output frequency is reduced to the frequency set by P1.0.17 in the stopping process by reducing the speed, after Stop DC Braking Waiting Time set by P1.0.18, it starts to output braking current set by P1.0.19 and conduct DC brake process, until satisfy DC brake time set by P1.0.20 and the inverter stops DC brake.

Properly set Stop DC Braking Waiting Time (P1.0.18) to prevent the faults as overcurrent arising from start DC brake at higher speed. Stop DC Braking Current (P1.0.19) refers to the percentage relative to rated current of the motor. The higher the stop DC braking current is, the larger the brake force is. When Stop DC Braking Waiting Time is set at 000.0, the stop DC brake function is invalid.

Note: P1.0.17 and P1.0.18 also have climbing function. It can improve the instability of braking. During the process of braking, after reducing speed to the frequency set by P1.0.17 and pausing the time set by P1.0.18, deceleration continues until braking. Generally, P1.0.17 is set as 0.05Hz and P1.0.18 is set as 0.1s.

Function code	Function name	Setting scope	Factory set value
P1.0.21	Braking Use Rate	000%~100%	100

This function code is only valid for the frequency inverter of the built-in brake unit. CDI-E100, E102 Series has complete built-in brake units, but CDI-E180 Series 15Kw and below has built-in brake units. but it is option configuration for E180 Series 18.5~30kW.

As for duty ratio of adjusting the brake units, the higher the brake usage rate is, the higher the duty ratio of the brake unit action is and the stronger the brake effect is, but the Bus line voltage fluctuation of the frequency inverter is greater in the brake process.

Function code	Function name	Setting scope	Factory set value
P1.0.22	Carrier Frequency	0.50kHz~16.0kHz	06.0

This function code is used to regulate the carrier frequency of the frequency inverter. The regulation of the carrier frequency can lower the noise of the motor and reduce the line-to-ground leakage current and the interference arising from the frequency inverter. When the carrier frequency is lower, the high-order harmonic components of output current increase, the losses of motor increase and the temperature of the motor rises. When the carrier frequency is higher, the losses of motor are reduced and the temperature rise of the motor decreases, but the losses of the frequency inverter increase and the temperature of the frequency inverter rise, so the interference is enhanced.

The regulation of the carrier frequency can influence the following performance:

Carrier Frequency	Low → High
Noise of Motor	Large → Small
Output Current Waveform	Bad → Good
Temperature Rise of Motor	High → Low
Temperature Rise of Frequency inverter	Low → High
Current Leakage	Small → Large
External Radiation Interference	Small → Large

Function code	Function name	Setting scope	Factory set value
P1.0.23	Fan Control	0: Rotate at running 1: Continuous Running 2: Control based on Temperature	0

Refer to action mode used for selecting the cooling fan.

When at P1.0.23=0, the fans of the frequency inverter run at running state and can't run at stop state.

When at P1.0.23=1, the fans keep running after power on.

When at P1.0.23=2, the fans run when the temperature of the radiator is higher than 35°C, but can't run when lower than 35°C.

Function code	Function name	Setting scope	Factory set value
P1.0.24	Motor Overload Protection	0: Prohibition 1 :Curve 1 2 :Curve 2 3 :Curve 3	1
P1.0.25	Motor Overload Protection Level	00.20~10.00	01.00
P1.0.26	Motor Overload Alarm System	050%~100%	080

When at P1.0.24=0, the frequency inverter hasn't had overload protection function to the motor, it suggests heating the relay between frequency inverter and motor.

When at P1.0.24=1,2 or 3, the frequency inverter shall judge whether the motor is overload or not based on inverse-time characteristic curve of the overload protection of the motor.

The users need to correctly set the value of P1.0.25 based on actual overload capability and load conditions of the motor, if the set value is too small, it is easy to report the motor overload fault (Err10), while the set value is too large, the motor may have the risk of being burnt, especially for the conditions that the rated current of the frequency inverter is larger than the rated current of the motor. When at P1.0.25=01.00, it means that the motor overload protection level is 100% rated current of the motor.

Function Code P1.0.26 is used to define when the early alarm is given before overload fault protection of the motor. The larger the value is, the smaller the early alarm lead is. When the accumulative output current of the frequency inverter is larger than product of multiplying overload inverse time curve by P1.0.26, the multi-functional output terminal of the frequency inverter outputs Signal ON, and the corresponding multi-functional output terminal is overload pre-alarm of the motor (6).

The overload inverse-time characteristic curve of E Series Frequency inverter is shown in the figure below:

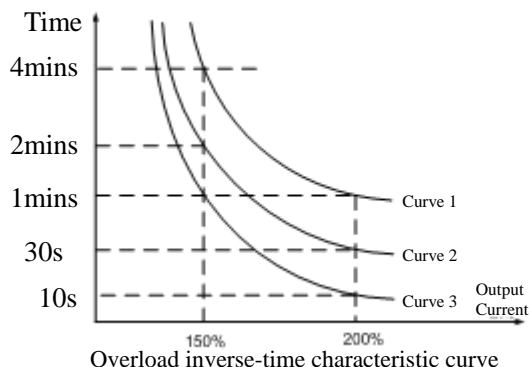

#### Group P1.1 - Expansion Group

Function code	Function name	Setting scope	Factory set value
P1.1.00	Broken Line V/F Point 1 Frequency	000.00Hz~P1.1.02	000.00
P1.1.01	Broken Line V/F Point 1 Voltage	000.0%~100.0%	000.0
P1.1.02	Broken Line V/F Point 2 Frequency	P1.1.00~P1.1.04	000.00
P1.1.03	Broken Line V/F Point 2 Voltage	000.0%~100.0%	000.0
P1.1.04	Broken Line V/F Point 3 Frequency	P1.1.02~Motor rated frequency	000.00
P1.1.05	Broken Line V/F Point 3 Voltage	000.0%~100.0%	000.0

The above functions define V/F Curve with multi-point broken line, and the voltage of the above broken points is the percentage relative to the rated voltage of the motor. V/F Curve with multi-point broken line is given based on the load characteristics of the motor, but attention shall be paid that the relationship between three voltage points and frequency points must meet: P1.1.00<P1.1.02<P1.1.04, P1.1.01<P1.1.03<P1.1.05, refer to the Description in the figure below:

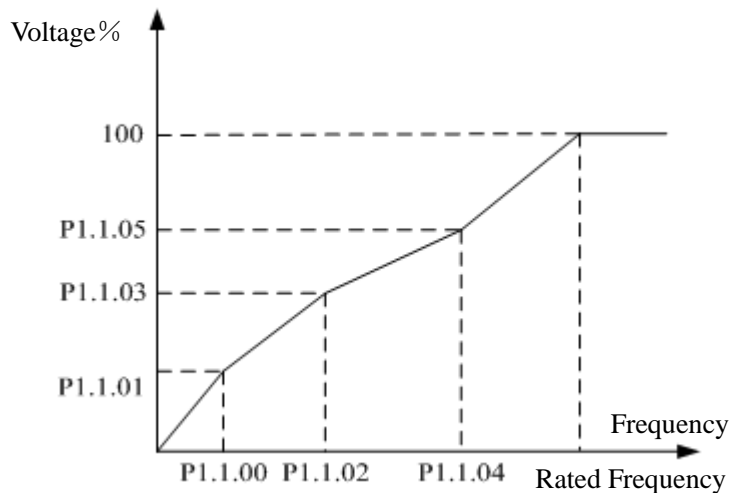

**Note: the voltage cannot be set too large when at low frequency, or the frequency inverter may have overcurrent fault or its motor may be burnt.**

Function code	Function name	Setting scope	Factory set value
P1.1.06	V/F Overexcited Gain	000~200	064

In the deceleration process of the frequency inverter, the pumping voltage can make DC Bus line voltage rise, the overexcited control can restrain the rise of DC Bus line voltage to avoid occurrence of overvoltage fault. The larger the overexcited gain is, the stronger the restraint effect is, but if the overexcited gain is too large, it is easy to lead to increase of the output current, even overcurrent fault. As for the occasions where the rise of DC Bus line voltage is not great or have brake resistance, it suggests setting the overexcited gain at 0.

**Note: this function code is only valid when the control mode is V/F Control (i.e. P0.0.02=0).**

Function code	Function name	Setting scope	Factory set value
P1.1.07	Vector Control Upper Torque Frequency	0: Digital Reference (P1.1.08) 1: External Terminal VF1 Reference 2: External Terminal VF2 Reference 3: Multiplex Directive Terminal Reference 4: PULS Reference (DI6) 5: Communication Reference 6: MIN (VF1, VF2) 7: MAX (VF1, VF2) 8: Operation Result 1 9: Operation Result 2 10: Standby Torque Source 3 11: Standby Torque Source 4	0

0: Digital Reference (P1.1.08)

The upper limit of the vector control torque is given by the value at based on Function Code P1.1.08.

1: External Terminal VF1 Reference

2: External Terminal VF2 Reference

The vector control torque is given by the analog input terminal. E Series Frequency inverter provides 2-way analog input terminal (VF1, VF2). VF1 and VF2 can input 0V~10V voltage or 0/4mA~20mA current. As for corresponding relation curve between the input of VF1 and VF2 and the upper limit of torque, the users can freely choose from four kinds of the relation curves through function code P2.1.02, in which Curve 1 and Curve 2 are linear relationship able to be set through Function Code P2.0.13~P2.0.22, and Curve 3 and Curve 4 are broken line relationship with two inflection points able to be set through Function Code P2.1.04~P2.1.19. The deviation between actual voltage and sampling voltage of the analog input terminal can be adjusted through Function Code P8.1.05~P8.1.12.

**3: Multiplex Directive Terminal Reference**

The vector control is given by different composite state of Multiplex Directive Terminal. E Series Frequency inverter is able to set four Multiplex Directive Terminals (Terminal Function 9~12, refer to the Description for Multiplex Directive Terminal Function of P2.0.00~P2.0.09 for more details)

**4: PULS Reference (DI6)**

The vector control is set by high-speed impulse frequency of digital input terminal D16 (the terminal function is not defined). The corresponding relationship between high-speed impulse frequency and torque upper limit value can be set through Function Code P2.0.23~P2.0.26, that is, linear relationship.

**5: Communication Reference**

The upper limit of vector control torque is set by the upper computer through communication mode (refer to Chapter VIII for more details).

**6: MIN (VF1, VF2)**

The upper limit of vector control torque is set by the input value of VF1 and VF2, whichever is lower.

**7: MAX (VF1, VF2)**

The upper limit of vector control torque is set by the input value of VF1 and VF2, whichever is larger.

**8: Operation Result 1****9: Operation Result 2****10: Operation Result 3****11: Operation Result 4**

The reference frequency is determined by the operation results after setting calculation of the internal operation module. Refer to the Description of Function Code P3.2.26~P3.2.39 for more details of the operation module. The operation results can be viewed through Function Code 9.0.46~P9.0.49.

**Note: when the upper limit of the vector control torque is set by VF1 & VF2, multiplex directive, PULSE, communication and operation results, the corresponding range is the value set by P1.1.08.**

Function code	Function name	Setting scope	Factory set value
P1.1.08	Torque Upper Limit Reference	000.0%~200%	150.0

When at P1.1.07=0, the set value of this function code determines the upper limit of the vector control torque, which is the percentage relative to the rated torque of the motor.

Function code	Function name	Setting scope	Factory set value
P1.1.09	Inversion Control Enable	0: Allow      1: Prohibit	0

This function code is used to set whether the frequency inverter is allowed to run at reverse state.

When at P1.1.09=0, the frequency inverter is allowed to run at reversal state.

When at P1.1.09=1, the frequency inverter is prohibited to run at reversal state, which is mainly used for the occasions that the load is unable to reverse.

**Note: the director of this function code is defined by the set value relative to running direction (P0.0.06)**

Function code	Function name	Setting scope	Factory set value
P1.1.10	Forward and Reverse Dead Time	0000.0s~3000.0s	0000.0

This function code is used to set the duration time of outputting OHZ when the frequency inverter is in the process of forward and reverse switch

Function code	Function name	Setting scope	Factory set value
P1.1.11	Power-on Running Selection	0: Running      1: Not Running	0

This function code is used to set when the frequency inverter runs in response to valid running command at the moment of power-on.

When at P1.1.11=0, the frequency inverter directly responds to the running

When at P1.1.11=1, frequency inverter can't respond to the running. It cannot run until the running command is valid again after it is cancelled.

Function code	Function name	Setting scope	Factory set value
P1.1.12	Droop Control	00.00Hz~10.00Hz	00.00

When more than one motor drive the same load, the uneven distribution of the load may occur. The droop control decreases the output frequency along the increase of the load so as to realize even load of more than one motor. The set value of this function code is the frequency value declined at rated load.

Function code	Function name	Setting scope	Factory set value
P1.1.13	Speed/Torque Control Mode Selection	0: Speed Control 1: Torque Control	0

This function code is used to set what kind of running mode of the frequency inverter is adopted, speed control mode or torque control mode.

When at P1.1.13=0, the speed control mode is adopted

When at P1.1.13=1, the torque control mode is adopted

Function code	Function name	Setting scope	Factory set value
P1.1.14	Torque Reference Source	0: Digital Reference (P1.1.15) 1: External Terminal VF1 Reference 2: External Terminal VF2 Reference 3: Multiplex Directive Terminal Reference 4: PULS Reference (DI6) 5: Communication Reference 6: MIN (VF1, VF2) 7: MAX (VF1, VF2) 8: Operation Result 1 9: Operation Result 2 10: Operation Result 3 11: Operation Result 4 12: Standby Torque Source 1 13: Standby Torque Source 2	00

0: Digital Reference (P1.1.15)

The upper limit of the vector control torque is given by the value at based on Function Code P1.1.15.

1: External Terminal VF1 Reference

2: External Terminal VF2 Reference

The torque Reference is given by the analog input terminal. E Series Frequency inverter provides 2-way analog input terminal (VF1, VF2). VF1 and VF2 can input 0V~10V voltage or 0/4mA~20mA current. As for corresponding relation curve between the input of VF1 and VF2 and the torque set value, the users can freely choose from four kinds of the relation curves through function code P2.1.02, in which Curve 1 and Curve 2 are linear relationship able to be set through Function Code P2.0.13~P2.0.22, and Curve 3 and Curve 4 are broken line relationship with two inflection points able to be set through Function Code P2.1.04~P2.1.19. The deviation between actual voltage and sampling voltage of the analog input terminal can be adjusted through Function Code P8.1.05~P8.1.12.

3: Multiplex Directive Terminal Reference

The torque reference is given by different composite state of Multiplex Directive Terminal. E Series Frequency inverter is able to set four Multiplex Directive Terminals (Terminal Function 9~12, refer to the Description for Multiplex Directive Terminal Function of P2.0.00~P2.0.09 for more details)

## 4: PULS Reference (DI6)

The torque reference is given by high-speed impulse frequency of digital input terminal D16 (the terminal function is not defined). The corresponding relationship between high-speed impulse frequency and torque upper limit value can be set through Function Code P2.0.23~P2.0.26, that is, line relationship.

## 5: Communication Reference

The torque reference is given by the upper computer through communication mode (refer to Chapter VIII for more details).

## 6: MIN (VF1, VF2)

The torque reference is given by the input value of VF1 and VF2, whichever is lower.

## 7: MAX (VF1, VF2)

The torque reference is given by the input value of VF1 and VF2, whichever is larger.

## 8: Operation Result 1

## 9: Operation Result 2

## 10: Operation Result 3

## 11: Operation Result 4

The torque reference is determined by the operation results after setting calculation of the internal operation module. Refer to the Description for Function Code P3.2.26~P3.2.39 for more details of the operation module. The operation results can be viewed through Function Code 9.0.46~P9.0.49.

## 12: Standby Torque Source 1

## 13: Standby Torque Source 2

Standby Torque Source 1 and Standby Torque Source 2 are reserved by the manufacturer as frequency sources used for special occasions in future, so the users may ignore them as usual.

**Note: when the torque is set by VF1 & VF2, multiplex directive, PULSE, communication and operation results, the corresponding range is the value set by P1.1.15.**

Function code	Function name	Setting scope	Factory set value
P1.1.15	Torque Digital Reference	-200.0%~200.0%	150.0

When at P1.1.14=0, the set value of this function code determines the torque reference, which is the percentage relative to the rated torque of the motor.

Function code	Function Name	Setting scope	Factory set value
P1.1.16	Torque Control FWD Frequency Limit	000.00Hz~Highest Frequency	050.00
P1.1.17	Torque Control REV Frequency Limit	000.00Hz~Highest Frequency	050.00

This function code is used to set the highest frequency in forward and reverse running when the frequency inverter runs in torque control mode (i.e. P1.1.13=1).

Function code	Function name	Setting scope	Factory set value
P1.1.18	Torque Acceleration Time	0000.0s~6500.0s	0000.0
P1.1.19	Torque Deceleration Time	0000.0s~6500.0s	0000.0

These two function codes are used to set the acceleration time of the torque rise and the deceleration time of the torque decline when running in torque control mode (i.e. P1.1.13=1). They may be set to 0 for the occasions requiring rapid response.

## 6.3 Group P2 - Input/Output Terminal Function

## Group P2.0 - Basic Group

The input and output terminals of CDI-E100 Series, E102 Series and E180 Series are configured as below:

CDI-E100 Series	CDI-E102 Series	CDI-E180 Series
6-way digital input terminal (DI1~DI6), in which DI6 can connect high-speed Impulse Input	5-way digital input terminal (DI1~DI6), in which DI6 can connect high-speed Impulse Input	6-way digital input terminal (DI1~DI6), in which DI6 can connect high-speed Impulse Input. Additional 4-way digital input terminal (DI7~DI10) is added through externally connected I/O expansion card
2-way Analog Input (VF1 & VF2)	2-way Analog Input (VF1 & VF2)	Additional 1-way (VF3) is added through externally connected IO expansion card for 2-way analog input (VF1, VF2)
2-way Analog Input (FM1 & FM2)	1-way Analog Input FM1	2-way Analog Input (FM1 & FM2)
One-way Collector Output (YO) (Use Terminal YO/FMP as YO)	N/A	One-way Collector Output (YO) (Use Terminal YO/FMP as YO) can add additional 2-way (YO1 and YO2) through externally connected I/O expansion card
Two-way Relay Output (T1 & T2)	1-way Relay Output (T1 & T2)	2-way Relay Output (T1 & T2)
One-way Impulse Output Terminal (FMP) (Use Terminal YO/FMP as FMP)	N/A	One-way Impulse Output Terminal (FMP) (Use Terminal YO/FMP as FMP)
<b>Note: YO/FMP Terminal is common terminal of YO and FMP, but only one can be used at the same time (select through function code P2.1.20).</b>		

Function code	Function Name	Setting scope	Factory set value
P2.0.00	DI1 Terminal Function	0~59	01 ( FWD Running)
P2.0.01	DI2 Terminal Function	0~59	04 (REV Jogging)
P2.0.02	DI3 Terminal Function	0~59	09 (Multiplex Directive Terminal 1)
P2.0.03	DI4 Terminal Function	0~59	12 (Multiplex Directive Terminal 4)
P2.0.04	DI5 Terminal Function	0~59	13 (Fault Reset)
P2.0.05	DI6 Terminal Function	0~59	00
P2.0.06	DI7 Terminal Function	0~59	00
P2.0.07	DI8 Terminal Function	0~59	00
P2.0.08	DI9 Terminal Function	0~59	00
P2.0.09	DI10 Terminal Function	0~59	00

The above function codes are used to set the functions of digital input terminals and the functions for option are shown in the table below:

Set value	Function	Description
0	No Function	Define the not in-service terminals as “Unused” to prevent malfunctions.
1	Forward Running (FWD)	Control FWD and REV of the frequency inverter through these two terminals.
2	Reverse Running (REV)	
3	3-line Running Control	Confirm that the running mode of the frequency inverter is three-line control mode through this terminal. Refer to the Description for Terminal Control in 7.1.1.
4	Forward Jogging	Control FWD Jogging and REV Jogging through of the frequency inverter through these two terminals and be valid for any running control mode. The running frequency and acceleration & deceleration time of the inching refer to the description for P0.1.08, P0.1.09 and P0.1.10 .
5	Reverse Jogging	
6	Terminal UP	When the reference frequency is given by the keyboard, increase or decreases the reference frequency through these two terminals.
7	Terminal DOWN	
8	Free Stop	When the terminal state is valid, the frequency inverter is blocked to output, the shut-down of the motor is not subject to the control of the frequency inverter at this moment. This mode has same meaning of free stop described in P1.0.16.
9	Multiplex Directive Terminal 1	Realize the references of 16 kinds of the directive through 16 kinds of states of these four terminals.
10	Multiplex Directive Terminal 2	
11	Multiplex Directive Terminal 3	
12	Multiplex Directive Terminal 4	
13	Fault Reset (RESET)	Realize remote fault reset through this terminal and have same function with RESET Key on Keyboard.
14	Running Pause	When this terminal state is valid, the terminal slows down and stops, but all running parameter are memorized. When this terminal state is invalid, the frequency inverter is resets to running state before stop.
15	External Fault Input	When this terminal state is valid, the frequency inverter gives an alarm of Err13, and then the fault is handled based on fault protection action mode.
16	Acceleration & Deceleration Time Selection Terminal 1	Realize the switch among four groups of straight acceleration and deceleration time, refer to Appendix 3 for more details.
17	Acceleration & Deceleration Time Selection Terminal 2	
18	Frequency Source Selection Terminal 1	When at P0.1.00=8, the functions of these terminals are valid. Realize the switch among 8 kinds of frequency sources through 8 kinds of state of these three terminals.
19	Frequency Source Selection Terminal 2	
20	Frequency Source Selection Terminal 3	
21	Running Command Selection Terminal 1	Realize the switch among running control modes through close/open state of these two terminals
22	Running Command Selection Terminal 2	
23	UP/DOWN Reference Reset	When the reference frequency is given by the keyboard, this terminal can remove the frequency allowance adjusted by Terminal UP/DOWN or Key ▲ & ▼ on Keyboard to reset the reference frequency to the value given by P0.0.05.

Chapter 6. Description of Parameters

Set value	Function	Description
24	Prohibition of Acceleration & Deceleration	When this terminal state is valid, the output frequency of the frequency inverter is not impacted by the signal (except for stop command)
25	PID Pause	PID Control fails temporarily, the frequency inverter maintains the running of current output frequency and can't conduct PID Regulation of the frequency source.
26	PLC State Reset	During executing process of PLC, the frequency inverter is reset the frequency inverter to initial state of Simple PLC through this terminal
27	Wobblulating Pause	The frequency inverter outputs in central frequency and the wobblulating function suspends.
28	Counter Input	Be used for defining the output terminal of count impulse. If it is high-speed pulse, connect Terminal DI6.
29	Counter Reset	Conduct reset handling to counter.
30	Length Counting Input	Be used for defining the output terminal of length count impulse. If it is high-speed pulse, connect Terminal D16.
31	Length Reset	Conduct reset handling to length.
32	Torque Control Prohibition	Prohibit the frequency inverter from running in torque control mode, and the frequency inverter only can run in speed control mode.
33	PULS Impulse Input	Define PULS Impulse Input Terminal and connect Terminal DI6.
34	Immediate DC Brake	When this terminal state is valid, the frequency inverter is directly switched to DC Switch State.
35	External Fault Normally-closed Input	When this terminal state is invalid, the frequency inverter gives an alarm of Err13, and then the fault is handled based on fault protection action mode.
36	Frequency Modification Enable	When this terminal state is invalid, the frequency inverter cannot respond the modification to frequency. When this terminal state is valid, the frequency inverter responds the modification to frequency.
37	PID Action Direction Negation	When this terminal state is valid, the direction of PID Action is opposite to the direction given by P4.0.03. Additionally, when P0.0.06=2, the terminal is valid and the running direction adopts reversed direction.
38	External Stop Terminal 1	When the running control mode is keyboard control (P0.0.03=0), the terminal can stop through this terminal.
39	External Stop Terminal 2	In any of running control modes, the frequency inverter can slow down and stop at deceleration time 4 through this terminal.
40	PID Integral Stop	When the units digit of P4.2.08 is 1 (i.e. the integral separation is valid and this terminal is valid, the functions of integral regulation of PID stops temporarily, but the functions of proportional regulation and integral regulation of PID are still valid.

Set value	Function	Description
41	PID Parameter Switch	When the switch conditions of PID parameters are the terminal (P4.0.13=1), this terminal state is invalid, adopt PID Parameter 1. When this terminal state is valid, adopt PID Parameter 2.
42	Speed Control/Torque Control Switch	Realize the switch of the frequency inverter between torque control mode and speed control mode. This terminal state is invalid, the frequency inverter runs in setting mode of P1.1.13 (Speed/Torque Control Mode), when this terminal state is valid, it is switched to another mode.
43	Emergency Stop	When this terminal is valid, the frequency inverter outputs the voltage in enclosed mode and freely stops by inertia.
44	Deceleration DC Brake	When the terminal state is valid, the frequency inverter slows down to Start Frequency of Stop DC Brake and then is switched to Stop DC Brake State.
45	User-Defined Fault 1	When: User-Defined Fault 1 and 2 are valid, the frequency inverter respectively give an alarm of Err21 and Err22 and then the faults are handled based on fault protection action mode.
46	User-Defined Fault 2	
47	Running Time Reset	During the running process, it is to conduct reset handling for current running time, current running time can be viewed through Function Code P9.0.23.
48	Timer Input Terminal 1	When internal timer is controlled by this terminal, this terminal controls the start or stop of the timer, refer to the Description of Function Code P3.2.23.
49	Timer Input Terminal 2	When internal timer is controlled by this terminal, this terminal controls the start or stop of the timer, refer to the Description of Function Code P3.2.23.
50	Timer Reset Terminal 1	When internal timer reset is controlled by this terminal, this terminal state is valid, the timer resets, refer to the Description of Function Code P3.2.23.
51	Timer Reset Terminal 2	When internal timer reset is controlled by this terminal, this terminal state is valid, the timer resets, refer to the Description of Function Code P3.2.23.
52	Encoder Phase A Input	Define the signal input terminal of Encoder A and B. Terminal D15 and D16 of CDI-E100 Series can connect high-speed impulse of the encoder, the impulse frequency of the encoder of other terminals is not greater than 200Hz. The impulse frequency of CDI-E180 Series encoder must be less than 200Hz.
53	Encoder Phase B Input	
54	Distance Reset	Conduct reset handling to the distance
55	Integral Computation Reset	Reset the integral computation in operation module
56~59	User Function 1~4	Reservation
60	Start by tracing its rpm is prohibited	When setting as starting by tracing its rpm(P1.0.10=1), the terminal is effective and switches to start directly.

## Appendix 1 Description for Functions of Multiplex Directive Terminals

Terminal 4	Terminal 3	Terminal 2	Terminal 1	Multiplex Directive Reference	Corresponding parameter
OFF	OFF	OFF	OFF	Multiplex Directive 0	P3.0.03
OFF	OFF	OFF	ON	Multiplex Directive 1	P3.0.05
OFF	OFF	ON	OFF	Multiplex Directive 2	P3.0.07
OFF	OFF	ON	ON	Multiplex Directive 3	P3.0.09
OFF	ON	OFF	OFF	Multiplex Directive 4	P3.0.11
OFF	ON	OFF	ON	Multiplex Directive 5	P3.0.13
OFF	ON	ON	OFF	Multiplex Directive 6	P3.0.15
OFF	ON	ON	ON	Multiplex Directive 7	P3.0.17
ON	OFF	OFF	OFF	Multiplex Directive 8	P3.0.19
ON	OFF	OFF	ON	Multiplex Directive 9	P3.0.21
ON	OFF	ON	OFF	Multiplex Directive 10	P3.0.23
ON	OFF	ON	ON	Multiplex Directive 11	P3.0.25
ON	ON	OFF	OFF	Multiplex Directive 12	P3.0.27
ON	ON	OFF	ON	Multiplex Directive 13	P3.0.29
ON	ON	ON	OFF	Multiplex Directive 14	P3.0.31
ON	ON	ON	ON	Multiplex Directive 15	P3.0.33

**Explanation:** when the multiplex directive corresponds to frequency, the corresponding parameter is the percentage relative to highest frequency.

When the multiplex directive corresponds to torque, the corresponding parameter is the percentage relative to digital reference torque.

When the multiplex directive corresponds PID, the corresponding parameter is the percentage relative to PID Reference Feedback range.

## Appendix 2 Description for Functions of Frequency Source Selection Terminals

Terminal 3	Terminal 2	Terminal 1	Option of frequency source
OFF	OFF	OFF	Frequency source A (correspond to P0.1.00=0)
OFF	OFF	ON	Frequency source B (correspond to P0.1.00=1)
OFF	ON	OFF	Frequency source A+B (correspond to P0.1.00=2)
OFF	ON	ON	Frequency source A-B (correspond to P0.1.00=3)
ON	OFF	OFF	Max. value of A & B (correspond to P0.1.00=4)
ON	OFF	ON	Min. value of A & B (correspond to P0.1.00=5)
ON	ON	OFF	Backup frequency source 1 (correspond to P0.1.00=6)
ON	ON	ON	Backup frequency source 2 (correspond to P0.1.00=7)

## Appendix 3 Description for Functions of Acceleration and Deceleration Time Selection Terminals

Terminal 2	Terminal 1	Option of acceleration/ deceleration time	Corresponding parameters
OFF	OFF	Acceleration/ deceleration time 1	P0.0.11, P0.0.12
OFF	ON	Acceleration/ deceleration time 2	P0.0.11, P0.0.12
ON	OFF	Acceleration/ deceleration time 3	P0.1.13, P0.1.14
ON	ON	Acceleration/ deceleration time 4	P0.1.15, P0.1.16

## Appendix 4 Description for Functions of Running Command Selection Terminals

Current Running Control Mode	Terminal 2	Terminal 1	Running Control Mode
Keyboard Control (P0.0.03=0)	OFF	ON	Terminal Control
	ON	OFF	Communication Control
	ON	ON	Communication Control
Terminal Control (P0.0.03=1)	OFF	ON	Keyboard Control
	ON	OFF	Communication Control
	ON	ON	Keyboard Control
Communication Control (P0.0.03=2)	OFF	ON	Keyboard Control
	ON	OFF	Terminal Control
	ON	ON	Keyboard Control

**Note:** when Terminal 1 and Terminal 2 are OFF, it is the running control mode set by Function Code **P0.0.03**

Function code	Function name	Setting scope	Factory set value
P2.0.10	DI Filtering time	0.000s~1.000s	0.010

This function code is used to set the software filtering time of terminal DI input state. If the occasions, which use Terminal DI Input, are easily to lead to false operation by interference, this parameter can be increased to enhance the anti-interference ability, but the increase of the filtering time may cause slow response of Terminal DI.

Function code	Function name	Setting scope	Factory set value
P2.0.11	External Terminal Running Control Mode	0: Two-line Type 1 1: Two- line Type 2 2: Three- line Type 1 3: Three-line Type 2	0

This function code defines that when the control running mode is terminal control (i.e. P0.0.03=1), there are four different modes to control the running of the frequency inverter. Refer to Terminal Control in 7.1.1 for more details.

Function code	Function name	Setting scope	Factory set value
P2.0.12	UP/DOWN Terminal Change Rate	00.001Hz/s~65.535Hz/s	01.000

The function code defines that when Terminal UP/DOWN is used to regulate the reference frequency , set the rate of frequency variation.

When P0.2.04 (Decimal Point of Frequency) is 2, the value range is 00.001Hz/s~65.535Hz/s.

When P0.2.04 (Decimal Point of Frequency) is 1, the value range is 000.01Hz/s~655.35Hz/s.

Function code	Function name	Setting scope	Factory set value
P2.0.13	Minimum Input of Curve 1	00.00V~P2.0.15	00.00
P2.0.14	Corresponding reference for Minimum Input of Curve 1	-100.0%~100.0%	000.0
P2.0.15	Maximum Input of Curve 1	P2.0.13~10.00V	10.00
P2.0.16	Corresponding reference for Maximum Input of Curve 1	-100.0%~100.0%	100.0
P2.0.17	VF1 Filtering time	00.00s~10.00s	00.10

The above function codes are used to set the relation between analog input and corresponding reference value, that is, straight line relationship.

When the voltage of analog input is greater than the given “Max. Input of Curve 1” (P2.0.15), the analog is calculated at “Max. Input of Curve 1”; similarly when the voltage of analog input is lower than the given “Min. Input of Curve 1” (P2.0.13), the calculation shall be at min. input or 0.0% according to the setting of “ Curve below Mix. Input Reference Selection”.

VF1 Input Filtering Time is used to set the software filtering time of VF1, when the on-site analog is easily to be disturbed, the filtering time shall be increased to make the tested analog input to be stable, but the greater filtering time makes the response speed of the analog test become slow, so how to balanceset needs is based on actual situations of the applications.

**Explanation: when the analog inputs corresponding frequency, the corresponding given value is the percentage relative to highest frequency.**

**When the analog inputs corresponding torque, the corresponding given value is the percentage relative to digital reference torque.**

**When the analog inputs corresponding PID, the corresponding reference value is the percentage relative to PID Reference Feedback range.**

**When the analog inputs corresponding time, the corresponding given value is the percentage relative to running time (P3.1.02).**

**NOTE: The default value of inverter’s analog input is 0V ~ 10V. If the input is 0mA ~ 20mA, it will remain 0V ~ 10V; if the input is 4mA ~ 20mA, it will remain 2V ~ 10V.**

Function code	Function name	Setting scope	Factory set value
P2.0.18	Minimum Input of Curve 2	00.00V~P2.0.20	00.00
P2.0.19	Corresponding reference for Minimum Input of Curve 2	-100.0%~100.0%	000.0
P2.0.20	Maximum Input of Curve 2	P2.0.18~10.00V	10.00
P2.0.21	Corresponding reference for Maximum Input of Curve 2	-100.0%~100.0%	100.0
P2.0.22	VF2 Filtering time	00.00s~10.00s	00.10

The functions and use methods of Curve 2 refer to the Description of Curve 1.

Function code	Function name	Setting scope	Factory set value
P2.0.23	Minimum Input of PULS	0.00kHz~ P2.0.25	000.00
P2.0.24	Corresponding reference for Minimum Input of PULS	-100.0%~100.0%	000.0
P2.0.25	Maximum Input of PULS	P2.0.23~100.00kHz	050.00
P2.0.26	Corresponding reference for Maximum Input of PULS	-100.0%~100.0%	100.0
P2.0.27	PULS Filtering time	00.00s~10.00s	00.10

The above function codes are used to set the relation between PULS Impulse Frequency and corresponding reference value, that is, straight line relationship.

When the input impulse frequency is greater than the given “Max. PULS Input”(P2.0.25),the impulse frequency is calculated at “Max. PULS Input”; similarly, when the input impulse frequency is lower than the given “Min. PULS Input”(P2.0.23),the impulse frequency is calculated at “Min. PULS Input”.

PULS Input Filtering time is used to set the software filtering time of PULS Impulse Frequency, when the on-site impulse is easily to be disturbed, the filtering time shall be increased to make the tested impulse frequency trend to be stable, but the greater filtering time makes the response speed of detecting the impulse frequency become slow, so how to balanceset needs is based on actual situations of the applications.

**Note: when the PULS Impulse Frequency inputs corresponding frequency, the corresponding given value is the percentage relative to highest frequency.**

**When the PULS Impulse Frequency inputs corresponding torque, the corresponding given value is the percentage relative to digital reference torque.**

**When the PULS Impulse Frequency inputs corresponding PID, the corresponding given value is the percentage relative to PID Reference feedback range.**

Function code	Function name	Setting scope	Factory set value
P2.0.28	Expansion Card YO1 Function Selection (Invalid E100)	0~59	00
P2.0.29	T1 Relay Function Selection		01
P2.0.30	T2 Relay Function Selection (Invalid E102)		02
P2.0.31	Expansion Card YO2 Function Selection (Invalid E100)		00
P2.0.32	YO Function Selection (Use Terminal YO/FMP as YO,i.e.P2.1.20=1) (Invalid E102)		00

The above five function codes are used to select the functions of five multi-functional output terminals.

The Descriptions of multi-functional output terminals are as below:

Set value	Function	Description
0	No Function	Multi-functional output terminals have no any functions.
1	Frequency inverter under Running	When the frequency inverter is at running state, have output frequency (able to be zero) and output Signal ON.
2	Fault Stop Output	When the frequency inverter breaks down and shuts down, output Signal ON.
3	Frequency Level Testing FDT1 Output	Refer to the Description for Function Code P2.2.03 and P2.2.04.

Set value	Function	Description
4	Frequency Reached	Refer to the Description for Function Code P2.2.02.
5	Zero-speed Running (no output when shut down)	When the frequency inverter is at running state and the output frequency is 0Hz, output Signal ON.
6	Motor Overload Pre-alarm	Before overload protection action of the motor, the judgment can be made according to the threshold value of early alarm to overload, after exceeding the threshold value of early alarm, output Signal ON. Refer to the Description for Function Code P1.0.25 and P1.0.26.
7	Frequency inverter Overload Pre-alarm	The frequency inverter outputs Signal ON 10s prior to occurrence of overload protection.
8	Reference Count Value Reached	When actual accounting value reaches the set value of Function Code P3.1.11, output Signal ON.
9	Designated Count Value Reached	When actual accounting value reaches the set value of Function Code P3.1.12, output Signal ON.
10	Length Reached	When actual length (P9.0.13) reaches the length set by Function Code P3.1.08, output Signal ON.
11	PLC circulation cycle completed	When simple PLC running completes a cycle, output the impulse signal with the width of 250ms.
12	Accumulative Running Time Reached	When the accumulative running time of the frequency inverter reaches the time set by Function Code P2.2.01, output Signal ON.
13	Frequency Limit	When the output frequency of the frequency inverter reaches upper frequency or lower frequency, output Signal ON.
14	Torque Limit	When the output torque of frequency inverter reaches limit value of the torque in speed control mode, output Signal ON.
15	Ready for Running	When main circuits and control circuit power of the frequency inverter have been stable and the inventor hasn't defected out any fault information, and the frequency inverter is in running state, output Signal ON.
16	VF1>VF2	When the input value of VF1 is greater than the input value of VF2, output Signal ON.
17	Upper Frequency Reached	When the output frequency reaches upper frequency, output Signal ON.
18	Lower Frequency Reached (no output when shut down)	When the output frequency reaches lower frequency and the frequency inverter is in running state, output Signal ON.
19	Undervoltage state output	When the frequency inverter is in undervoltage state, output Signal ON.
20	Communication Reference	Refer to the Description of Chapter 8.
21	VF1 Output less than Lower Limit	When the value of the Analog VF1 Input is less than the value set by Function Code P2.2.19 (Lower Limit of VF1 Input), output Signal ON.
22	VF1 Output more Upper Limit	When the value of the Analog VF1 Input is greater than the value set by Function Code P2.2.20 (Upper Limit of VF1 Input), output Signal ON.

Set value	Function	Description
23	Zero-speed Running 2 (also output when shut down)	When the output frequency of the frequency inverter is 0Hz, output Signal ON. In Stop Mode, this signal is ON.
24	Accumulative Power-on Time Reached	When the accumulative power-on time of the frequency inverter reaches the time set by Function Code P2.2.00, output Signal ON.
25	Frequency Level Testing Output FDT2	Refer to the Description of Function Code P2.2.05 and P2.2.06.
26	Frequency 1 Reaches Output	Refer to the Description of Function Code P2.2.07 and P2.2.08
27	Frequency 2 Reaches Output	Refer to the Description of Function Code P2.2.09 and P2.2.10.
28	Current 1 Reaches Output	Refer to the Description of Function Code P2.2.15 and P2.2.16.
29	Current 2 Reaches Output	Refer to the Description of Function Code P2.2.17 and P2.2.18.
30	Timing Reaches Output	When the timing function selection (P3.1.00=1) is valid, this running time reaches the given timing time, the frequency inverter automatically shuts down, output Signal ON in the process of shutdown and stop.
31	VF1 Input Overlimit	When the value of the analog input is greater than the value (Upper Limit of VF1 Input)set by Function Code P2.2.20 or less than the value (Lower Limit of VF1 Input)set by Function Code P2.2.19, output Signal ON
32	In Off-load	In off-load state, the frequency inverter outputs Signal ON.
33	In Reverse Running	In reverse running state, the frequency inverter outputs Signal ON.
34	Zero-current State	Refer to the Description of Function Code P2.2.11 and P2.2.12.
35	Module Temperature Reached	When the radiator temperature of the module of the frequency inverter reaches the temperature set by Function Code P2.2.21, output Signal ON.
36	Output Current Overlimit	Refer to the Description of Function Code P2.2.13 and P2.2.14.
37	Lower Frequency Reached (also output when shut down)	When the output frequency reaches lower frequency or the reference frequency is less than the lower frequency in stop state, output Signal ON.
38	Alarm Output	When the frequency inverter fails, if the fault handling mode is continuous running, output Signal ON. If the fault handling mode is shutdown by speed reduction, output Signal ON in the process of shutdown by speed reduction.
39	PLC Phase Completed	When each phase of simple PLC is completed, output an impulse signal with the width of 200ms.
40	Current Running Time Reached	When current running time of the frequency inverter exceeds the value set by Function Code P2.2.22, output Signal ON and the frequency inverter cannot shut down.
41	Fault Output (Not Output for Undervoltage)	When the frequency inverter fails and shuts down, output Signal ON. Output Signal OFF in undervoltage state.
42	Time of Timer 1 Reached	When the time of Timer 1 reaches the time set by Function Code P3.2.24, output Signal ON.

Set value	Function	Description
43	Time of Timer 2 Reached	When the time of Timer 2 reaches the time set by Function Code P3.2.25, output Signal ON.
44	Time of Timer 1 Reached but Time of Timer 2 not Reached	When the time of Timer 1 reaches the time set by Function Code P3.2.24 and the time of Timer 2 fails to reach the time set by Function Code P3.2.25, output Signal ON.
45	User Function 1	Reservation
46	User Function 2	Reservation
47	User Function 3	Reservation
48	User Function 4	Reservation
49	User Function 5	Reservation
50	Synchronization Intermediate Relay M1	Have the same action with M1
51	Synchronization Intermediate Relay M2	Have the same action with M2
52	Synchronization Intermediate Relay M3	Have the same action with M3
53	Synchronization Intermediate Relay M4	Have the same action with M4
54	Synchronization Intermediate Relay M5	Have the same action with M5
55	Distance over Zero	When actual distance (P9.0.30) is greater than 0, output Signal ON.
56	Distance Set value 1 Reached	When actual distance (P9.0.30) reaches the distance set by Function Code P3.1.13, output Signal ON.
57	Distance Set value 2 Reached	When actual distance (P9.0.30) reaches the distance set by Function Code P3.1.14, output Signal ON.
58	Operation Result 2 greater than 0	When the result 2 of the operation module is greater than 0, output Signal ON.
59	Operation Result 4 greater than 0	When the result 4 of the operation module is greater than 0, output Signal ON.

Function code	Function Name	Setting scope	Factory set value
P2.0.33	Analog Output FM1 Reference	0~20	00
P2.0.34	Analog Output FM2 Reference (E102 invalid)		01
P2.0.35	FMP Output Reference (Use Terminal YO/FMP as FMP, i.e. P2.1.20=0) (E102 invalid)		00

Function Code P2.0.33 and P2.0.34 respectively define the functions of Analog Output FM1 and FM2. Function Code P2.0.35 defines FMP Impulse Output Function.

The output range of Analog Output FM1 and FM2 is 0V~10V voltage signal or 0mA~20mA current signal. The deviation between actual output voltage and target output voltage of the analog output terminal can be adjusted through Function Code P8.1.13~P8.1.20.

The range of FMP Output Impulse Frequency is 0.01kHz~P2.1.21 (Highest Frequency of FMP Output), P2.1.21 can be set among 0.01kHz~100.00kHz.

The calibration relation between range of impulse output or analog output and corresponding functions are shown in the table below:

Set value	Function	Corresponding Function of Impulse or Analog Output 0.0%~100.0%
0	Running Frequency	0~Max. Output Frequency
1	Output Current	0~Max. Output Frequency
2	Output Torque (Absolute Value of Torque)	0~2 Times of Rated Current of the Motor
3	Output Torque	0~2 Times of Rated Torque of the Motor
4	Output Power	0~2 Times of Rated Power
5	Output Voltage	0~1.2 Times of Rated Voltage of the Frequency inverter
6	PULSE Impulse Input	0.01kHz~100.00kHz
7	VF1 Voltage	0V~10V (or 0/4mA~20mA)
8	VF2 Voltage	0V~10V (or 0/4mA~20mA)
9	Keyboard Potentiometer Voltage	0V~10V
10	Actual Length Value	0~Reference Length Value (Set value of Function Code P3.1.08)
11	Actual Counting Value	0~Designated Count Value (Set value of Function Code P3.1.12)
12	Communication Reference	Refer to the Description of Chapter VIII.
13	Motor Speed	0~Corresponding Speed of Max. Output Frequency
14	Output Current	0.0A~1000.0A
15	Bus line voltage	0.0V~1000.0V
16	Output Torque	-2 Times of Rated Torque of the Motor ~ 2 Times of Rated Torque of the Motor
17	Operation Result 1	-1000~1000
18	Operation Result 2	0~1000
19	Operation Result 3	-1000~1000
20	Operation Result 4	0~1000

Function code	Function name	Setting scope	Factory set value
P2.0.36	Analog FM1 Output Offset	-100.0%~100.0%	000.0
P2.0.37	Analog FM1 Output Gains	-10.00~10.00	01.00
P2.0.38	Analog FM2 Output Offset (E102 invalid)	-100.0%~100.0%	000.0
P2.0.39	Analog FM2 Output Gains (E102 invalid)	-10.00~10.00	01.00

The above function codes are generally used for correcting zero drift of analog output and deviation of output amplitude, but also can be used to customize the required analog output curve.

Actual Analog Output= Standard Analog Output × Analog Output Gain+ Analog Output Offset

Standard Analog Output refers to the output analog value without offset and gain correction. Namely, voltage output is 0 ~ 10V and current output is 0 ~ 20mA

The analog output bias is percentage of the max. voltage 10 V or current 20mA of standard analog output

For example: if output current signal is 4 ~ 20mA, analog output bias is set to 20% and analog output gain is set to 0.8.

## Group P2.1 Expansion Group

Function code	Function name	Setting scope	Factory set value
P2.1.00	Valid Model Selection 1 of Terminal DI	0: Active High Level 1: Active Low Level Ones: DI1 (E102 invalid) Tens: DI2 Hundreds: DI3 Thousands: DI4 Ten Thousands: DI5	00000
P2.1.01	Valid Model Selection 2 of Terminal DI	0: Active High Level 1: Active Low Level Ones: DI6 Tens: DI7 (Invalid E100) Hundreds: DI8 (Invalid E100) Thousands: DI9 (Invalid E100) Ten Thousands: DI10 (Invalid E100)	00000

Be used for setting valid state mode of digital input terminal.

When selecting active high level, it is not valid until corresponding Terminal DI is connected, and the disconnection is invalid.

When selecting active low level, it is not valid until corresponding Terminal DI is connected, and the disconnection is invalid.

**Note: DI7~DI10 are the terminals of CDI-E180 Series on Expansion Card I/O, but invalid for CDI-E100 and E102 Series.**

**DI1 is invalid for E102 Series.**

Function code	Function name	Setting scope	Factory set value
P2.1.02	Analog Input Curve Selection	Ones: Curve Selected for VF1 Tens: Curve Selected for VF2 1: Curve 1 2: Curve 2 3: Curve 3 4: Curve 4 Hundreds: VF1 input resolution Thousands: VF2 input resolution Ten Thousands: Keyboard Potentiometer input resolution 0:00.01Hz 1:00.02Hz 2:00.05Hz 3:00.10Hz 4:00.20Hz 5:00.50Hz 6:01.00Hz(Keyboard Potentiometer is invalid)	00021

The ones and tens of this function code are respectively used to select corresponding given curve of analog. Two analog inputs can respectively select any one of four kinds of the curves. Curve 1 and Curve 2 are linear relationship, refer to the setting of P2.0.13~P2.0.22 for more details, while Curve 3 and Curve 4 are broken line relationship with two inflection points, refer to the setting of P2.1.04~P2.1.19 for more details. Hundreds, thousands and ten thousands are used to select the input frequency resolution, minimum fluctuation value, of VF1, VF2 and keyboard potentiometer.

Function code	Function name	Setting scope	Factory set value
P2.1.03	Selection for Curve less than Min. Reference	Ones: VF1 less than Min. Input Tens: VF2 less than Min. Input 0: Corresponding Min. Input Reference 1: 0.0%	H.00

This function code is used to set how to determine the corresponding reference of the analog when the analog input is less than the given "Min. Input".

The ones and tens of this function code respectively correspond to VF1 and VF2. If it is 0, when VF input is lower than “Min. Input”, this corresponding reference of this analog is “Corresponding reference of Min. Input” (P2.0.14, P2.0.19, P2.1.05, P2.1.13) of the selected curve. If it is 1, when VF input is lower than “Min. Input”, this corresponding reference of this analog is 0.0%.

Function code	Function name	Setting scope	Factory set value
P2.1.04	Min. Input of Curve 3	00.00V~P2.1.06	00.00
P2.1.05	Corresponding reference for Min. Input of Curve 3	-100.0%~100.0%	000.0
P2.1.06	Curve 3 Inflection Point 1 Input	P2.1.04~ P2.1.08	03.00
P2.1.07	Corresponding reference for Curve 3 Inflection Point 1 Input	-100.0%~100.0%	030.0
P2.1.08	Curve 3 Inflection Point 2 Input	P2.1.06~ P2.1.10	06.00
P2.1.09	Corresponding reference for Curve 3 Inflection Point 2 Input	-100.0%~100.0%	060.0
P2.1.10	Max. Input of Curve 3	P2.1.08~10.00V	10.00
P2.1.11	Corresponding reference for Max. Input of Curve 3	-100.0%~100.0%	100.0

The functions and use methods of Curve 3 is roughly the same with Curve 1 and Curve 2 (refer to the Description of Curve 1), the difference is that Curve 1 and Curve 2 are linear relationship without inflection point, but curve 3 is broken line relationship with two inflection point in the middle, refer to the Description in the figure below:

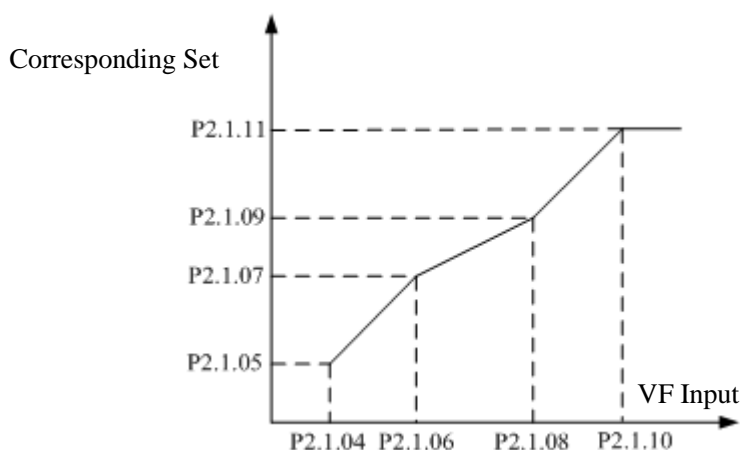

Function code	Function name	Setting scope	Factory set value
P2.1.12	Min. Input of Curve 4	00.00V~P2.1.14	00.00
P2.1.13	Corresponding reference for Min. Input of Curve 4	-100.0%~100.0%	-100.0
P2.1.14	Curve 4 Inflection Point 1 Input	P2.1.12~P2.1.16	03.00
P2.1.15	Corresponding reference for Curve 4 Inflection Point 1 Input	-100.0%~100.0%	-030.0
P2.1.16	Curve 4 Inflection Point 2 Input	P2.1.14~P2.1.18	06.00
P2.1.17	Corresponding reference for Curve 4 Inflection Point 2 Input	-100.0%~100.0%	030.0
P2.1.18	Max. Input of Curve 4	P2.1.16~10.00V	10.00
P2.1.19	Corresponding reference for Max. Input of Curve 4	-100.0%~100.0%	100.0

As for the functions and use methods of Curve 4, refer to the Description of Curve 3.

Function code	Function name	Setting scope	Factory set value
P2.1.20	YO/FMP Terminal Function (E102 invalid)	0: Impulse output (FMP) 1: Open Collector Output (YO)	1

This function code is used to define that the Terminal YO/FMP is used as impulse output function or open collector function.

If it is used as impulse output (i.e.P2.1.20=0), specific function refers to the Description for Function Code P2.0.35, and the high frequency of the output impulse is determined by the set value of Function Code P2.1.21 at the moment.

If it is used as open collector function (i.e.P2.1.20=1), specific function refers to the Description for Function Code P2.0.32.

Function Code	Function name	Setting Scope	Factory set value
P2.1.21	Highest Frequency of FMP Output (E102 invalid)	000.01kHz~100.00kHz	050.00

This function code is used to set the highest frequency of output impulse when Terminal YO/FMP is used as impulse output (i.e.P2.1.20=0)

Function code	Function name	Setting scope	Factory set value
P2.1.22	Valid State of Multi-functional Output Terminal	0: Positive Logic 1: Negative Logic Ones: YO (Invalid E102) Tens: T1 Hundreds: T2 (Invalid E102) Thousands: Expansion Card YO1 (Invalid E100) Ten Thousands: Expansion Card YO2 (Invalid E100)	00000

The ones, tens, hundreds, thousands and ten thousands of this function code respectively define the output logic of Output Terminal YO, T1, T2, Expansion Card YO1 and YO2.

0: Positive Logic

When the output signal is valid, the multi-functional output terminal is connected. But When the output signal is invalid, the multi-functional output terminal is disconnected.

1: Negative Logic

When the output signal is invalid, the multi-functional output terminal is connected. But when the output signal is valid, the multi-functional output terminal is disconnected.

Function code	Function name	Setting scope	Factory set value
P2.1.23	VF1 Terminal Function as Digital Input	00: Use as Normal Analog 01~59: Digital Input Terminal Function	00
P2.1.24	VF2 Terminal Function as Digital Input	00: Use as Normal Analog 01~59: Digital Input Terminal Function	00

This group of function codes is used to set the functions when the analog input terminal VF is used as digital input terminal DI. When VF is used as DI, VF and 10V are connected, VF Terminal State is high level, when VF and 10V are disconnected, and VF Terminal State is low level. the setting refers to the use and Description of the functions refer to Function Code P2.0.00~P2.0.09.

Function code	Function name	Setting scope	Factory set value
P2.1.25	Valid State Option of VF	0: Active High Level 1: Active Low Level Ones: VF1 Tens: VF2	00

This function code is used to confirm that the analog input terminal VF is used as digital input terminal DI , VF Terminal State is active high level or active low level. Ones and Tens respectively represent VF1 and VF2.

Active High Level: the connection of VF and 10V is valid, but disconnection is invalid.

Active Low Level: the connection of VF and 10V is valid, but disconnection is invalid.

Function code	Function Name	Setting scope	Factory set value
P2.1.26	DI1 Delay (E102 invalid)	0.0s~3600.0s	0000.0
P2.1.27	DI2 Delay	0.0s~3600.0s	0000.0
P2.1.28	DI3 Delay	0.0s~3600.0s	0000.0

The above functions are used to set the delayed time arising from the impact of the signal on frequency inverter when changes occur in signal DI1, DI2 and DI3.

Function code	Function Name	Setting scope	Factory set value
P2.1.29	YO Delay (E102 invalid)	0.0s~3600.0s	0000.0
P2.1.30	T1 Delay	0.0s~3600.0s	0000.0
P2.1.31	T2 Delay (E102 invalid)	0.0s~3600.0s	0000.0

The above function codes are used to set the delayed time of the frequency inverter from generating signal YO, T1 and T2 to output signal YO, T1 and T2.

Group P2.2 - Auxiliary Group

Function code	Function name	Setting scope	Factory set value
P2.2.00	Accumulative Power-on Reaches Reference Time	0h~65000h	00000

This function code is used to set accumulative power-on time of the frequency inverter from the date of leaving the factory. When actually accumulative power-on time reaches the value set by Function Code P2.2.00, the multi-functional output terminals of the frequency inverter output Signal ON. The corresponding function of multi-functional output terminals is accumulative power-on Time Reached (24). The frequency inverter gives an alarm of Fault Err23. If the setting is 0, the accumulative power-on time is not limited. Actually accumulative power-on time can be viewed through Function Code P5.1.01.

**Note: Only when actually accumulative power-on time (P5.1.01) is less than the value set by Function Code P2.2.00, the frequency inverter can enter into normal running, if the setting is 0, the accumulative power-on time is not limited.**

Function code	Function name	Setting scope	Factory set value
P2.2.01	Accumulative Running Reaches Reference Time	0h~65000h	00000

This function code is used to set accumulative running time of the frequency inverter. When actually accumulative running time reaches the value set by Function Code P2.2.01, the multi-functional output terminals of the frequency inverter output Signal ON and the frequency inverter shuts down automatically. The corresponding function of multi-functional output terminals is accumulative running Time Reached (12). The frequency inverter gives an alarm of Fault Err24. Actually accumulative running time can be viewed through Function Code P5.1.00.

**Note: Only when actually accumulative running time (P5.1.00) is less than the value set by Function Code P2.2.01, the frequency inverter can enter into normal running, if the setting is 0, the accumulative running time is not limited.**

Function code	Function name	Setting scope	Factory set value
P2.2.02	The reference frequency reaches test width	000.0%~100.0%	000.0

When the running frequency of frequency inverter is within positive and negative frequency with test width of the reference frequency, the multi-functional output terminals of the frequency inverter output Signal ON. The reference value of this function code is the percentage relative to the high reference frequency. Corresponding function of multi-functional output terminals is Frequency Reached (4), refer to the Description of the figure below:

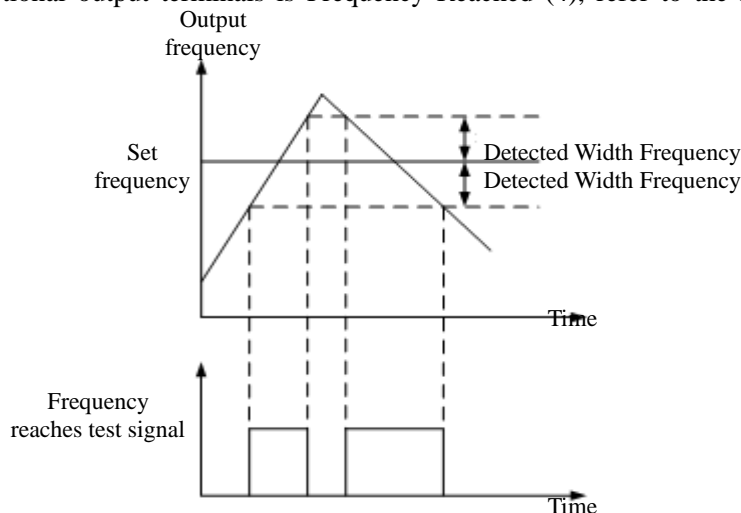

Test width Frequency= The reference frequency reaches test width (P2.2.02) × Highest Frequency (P0.0.07)

Function code	Function name	Setting scope	Factory set value
P2.2.03	Frequency Test FDT1	000.00Hz~Highest Frequency	050.00
P2.2.04	FDT1 Lagged Value	000.0%~100.0%	005.0

When the output frequency of the frequency inverter exceeds one value, the multi-functional output terminals of the frequency inverter output Signal ON, this value is called as Tested Frequency FDT1. When the output frequency of the frequency inverter is lower than a certain value of Tested Frequency FDT1, the multi-functional output terminals of the frequency inverter output Signal OFF, this value is called as Lagged FDT1 Frequency Value. Corresponding function of multi-functional output terminals is Detected FDT1 Output of Frequency Level (3), refer to the Description of the figure below:

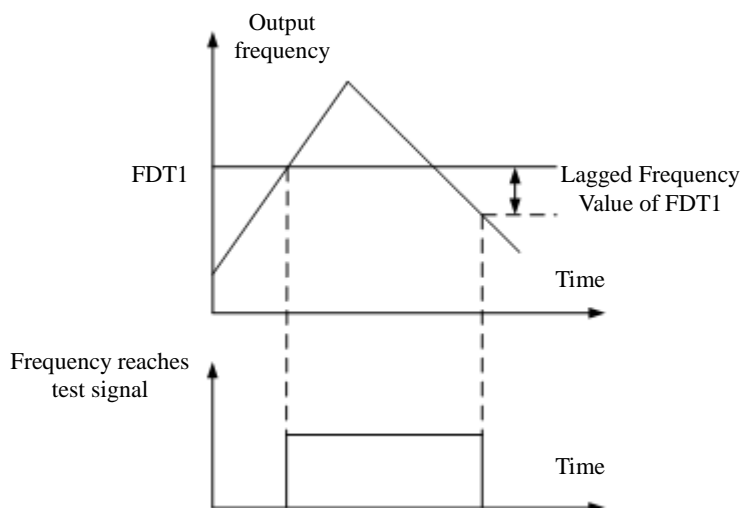

Lagged FDT1 Frequency Value= Tested Frequency FDT1 (P2.2.03) × Lagged Value of FDT1

Function code	Function name	Setting scope	Factory set value
P2.2.05	Frequency Test FDT2	000.00Hz~Highest Frequency	050.00
P2.2.06	FDT2 Lagged Value	000.0%~100.0%	005.0

FDT2 has the same function with FDT1, refer to the Description for FDT1 (P2.2.03 and P2.2.04) for more details. Corresponding function of multi-functional output terminals is Frequency Level Test FDT2 (25).

Function code	Function name	Setting scope	Factory set value
P2.2.07	Any reached frequency tested value 1	000.00Hz~Highest Frequency	050.00
P2.2.08	Any reached frequency 1 test width	000.0%~100.0%	000.0

When the running frequency of the frequency inverter is within any positive and negative frequency with test width of the reference frequency that reaches at Tested Frequency Value 1, the multi-functional output terminals of the frequency inverter output Signal ON. When the running frequency of the frequency inverter is beyond any positive and negative frequency with test width of the reference frequency that reaches at Tested Frequency Value 1, the multi-functional output terminals of the frequency inverter output Signal OFF. Corresponding function of the multi-functional output terminals is Frequency 1 Reaches Output (26), refer to the Description of the figure below:

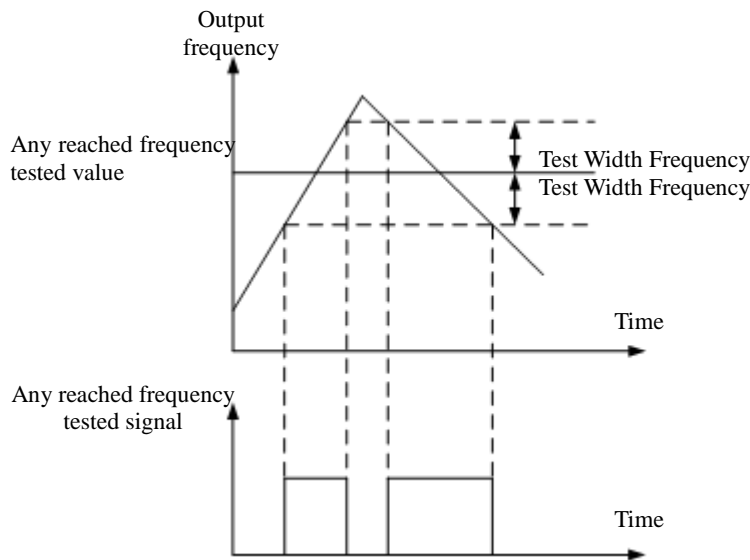

Test width Frequency = Any reached frequency 1 test width (P2.2.08) × Highest Frequency (P0.0.07)

Function code	Function name	Setting scope	Factory set value
P2.2.09	Any reached frequency tested value 2	000.00Hz~Highest Frequency	050.00
P2.2.10	Any reached frequency 2 test width	000.0%~100.0%	000.0

The above function codes have the same function with Function Code P2.2.07 and P2.2.08, refer to the Description of P2.2.07 and P2.2.08 for more details. Corresponding function of the multi-functional output terminals is Frequency 2 Reaches Output (27).

Function code	Function name	Setting scope	Factory set value
P2.2.11	Zero Current Test Level	000.0%~300.0% (100.0% correspond to rated current of motor)	005.0
P2.2.12	Delay Time for Zero Current Test	000.01s~600.00s	000.10

When the running current of the frequency inverter is less than or equal to zero-current test level and the duration exceeds the delay time of zero-current test, the multi-functional output terminals of the frequency inverter output Signal ON, once the running current resets to the current test level larger than zero, the multi-functional output terminals of the frequency inverter output Signal OFF. Corresponding function of the multi-functional output terminals is zero-current state (34), refer to the Description of the figure below:

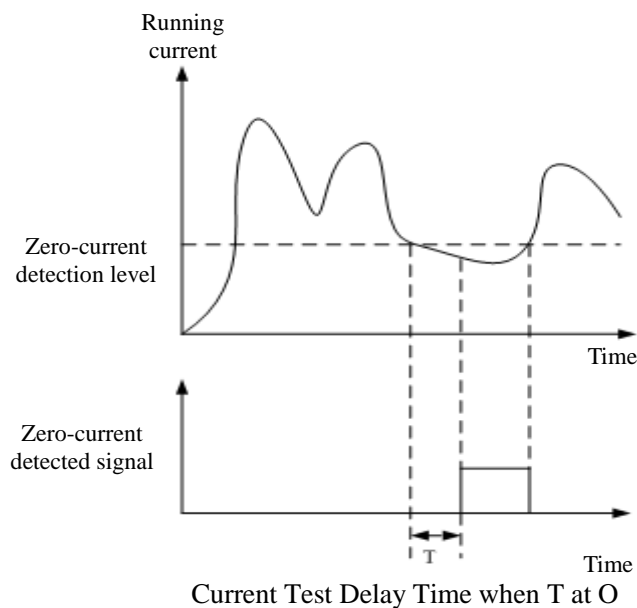

Function code	Function name	Setting scope	Factory set value
P2.2.13	Output Current Overlimit Value	00.0: No Test 000.1%~300.0%	200.0
P2.2.14	Delay Time for Current Overlimit Test	000.00s~600.00s	000.00

When the running current of the frequency inverter is greater than the value set by Function Code P2.2.13 and the duration exceeds the value set by Function Code P2.2.14, the multi-functional output terminals of the frequency inverter output Signal ON, once the running current resets to the value less than and equal to overlimit of output current, the multi-functional output terminals of the frequency inverter output Signal OFF. Corresponding function of the multi-functional output terminals is output current overlimit (36), refer to the Description of the figure below:

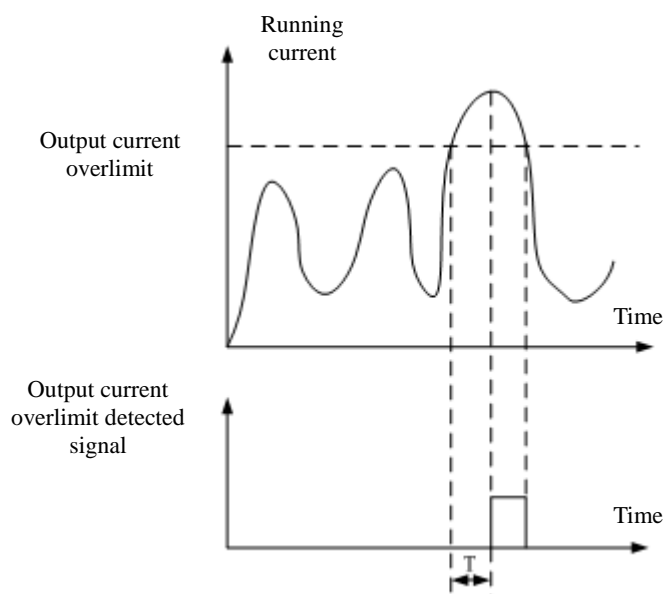

The output current overlimit is the percentage of rated current of the motor. T refers to the delay time of detecting out current overlimit.

Function code	Function name	Setting scope	Factory set value
P2.2.15	Current Level Test 1	000.0%~300.0%	100.0
P2.2.16	Test Width of Current Level 1	000.0%~300.0%	000.0

When the running current of the frequency inverter is within positive and negative frequency with test width of the current level test 1, the multi-functional output terminals of the frequency inverter output Signal ON. When the running current of the frequency inverter is beyond positive and negative test width of current level test 1, the multi-functional output terminals of the frequency inverter output Signal OFF. Corresponding function of the multi-functional output terminals is Current 1 Reaches Output (28), refer to the Description of the figure below:

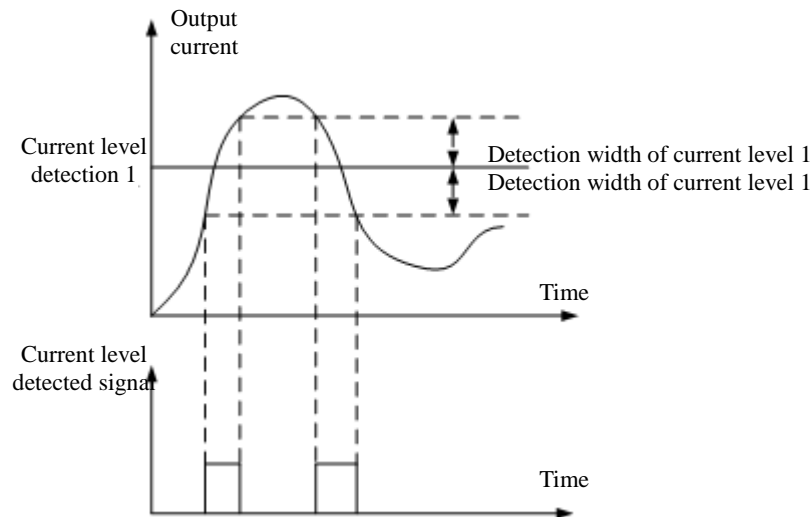

Current Level Test 1 and Test Width of Current Level 1 are the percentage of the rated current of the motor.

Function code	Function name	Setting scope	Factory set value
P2.2.17	Current Level Test 2	000.0%~300.0%	100.0
P2.2.18	Test Width of Current Level 2	000.0%~300.0%	000.0

The above function codes have the same functions with Function Code P2.2.15 and P2.2.16, refer to the Description of Function Code P2.2.15 and P2.2.16 for more details. Corresponding function of the multi-functional output terminals is Current 2 Reaches Output (29).

Function code	Function name	Setting scope	Factory set value
P2.2.19	VF1 Input Lower Limit	00.00V~P2.220	03.10
P2.2.20	VF1 Input Upper Limit	P2.219~11.00V	06.80

When the input value of Analog VF1 is less than the value set by Function Code P2.2.19, the multi-functional output terminals of the frequency inverter output Signal ON. Corresponding function of the multi-functional output terminals is VF Input less than lower limit (21) or above limit (31).

When the input value of Analog VF1 is less than the value set by Function Code P2.2.20, the multi-functional output terminals of the frequency inverter output Signal ON. Corresponding function of the multi-functional output terminals is VF Input less than lower limit (22) or above limit (31).

Function code	Function name	Setting scope	Factory set value
P2.2.21	Model Temperature Reaches Reference	000℃~100℃	075

The module temperature of the frequency inverter reaches the value set by Function Code P2.2.21, the multi-functional output terminals of the frequency inverter output Signal ON. Corresponding function of the multi-functional output terminals is Module Temperature Reached (35). Actual module temperature can be viewed through Function Code P5.1.03.

Function code	Function name	Setting scope	Factory set value
P2.2.22	Current Running Reaches Reference Time	0000.0~6500.0min	0000.0

The frequency inverter needs to restart timing for every start, when reaching the value set by Function Code P2.2.22, the frequency inverter continues to run and the multi-functional output terminals of the frequency inverter output Signal ON. Corresponding function of multi-functional output terminals is Current Running Time Reached (40). If the set is 0, current running time is not limited. Actual time of current running can be viewed through Function Code P9.0.23 (when the frequency inverter shuts down, the display value of P9.0.23 automatically resets to 0).

## 6.4 Group P3 - Programmable Function

## Group P3.0 - Basic Group

Function code	Function name	Setting scope	Factory set value
P3.0.00	Simple PLC Running Mode	0: End of Single Running and Stop 1: End of Single Running and Save Final Value 2: Continuous Running 3: Cycle N Times	0

## 0: Stop after End of Single Cycle

The frequency inverter stops automatically according to the stopping method set by P1.0.16 after completing one cycle.

## 1: Keep Final Value after End of Single Running

The frequency inverter runs at reference frequency of final phase after completing one cycle.

## 2: Continuous Cycle

The frequency inverter continues to run until the stop command is given.

## 3: N Times of Cycle

The frequency inverter stops automatically after cycling N times. N is set by reference value of Function Code P3.0.01.

Function code	Function name	Setting scope	Factory set value
P3.0.01	Cycle number(s), N	00000~65000	00000

This function code is used to set the times of cycle running at Function Code P3.0.00=3.

Function code	Function name	Setting scope	Factory set value
P3.0.02	Option of PLC Power-off Memory	Ones: Option of Power-off Memory 0: No Power-off Memory 1: Power-off Memory Tens: Stop Memory Selection 0: No Stop Memory 1: Stop Memory	00

PLC Power-off Memory means running phase and running frequency of PLC before memory power-off, when powering on next time, the frequency inverter continues to run from memory phase. If it is selected not to memory, every power-on needs to restart the process of PLC.

PLC Stop Memory means running phase and running frequency of PLC before memory shutdown, when running next time, the frequency inverter continues to run from memory phase. If it is selected not to memory, every start needs to restart the process of PLC.

In addition, PLC recycling times can be realized memorizing by selecting this function.

Function code	Function name	Setting scope	Factory set value
P3.0.03	Phase Directive 0	-100.0%~100.0%	000.0
P3.0.04	Phase O Running Time	0000.0s~6553.5s	0000.0
P3.0.05	Phase Directive 1	-100.0%~100.0%	000.0
P3.0.06	Phase 1 Running Time	0000.0s~6553.5s	0000.0
P3.0.07	Phase Directive 2	-100.0%~100.0%	000.0
P3.0.08	Phase 2 Running Time	0000.0s~6553.5s	0000.0
P3.0.09	Phase Directive 3	-100.0%~100.0%	000.0
P3.0.10	Phase 3 Running Time	0000.0s~6553.5s	0000.0
P3.0.11	Phase Directive 4	-100.0%~100.0%	000.0
P3.0.12	Phase 4 Running Time	0000.0s~6553.5s	0000.0
P3.0.13	Phase Directive 5	-100.0%~100.0%	000.0
P3.0.14	Phase 5 Running Time	0000.0s~6553.5s	0000.0
P3.0.15	Phase Directive 6	-100.0%~100.0%	000.0
P3.0.16	Phase 6 Running Time	0000.0s~6553.5s	0000.0
P3.0.17	Phase Directive 7	-100.0%~100.0%	000.0
P3.0.18	Phase 7 Running Time	0000.0s~6553.5s	0000.0
P3.0.19	Phase Directive 8	-100.0%~100.0%	000.0
P3.0.20	Phase 8 Running Time	0000.0s~6553.5s	0000.0
P3.0.21	Phase Directive 9	-100.0%~100.0%	000.0
P3.0.22	Phase 9 Running Time	0000.0s~6553.5s	0000.0
P3.0.23	Phase Directive 10	-100.0%~100.0%	000.0
P3.0.24	Phase 10 Running Time	0000.0s~6553.5s	0000.0
P3.0.25	Phase Directive 11	-100.0%~100.0%	000.0
P3.0.26	Phase 11 Running Time	0000.0s~6553.5s	0000.0
P3.0.27	Phase Directive 12	-100.0%~100.0%	000.0
P3.0.28	Phase 12 Running Time	0000.0s~6553.5s	0000.0
P3.0.29	Phase Directive 13	-100.0%~100.0%	000.0
P3.0.30	Phase 13 Running Time	0000.0s~6553.5s	0000.0
P3.0.31	Phase Directive 14	-100.0%~100.0%	000.0
P3.0.32	Phase 14 Running Time	0000.0s~6553.5s	0000.0
P3.0.33	Phase Directive 15	-100.0%~100.0%	000.0
P3.0.34	Phase 16 Running Time	0000.0s~6553.5s	0000.0

When the tens for each phase property of the multiplex directive is 0, the corresponding reference value of Simple PLC Running and each phase of the multiplex directive are the percentage relative to the highest frequency. The phase running time is the duration of PLC running at the frequency of each phase (including acceleration and deceleration time and FWD and REV Dead Time).

Function code	Function name	Setting scope	Factory set value
P3.0.35	Phase 0 Attribution	Ones: Acceleration & Deceleration Time	H.00
P3.0.36	Phase 1 Attribution	Selection (Invalid Multiplex Directive)	H.00
P3.0.37	Phase 2 Attribution	0: Acceleration & Deceleration Time 1	H.00
P3.0.38	Phase 3 Attribution	1: Acceleration & Deceleration Time 2	H.00
P3.0.39	Phase 4 Attribution	2: Acceleration & Deceleration Time 3	H.00
P3.0.40	Phase 5 Attribution	3: Acceleration & Deceleration Time 4	H.00
P3.0.41	Phase 6 Attribution	Tens: Frequency Source Selection (Valid Multiplex Directive)	H.00
P3.0.42	Phase 7 Attribution	0: Current Phase Directive	H.00
P3.0.43	Phase 8 Attribution	1: Keyboard Potentiometer	H.00
P3.0.44	Phase 9 Attribution	2: Keyboard Frequency Reference	H.00
P3.0.45	Phase 10 Attribution	3: VF1 Input	H.00
P3.0.46	Phase 11 Attribution	4: VF2 Input	H.00
P3.0.47	Phase 12 Attribution	5: PULS Reference (DI6)	H.00
P3.0.48	Phase 13 Attribution	6: PID Reference	H.00
P3.0.49	Phase 14 Attribution	7: Operation Result 1	H.00
P3.0.50	Phase 15 Attribution	8: Operation Result 2	H.00
		9: Operation Result 3	
		A: Operation Result 4	
		Hundreds unit: running direction	
		0: Default Direction	
		1: Reversed Direction	

The ones of the phase property determine the acceleration and deceleration time of Simple PLC running at each phase and the tens of phase property determine the frequency source of Simple PLC Running or Multiplex Directive at each phase. The hundreds unit of phase attribute is determined by running direction of simple PLC at each phase.

Function Code	Function name	Setting Scope	Factory set value
P3.0.51	Simple PLC Running Time Unit	0: Second 1: Hour 2: Minute	0

Refer to the unit of phase running time when the frequency inverter is at Simple PLC Running.

Function code	Function Name	Setting scope	Factory set value
P3.1.00	Timing Function Selection	0: Invalid 1: Valid	0
P3.1.01	Fixed Running Time Selection	0: Digital Reference (P3.1.02) 1: External Terminal VF1 Reference 2: External Terminal VF2 Reference (Analog input range corresponds to P3.1.02)	0
P3.1.02	Fixed Running Time	0000.0min~6500.0min	0000.0

The above function codes are used to complete the timing run function of the frequency inverter. Refer to 7.1.8 for more details (Timing Function).

Function code	Function name	Setting scope	Factory set value
P3.1.03	Wobblating Reference Mode	0: Relative to Reference frequency 1: Relative to Highest Frequency	0
P3.1.04	Wobblating Range	000.0%~100.0%	000.0
P3.1.05	Kicking Range	00.0%~50.0%	00.0
P3.1.06	Wobblating Cycle	0000.1s~3000.0s	0010.0
P3.1.07	Rise Time of Wobblating Triangular Wave	000.1%~100.0%	050.0

The above function codes are used for wobblating function. Refer to 7.1.16 for more details (wobblating function).

Function code	Function name	Setting scope	Factory set value
P3.1.08	Reference Length	00000m~65535m	01000
P3.1.09	Actual Length	00000m~65535m	00000
P3.1.10	Impulse Count per meter	0000.1~6553.5	0100.0

The above function codes are used for fixed-length control. Refer to 7.1.9 for more details (fixed-length function).

Function code	Function name	Setting scope	Factory set value
P3.1.11	Reference Count Value	00001~65535	01000
P3.1.12	Designated Count Value	00001~65535	01000

The above function codes are used for counting control. Refer to 7.1.10 for more details (Counting Function).

Function code	Function name	Setting scope	Factory set value
P3.1.13	Distance Set value 1	-3200.0~3200.0	0000.0
P3.1.14	Distance Set value 2	-3200.0~3200.0	0000.0
P3.1.15	Impulse Count per Distance	000.00~600.00	000.00

The above function codes are used for distance control. Refer to 7.1.11 for more details (Distance Control Function).

### P3.2 Built-in Logic PLC Function

Function code	Function Name	Setting scope	Factory set value
P3.2.00	Intermediate Delay Relay Control	0: the input of this relay is determined by this Relay Control Word A 1: the input of this relay is determined by this Relay Control Word B 2: the input of this relay is determined by this Relay Control Word C Ones: Relay 1 (M1) Tens: Relay 2 (M2) Hundreds: Relay 3 (M3) Thousands: Relay 4 (M4) Ten Thousands: Relay 5 (M5)	00000

This function is used to set which control word determines the Intermediate Delay Relay.

When at 0, the Intermediate Delay Relay is determined by Control Word A, refer to the Description for Function Code P3.2.01.

When at 1, the Intermediate Delay Relay is determined by Control Word B, refer to the Description for Function Code P3.2.02~P3.2.06.

When at 2, the Intermediate Delay Relay is determined by thousands and hundreds of Control Word C, refer to the Description for Function Code P3.2.07~P3.2.11.

Refer to the explanation for 7.1.12 (Simple Internal Relay Programmable Function).

Function code	Function Name	Setting scope	Factory set value
P3.2.01	Intermediate Relay Control Word A	0: Reference 0 1: Reference 1 Ones: M1 Tens: M2 Hundreds: M3 Thousands: M4 Ten Thousands: M5	00000

When which digit of Function Code P3.2.00 is 0, this function Code is used to compulsorily set corresponding relay of this digit at 0 or 1. Refer to 7.1.12 for more details (Simple Internal Relay Programmable Function).

Function code	Function Name	Setting scope	Factory set value
P3.2.02	Intermediate Delay Relay M1 Control Word B	Ones: Control Logic 0: Input 1	00000
P3.2.03	Intermediate Delay Relay M2 Control Word B	1: Input 1 and NOT 2: Input 1 and Input 2 AND	00000
P3.2.04	Intermediate Delay Relay M3 Control Word B	3: Input 1 and Input 2 OR 4: Input 1 and Input 2 XOR	00000
P3.2.05	Intermediate Delay Relay M4 Control Word B	5: the valid reference of Input 1 is valid the valid Reference of Input 2 is invalid	00000
P3.2.06	Intermediate Delay Relay M5 Control Word B	6: Valid reference of Input 1 Rise Edge is valid Valid reference of Input 2 Rise Edge is invalid 7: Reverse valid signal of Input 1 Rising Edge 8: Input 1 Rise Edge is valid and output a impulse signal with width of 200ms 9: Input 1 Rise Edge and Input 2 AND Hundreds and Tens: Input 1 Selection 0~9: DI1~DI10 10~14: M1~M5 15~16: VF1, VF2 17~19: Standby 20~79: Output Function 00~59 Corresponding to Multi-functional Output Terminal Ten Thousands: Input 2 Selection 0~9: DI1~DI10 10~14: M1~M5 15~16: VF1, VF2 17~19: Standby 20~59: Output Function 00~39 Corresponding to Multi-functional Output Terminal	00000

When which digit of Function Code P3.2.00 is 1, the relay of this digit is controlled by the above corresponding function code. The ones of the above function codes are used to set the logic operation function of Input 1 and Input 2. The hundreds and tens are used to set the option for Input 1. Ten Thousands and Thousands are used to set the option for Input 2. The Intermediate Delay Relay M is the result from simple logic operation of Input 1 and Input 2.

M=Logic Operation (Input 1 and Input 2)

Refer to 7.1.12 for more details (Simple Internal Relay Programmable Function)

Function code	Function Name	Setting scope	Factory set value
P3.2.07	Intermediate Delay Relay M1 Control Word C	Tens Ones: 00~59	0000
P3.2.08	Intermediate Delay Relay M2 Control Word C	Output Function 00~59 Corresponding to Digital Input	0000
P3.2.09	Intermediate Delay Relay M3 Control Word C	Terminal Thousands Hundreds: 00~59	0000
P3.2.10	Intermediate Delay Relay M4 Control Word C	Output Function 00~59 Corresponding to	0000
P3.2.11	Intermediate Delay Relay M5 Control Word C	Multi-functional Output Terminal	0000

The tens and ones of the above function codes are used to set the action destination of acquiring the Intermediate Delay Relay after logic operation results, that is, action to be performed ( it can correspond to any one kind of digital input functions), and the thousands and hundreds are used to control corresponding relay when which digit of Function Code P3.2.00 is 2 (it can correspond to any one kind of multi-functional output terminal functions).Refer to 7.1.12 for more details (Simple Internal Relay Programmable Function)

Chapter 6. Description of Parameters

Function code	Function Name	Setting scope	Factory set value
P3.2.12	M1 Connection Delay Time	0.0s~3600.0s	0000.0
P3.2.13	M2 Connection Delay Time	0.0s~3600.0s	0000.0
P3.2.14	M3 Connection Delay Time	0.0s~3600.0s	0000.0
P3.2.15	M4 Connection Delay Time	0.0s~3600.0s	0000.0
P3.2.16	M5 Connection Delay Time	0.0s~3600.0s	0000.0
P3.2.17	M1 Disconnection Delay Time	0.0s~3600.0s	0000.0
P3.2.18	M2 Disconnection Delay Time	0.0s~3600.0s	0000.0
P3.2.19	M3 Disconnection Delay Time	0.0s~3600.0s	0000.0
P3.2.20	M4 Disconnection Delay Time	0.0s~3600.0s	0000.0
P3.2.21	M5 Disconnection Delay Time	0.0s~3600.0s	0000.0

The above function codes are used to set the delay time of connecting or disconnecting the Intermediate Delay Relays.

Function code	Function Name	Setting scope	Factory set value
P3.2.22	Valid State Option of Intermediate Relay	0: Not Negation 1: Negation Ones: M1 Tens: M2 Hundreds: M3 Thousands: M4 Ten Thousands: M5	00000

This function code is used to set valid state of the Intermediate Delay Relay.

If which digit is 0, it means that the relay of this digit will output the signal of acquired results.

If which digit is 1, it means that the relay of this digit will invert the signal of acquired results and output it.

Function code	Function Name	Setting scope	Factory set value
P3.2.23	Internal Timer Control Word	Ones: Timing Control 1 of Timer Tens: Timing Control 2 of Timer 0: Timer Running 1: Controlled by Timer Input Terminal 1 2: Negation Control of Timer Input Terminal 1 3: Controlled by Timer Input Terminal 2 4: Negation Control of Timer Input Terminal 2 Hundreds: Timer 1 Reset Control Thousands: Timer 2 Reset Control 0: Controlled by Timer Reset Terminal 1 1: Controlled by Timer Reset Terminal 2 Ten Thousands: Timing Unit 0: Second 1: Minute 2: Hour	00000

The ones and tens of this function code is used to set the timing control of Timer 1 and Timer 2 respectively.

0: Indicate that the timer is uncontrollable and continuously counting.

1: Conduct control by Timer Input Terminal 1, when this terminal state is valid, the timer starts counting, when the terminal state is invalid, the timer stops counting and keeps current value.

2: Conduct inverse control by Timer Input Terminal 1, when this terminal state is invalid, the timer starts counting, when the terminal state is valid, the timer stops counting and keeps current value.

3~4: Refer to Description for 1 and 2.

The hundreds and thousands of this function code are respectively used to set reset control of Timer 1 and Timer 2.

0: Control by Timer Reset Terminal 1, when this terminal state is valid, the timing value of the timer is recover zero.

1: Control by Timer Reset Terminal 2, when this terminal state is valid, the timing value of the timer is recover zero.

The ten thousands of this function is used to set the timing unit. 0 indicates second, 1 indicates minute and 2 indicates hour respectively.

Refer to the explanation of 7.1.13 (Internal Timer Function).

Function code	Function Name	Setting scope	Factory set value
P3.2.24	Timing Time of Timer 1	0.0s~3600.0s	00000
P3.2.25	Timing Time of Timer 2	0.0s~3600.0s	00000

Function Code P3.2.24 and P3.2.25 are respectively used to set the time of Timer 1 and Timer 2.

Function code	Function Name	Setting scope	Factory set value
P3.2.26	Operation Module Operation Module	0: No Operation 1: Add Operation 2: Subtraction Operation 3: Multiply Operation 4: Division Operation 5: Greater than Judgment 6: Equal to Judgment 7: Equal to or Greater than Judgment 8: Integration 9~F: Reservation Ones: Operation 1 Tens: Operation 2 Hundreds: Operation 3 Thousands: Operation 4	H.0000

The ones, tens, hundreds and thousands of this function code respectively correspond to one-way operation. Each operation can select different operation methods. Refer to the explanation of 7.1.14 for more details (Internal Operation Function).

Function code	Function name	Setting scope	Factory set value
P3.2.27	Operation Setting Coefficient Property	0: Operate the Setting Coefficient by multiplication without decimal 1: Conduct setting at one decimal fraction to system by multiplication algorithm 2: Conduct setting at two decimal fractions to system by multiplication algorithm 3: Conduct setting at three decimal fractions to system by multiplication algorithm 4: Conduct setting at four decimal fractions to system by multiplication algorithm 5: Conduct setting at no decimal fraction to system by division algorithm 6: Conduct setting at one decimal fractions to system by division algorithm 7: Conduct setting at two decimal fractions to system by division algorithm 8: Conduct setting at three decimal fractions to system by division algorithm 9: Conduct setting at four decimal fractions to system by division algorithm A: Conduct setting at one decimal fractions to system by division algorithm B: Conduct setting at two decimal fractions to system by division algorithm C: Conduct setting at three decimal fractions to system by division algorithm D: Conduct setting at four decimal fractions to system by division algorithm (The setting coefficient of A, B, C, D, E is the address number of function code) Ones: Operation 1 Tens: Operation 2 Hundreds: Operation 3 Thousands: Operation 4	0000

The scope of the operation results is not certainly equal to the setting scope of the function codes of the frequency inverter, so a setting coefficient is required to set the scope of the operation results to the setting scope of the function codes of the frequency inverter. When the set value is 0~9, the operation setting coefficient is a number which can be included in operation directly. When the set value is A~E, the operation setting coefficient is a address number of function code and only the number in the address of function code can be included in operation. This function code is used to set the functions of the setting coefficient. The ones, tens, hundreds and thousands of this function code respectively correspond to one-way operation. Refer to the Description of 7.1.14 for more details (Internal Operation Function).

Function code	Function Name	Setting scope	Factory set value
P3.2.28	Input A of Operation 1	Thousands, Hundreds, Tens and Ones: express address of Input A of Operation 1 Ten Thousands: express input operation model 0: Input is operation by unsigned number 1: Input is operation by signed number	00000
P3.2.29	Input B of Operation 1	Thousands, Hundreds, Tens and Ones: express address of Input B of Operation 1 Ten Thousands: express input operation model 0: Input is operation by unsigned number 1: Input is operation by signed number	00000
P3.2.30	Setting Coefficient of Operation 1	00000~65535	00001

The above function codes are used to set input address and setting coefficient of Operation 1. The thousands, hundreds, tens and ones of Function Code P3.2.28 and Function Code P3.2.29 represent the address of Input A of Operation 1 and Input B of Operation 1 respectively. The input address corresponds to all function codes, e.g. Address 0005 corresponds to Function Code P0.0.05. If the input address has no corresponding function code, the default value in the input address is 0. The ten thousands in P3.2.28 and P3.2.29 indicate the operation mode of the digital value in input address. 0 means the operation by unsigned number and 1 means the operation by signed number.

Function Code P3.2.30 is used to set the setting coefficient of Operation 1. When the ones unit of P3.2.27 is set to 0~9, the numbers in function code P3.2.30 can be included in operation directly; when the ones unit of P3.2.27 is set to A ~ E, only the numbers which are the address numbers of function code P3.2.30 can be included in operation, namely indirect addressing.

Function code	Function name	Setting scope	Factor y set value
P3.2.31	Input A of Operation 2	Thousands, Hundreds, Tens and Ones: express address of Input A of Operation 2 Ten Thousands: express input operation model 0: Input is operation by unsigned number 1: Input is operation by signed number	00000
P3.2.32	Input B of Operation 2	Thousands, Hundreds, Tens and Ones: express address of Input B of Operation 1 Ten Thousands: express input operation model 0: Input is operation by unsigned number 1: Input is operation by signed number	00000
P3.2.33	Setting Coefficient of Operation 2	00000~65535	00001
P3.2.34	Input A of Operation 3	Thousands, Hundreds, Tens and Ones: express address of Input A of Operation 3 Ten Thousands: express input operation model 0: Input is operation by unsigned number 1: Input is operation by signed number	00000
P3.2.35	Input B of Operation 3	Thousands, Hundreds, Tens and Ones: express address of Input B of Operation 3 Ten Thousands: express input operation model 0: Input is operation by unsigned number 1: Input is operation by signed number	00000
P3.2.36	Setting Coefficient of Operation 3	00000~65535	00001
P3.2.37	Input A of Operation 4	Thousands, Hundreds, Tens and Ones: express address of Input A of Operation 4 Ten Thousands: express input operation model 0: Input is operation by unsigned number 1: Input is operation by signed number	00000
P3.2.38	Input B of Operation 4	Thousands, Hundreds, Tens and Ones: express address of Input B of Operation 4 Ten Thousands: express input operation model 0: Input is operation by unsigned number 1: Input is operation by signed number	00000
P3.2.39	Setting Coefficient of Operation 4	00000~65535	00001

The above function codes are used to set the input address and setting coefficient of Operation 2, 3, 4. Refer to the explanation of Function Code P3.2.28~P3.2.30 for more details.

## 6.5 GROUP P4 PID CONTROL AND COMMUNICATION CONTROL

## P4.0 PID Control Group

Function code	Function Name	Setting scope	Factory set value
P4.0.00	PID Reference Source	0: Digital Reference (P4.0.01) 1: Keyboard Potentiometer Reference 2: External Terminal VF1 Reference 3: External Terminal VF2 Reference 4: PULS Reference (DI6) 5: Communication Reference 6: Multiplex Directive Terminal Reference 7: Simple PLC Reference 8: Operation Result 1 9: Operation Result 2 10: Operation Result 3 11: Operation Result 4	00

## 0: Digital Reference (P4.0.01)

PID Reference Value is determined by the value by Function Code P4.0.01.

## 1: Keyboard Potentiometer Reference

PID Reference Value is determined by Keyboard Potentiometer.

## 2: External Terminal VF1 Reference

## 3: External Terminal VF2 Reference

PID Reference Value is set by the analog input terminal. E Series Frequency inverter provides 2-way analog input terminal (VF1, VF2). VF1 and VF2 can input 0V~10V voltage or 0/4mA~20mA current. As for corresponding relation curve between the input value of VF1 and VF2 and PID value, the users can freely choose from four kinds of the relation curves through function code P2.1.02, in which Curve 1 and Curve 2 are linear relationship able to be set through Function Code P2.0.13~P2.0.22, and Curve 3 and Curve 4 are broken line relationship with two inflection points able to be set through Function Code P2.1.04~P2.1.19. The deviation between actual voltage and sampling voltage of the analog input terminal can be adjusted through Function Code P8.1.05~P8.1.12.

## 4: PULS Reference (DI6)

PID Reference Value is set by high-speed impulse frequency of digital input terminal DI6 (the terminal function is not defined). The corresponding relationship between high-speed impulse frequency and PID value can be set through Function Code P2.0.23~P2.0.26, that is, linear relationship.

## 5: Communication Reference

PID Reference Value is set by the upper computer through communication mode (refer to Chapter VIII for more details).

## 6: Multiplex Directive Terminal Reference

PID Reference Value is given by different composite state of Multiplex Directive Terminal. E Series Frequency inverter is able to set four Multiplex Directive Terminals (Terminal Function 9~12, refer to the explanation for Multiplex Directive Terminal Function of P2.0.00~P2.0.09 for more details)

## 7: Simple PLC Reference

PID Reference Value is given by Simple PLC Function, PID Reference of the frequency inverter can be switched among 1~16 arbitrary frequency directives, the sources, hold time and acceleration & deceleration time of each frequency directive can be set through Function Code 3.0.03~P3.0.50.

## 8: Operation Result 1

## 9: Operation Result 2

## 10: Operation Result 3

## 11: Operation Result 4

PID Reference Value is determined by the operation results after setting calculation of the internal operation module. Refer to the Description of Function Code P3.2.26~P3.2.39 for more details of the operation module. The operation results can be viewed through Function Code 9.0.46~P9.0.49.

Function code	Function Name	Setting scope	Factory set value
P4.0.01	PID Value Reference	000.0%~100.0%	050.0%

When at Function Code P4.0.00=0, PID Reference is determined by the value set by this function code.

Function code	Function Name	Setting scope	Factory set value
P4.0.02	PID Feedback Source	0: External Terminal VF1 Reference 1: External Terminal VF2 Reference 2: VF1-VF2 3: VF1+VF2 4: PULS Reference (DI6) 5: Communication Reference 6: MAX[VF1, VF2] 7: MIN[VF1, VF2] 8: Switch of Multiplex Directive Terminal on the above conditions 9: Operation Result 1 10: Operation Result 2 11: Operation Result 3 12: Operation Result 4	00

0: External Terminal VF1 Reference

1: External Terminal VF2 Reference

PID Feedback Value is set by the analog input terminal.

2: VF1-VF2

PID Feedback Value is set by the analog VF1-VF2 input.

3: VF1+VF2

PID Feedback Value is set by the analog F1+VF2 input.

4: PULS Reference

PID Reference Value is set by high-speed impulse frequency of digital input terminal DI6 (the terminal function is not defined). The corresponding relationship between high-speed impulse frequency and corresponding PID value can be set through Function Code P2.0.23~P2.0.26, that is, linear relationship.

5: Communication Reference

PID Reference Value is set by the upper computer through communication mode (refer to Chapter VIII for more details).

6: MAX[VF1, VF2]

PID Feedback Source is set by maximum value between Analog VF1 and VF2 Input.

7: MIN[VF1, VF2]

PID Feedback Source is set by minimum value between Analog VF1 and VF2 Input.

8: Multiplex directive terminal switches among the above among the above conditions

PID Reference Value switches among the above 8 kinds of conditions by different composite state of Multiplex Directive Terminal. E Series Frequency inverter is able to set four Multiplex Directive Terminals, when in use, it is to take three terminal functions (Terminal Function 9~11), refer to the table below for more details:

Terminal 3	Terminal 2	Terminal 1	Feedback channel
0	0	0	VF1 (correspond to P4.0.02=0)
0	0	1	VF2 (correspond to P4.0.02=1)
0	1	0	VF1-VF2 (correspond to P4.0.02=2)
0	1	1	VF1+VF2 (correspond to P4.0.02=3)
1	0	0	PULS reference (correspond to P4.0.02=4)
1	0	1	Communication Reference (correspond to P4.0.02=5)
1	1	0	MAX[VF1, VF2] (correspond to P4.0.02=6)
1	1	1	MIN[VF1, VF2] (correspond to P4.0.02=7)

9: Operation Result 1

10: Operation Result 2

11: Operation Result 3

12: Operation Result 4

PID Reference Value is determined by the operation results after setting calculation of the internal operation module. Refer to the explanation of Function Code P3.2.26~P3.2.39 for more details of the operation module. The operation results can be viewed through Function Code 9.0.46~P9.0.49.

Function code	Function Name	Setting scope	Factory set value
P4.0.03	PID Action Direction	0: Direct Action 1: Reverse Action	0

This function code is used to set the change conditions of the frequency with the feedback quantity.

0: Direct Action

The output frequency of the frequency inverter is in proportion to its feedback quantity, when the feedback quantity is less than the given quantity, the output frequency of the frequency inverter rises to make the feedback quantity rise accordingly and final feedback quantity equal to the given quantity.

1: Reverse Action

The output frequency of the frequency inverter is in inverse proportion to its feedback quantity, when the feedback quantity is greater than the given quantity, the output frequency of the frequency inverter rises to make the feedback quantity decline accordingly and final feedback quantity equal to the given quantity.

Function code	Function Name	Setting scope	Factory set value
P4.0.04	PID Reference Feedback Range	00000~65535	01000

The feedback range of PID Reference is dimensionless unit, which is the range of PID Reference showing P9.0.14 and PID Feedback showing P9.0.15. If P4.0.04 is set at 5000, when the feedback value of PID is 100.0%, PID Feedback showing P9.0.15 is 5000. PID Reference and Feedback are set based on this parameter.

Function code	Function Name	Setting scope	Factory set value
P4.0.05	Proportional Gains KP1	000.0~100.0	020.0
P4.0.06	Integral Time TI1	00.01s~10.00s	02.00
P4.0.07	Derivative Time TD1	00.000s~10.000s	00.000

The greater the value of proportional gain KPI is, the larger the adjustment volume is and the faster the response is, but the too large value can generate the system oscillation, the smaller the value of KPI is, the more stable the system is and the slower the response is.

The greater the value of Integral Time TI1 is, the slower the response is and the more stable the output is, the worse the fluctuation control ability of the feedback quantity is, the smaller the value of TI1 is, the faster the response is and the greater the output fluctuation is, the too small value can generate the oscillation.

The Derivative Time TD1 can set the limit for gain provided by the derivator to ensure that a pure derivative gain can be obtained at low frequency and a constant derivative gain can be obtained at high frequency. The longer the derivative time is, the greater the adjusting strength is.

Function code	Function Name	Setting scope	Factory set value
P4.0.08	PID Deviation Limit	000.0%~100.0%	000.0

This function code is used to determine whether PID is adjusted to prevent unstable output frequency when the deviation between reference and feedback is small.

When the deviation between reference quantity and feedback quantity is less than the value set by P4.0.08, stop the adjustment to PID and the frequency inverter keeps stable output.

When the deviation between reference quantity and feedback quantity is greater than the value set by P4.0.08, adjust PID.

Function code	Function Name	Setting scope	Factory set value
P4.0.09	PID Feedback Filtering time	00.00~60.00s	00.00

VF1 Input Filtering time is used to set the software filtering time of VF1, when the on-site analog is easily to be disturbed, the filtering time shall be increased to make the tested analog trend to be stable, but the greater filtering time makes the response speed of the analog test become slow, so how to balanceset needs is based on actual situations of the applications.

Function code	Function Name	Setting scope	Factory set value
P4.0.10	Proportional Gains KP2	000.0~100.0	020.0
P4.0.11	Integral Time TI2	00.01s~10.00s	02.00
P4.0.12	Derivative Time TD2	00.000s~10.000s	00.000

The above function codes have the same functions with Function Code P4.0.05~P4.0.07, refer to the Description for P4.0.05~P4.0.07.

Function code	Function Name	Setting scope	Factory set value
P4.0.13	PID Switch Conditions	0: No Switch 1: Switch through Terminals 2: Switch through Deviation	0

In some occasions of special applications, better PID Parameter is required to be adopted for control under different conditions. This function code is used to set under what condition PID Parameter is required to be switched.

0: No Switch

Adopt PID parameters of P4.0.05~P4.0.07 by default.

1: Switch through Terminal

The switch is made through digital input terminal (set this terminal function at 41: switch of PID parameter). When the terminal signal is valid, adopt PID parameters of P4.0.05~P4.0.07. When the terminal signal is valid, adopt PID parameters of this group of P4.0.10~P4.0.12.

2: Switch based on Deviation

The switch is made based on set value of Function Code P4.0.14 and P4.0.15, refer to the Description of Function Code P4.0.14 and P4.0.15.

Function code	Function Name	Setting scope	Factory set value
P4.0.14	PID Switch Deviation 1	000.0%~P4.0.15	020.0
P4.0.15	PID Switch Deviation 2	P4.0.14~100.0%	080.0

When at P4.0.13=2, it is to determine whether the switch of PID parameters needs to be done through these two function codes. The set value of these two function codes is the percentage relative to Function Code P4.0.04 (PID Reference Feedback Range).

When the deviation between reference and feedback is less than PID Switch Deviation 1, adopt PID Parameter of P4.0.05~P4.0.07. When the deviation between reference and feedback is greater than PID Switch Deviation 2, adopt PID Parameter of P4.0.10~P4.0.12. When the deviation between reference and feedback is between PID Switch Deviation 1 and PID Switch Deviation 2, PID Parameter is the linear interpolation value of these two groups of PID Parameters, refer to the description of the figure below:

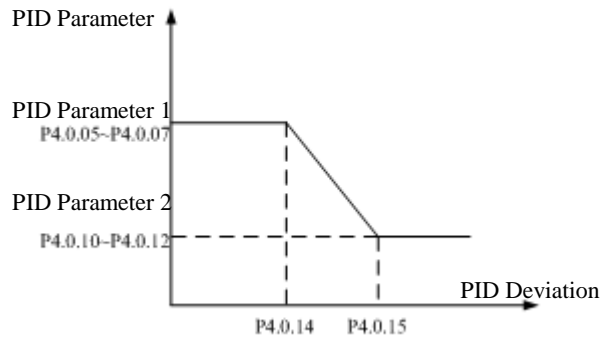

Function code	Function Name	Setting scope	Factory set value
P4.0.16	PID Initial Value	000.0%~100.0%	000.0
P4.0.17	PID Initial Value Hold Time	000.00~650.00s	000.00

When the frequency inverter starts, first speed it up to initial value of PID at acceleration time and then keep running at initial state of PID, after the duration of time reaches the time given by P4.0.17, conduct regulation to PID. Initial Value of PID is the percentage relative to the highest frequency, refer to the description of the figure below:

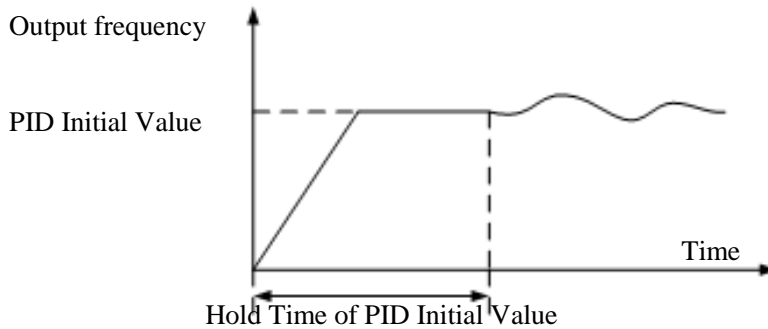

Function code	Function Name	Setting scope	Factory set value
P4.0.18	PID Feedback Loss Test	000.0%: No Judgment on Feedback Loss 000.1%~100.0%	000.0
P4.0.19	PID Feedback Loss Test Time	00.0s~20.0s	00.0

These two function codes are used to judge whether the feedback signal of PID is missing.

When at P4.0.18=0.0%, no judgment is made for whether the feedback signal of PID is missing.

When at P4.0.18>0.0%, actual PID Feedback Value is less than the value given by P4.0.18 and the duration of time exceeds the time given by P4.0.19, the frequency inverter gives an alarm of Err20 Fault, it is deemed that the feedback signal of PID is missing

Function code	Function Name	Setting scope	Factory set value
P4.0.20	PID Stop Operation	0: No Operation 1: Operation	0

This function code is used to set whether PID operates when the frequency inverter is in shutdown state.

0: No Operation

When the frequency inverter runs, PID operates; when the frequency inverter shuts down, PID can't operate (choose this under general conditions)

1: Operation

No matter what the state of the frequency inverter is, running state or shutdown state, PID operates.

## P4.1 Communication Group

Function code	Function Name	Setting scope	Factory set value
P4.1.00	Baud Rate	0: 1200 1: 2400 2: 4800 3: 9600 4: 19200 5: 38400 6: 57600	3
P4.1.01	Data Format	0: No Verification (8-N-2) 1: Even Parity Verification (8-E-1) 2: Odd Parity Verification (8-O-1) 3: No Verification (8-N-1)	0
P4.1.02	Local Machine Address	000: Broadcast Address 001~249	001
P4.1.03	Response Delay	00~20ms	02
P4.1.04	Communication Timeout	00.0 (Invalid) 00.1s~60.0s	00.0
P4.1.05	Data Transmission Format	0: ASCII Mode (Reservation) 1: RTU Mode	1

When E Series inverter realizes the communication with other equipments through communication terminal RS-485, it is required to set the above function codes. Refer to Communication RS-485 of E Series Frequency inverter in Chapter VIII for more details.

## 6.6 Group P5 Keyboard Display

## P5.0 Basic Group

Function code	Function Name	Setting scope	Factory set value
P5.0.00	Keyboard JOG Key Function Reference	0: Invalid 1: Forward Jogging 2: Reverse Jogging 3: Forward and Reverse Switch	1

This function code is used to set the function of Multi-functional Key JOG.

When at P5.0.00=0, the function of Key JOG is invalid

When at P5.0.00=1, the function of Key JOG is forward jogging function

When at P5.0.00=2, the function of Key JOG is reverse jogging function

When at P5.0.00=3, the function of Key JOG is forward and reverse switch function

**Note: Forward Jogging Function and Reserve Jogging Function are valid under any running control mode, but the forward and reverse switch function is only valid under keyboard control mode (i.e. P0.0.03=0)**

Function code	Function Name	Setting scope	Factory set value
P5.0.01	Keyboard STOP Key Stop Function	0: Only valid in keyboard operation mode 1: Valid for any mode	1

This function code is used to set shutdown function of Key Stop.

When at P5.0.01=0, the shutdown function is only valid under Keyboard Control Mode (i.e. P0.0.03=0)

When at P5.0.01=1, the shutdown function is valid under any running control modes.

**Note : The fault reset function is always valid.**

Function code	Function Name	Setting scope	Factory set value
P5.0.02	LED Running Display Parameter 1	H.0001~H.FFFF	H.001F
P5.0.03	LED Running Display Parameter 2	H.0000~H.FFFF	H.0000
P5.0.04	Automatic Time Switch of LED Running Display Parameter	000.0: No Switch 000.1s~100.0s	000.0

Function Code P5.0.02 and P5.0.03 determine the contents displayed by LED when the frequency inverter is at running state.

Function Code P5.0.04 determines the length of time that displays Parameter 1 and Parameter 2. When setting this to 0, only shown the display parameter given by P5.0.02, or it is to switch between display parameter set by P5.0.02 and display parameter set by P5.0.03 based on the Reference Time.

The format for specific display contents is as below:

Running Display Parameter 1 of LED																
15	14	13	12	11	10	9	8	7	6	5	4	3	2	1	0	Running Frequency (Hz)
																Set Frequency (Hz)
																Output Current (A)
																Output Voltage (V)
																Bus line voltage (V)
																Output Torque (%)
																Output Power (kW)
																Output Terminal State
																Input Terminal State
																VF1 Voltage (V)
																VF2 Voltage (V)
																Customized Display Value
																Actual counting value (m)
																PID Set
																PID Feedback
In operation, if it is required to display each parameter above, set corresponding position to 1, after transfer binary system to hexadecimal system, set at P5.0.02.																
Running Display Parameter 2 of LED																
15	14	13	12	11	10	9	8	7	6	5	4	3	2	1	0	PULSE Impulse Frequency (kHz)
																Feedback Speed (Hz)
																PLC Stage (A)
																Voltage before VF1 Correction (V)
																Voltage before VF2Correction (V)
																Line Speed (m/min)
																Current Power-on Time (min)
																Current Running Time (min)
																Residual Running Time (min)
																Frequency Source A (Hz)
																Frequency Source B (Hz)
																Communication Set value (%)
																PULSE Impulse Frequency (Hz)
																Encoder Feedback Speed (Hz)
																Actual Speed Value
																User Standby Monitoring Value 1
In operation, if it is required to display each parameter above, set corresponding position to 1, after transfer binary system to hexadecimal system, set at P5.0.03.																

Function code	Function name	Setting scope	Factory set value
P5.0.05	LED Shutdown Display Parameter	H.0001~H.FFFF	H.0033

This function code determines the contents displayed by LED when the frequency inverter is at shutdown state.

The format for specific display contents is as below:

Stopping Display Parameter of LED																
15	14	13	12	11	10	9	8	7	6	5	4	3	2	1	0	Reference Frequency (Hz)
																Bus line voltage (V)
																Input Terminal State
																Output Terminal State
																VF1 Voltage (V)
																VF2 Voltage (V)
																Actual Count Value
																Actual Length Value (m)
																PLC Stage
																User-defined Display Value
																PID Reference
																PID Feedback
																PULSE Impulse Frequency (Hz)
																User Standby Monitoring Value 1
																Reservation
																Reservation

In shutdown state, if the above parameters are required to display, the corresponding position is set at 1, after the binary digit is converted into hexadecimal digit, it is set at P5.0.05.

Function code	Function Name	Setting scope	Factory set value
P5.0.06	LCD Line 1 Display at Running	0000~9399	9001
P5.0.07	LCD Line 2 Display at Running	0000~9399	9000
P5.0.08	LCD Line 3 Display at Running	0000~9399	9002
P5.0.09	LCD Line 4 Display at Running	0000~9399	9003

The above function codes are used to set the contents displayed by each line when the frequency inverter adopts LCD Keyboard at running state. The value given by P5.0.06~P5.0.09 is the parameter address required to display, e.g. if the reference value of Parameter P9.0.00 is needed to display in operation, it is to set one reference value of P5.0.06~P5.0.09 to 9000.

Function code	Function Name	Setting scope	Factory set value
P5.0.10	LCD Line 1 Display at stop	0000~9399	9001
P5.0.11	LCD Line 2 Display at stop	0000~9399	9000
P5.0.12	LCD Line 3 Display at stop	0000~9399	9004
P5.0.13	LCD Line 4 Display at stop	0000~9399	0000

The above function codes are used to set the contents displayed by each line when the frequency inverter adopts LCD Keyboard at shutdown state. The value given by P5.0.10~P5.0.13 is the parameter address required to display, e.g. if the reference value of Parameter P9.0.01 is needed to display when shut down, it is to set one reference value of P5.0.10~P5.0.13 to 9001.

Function code	Function name	Setting scope	Factory set value
P5.0.14	LCD Chinese/English Display Switch	0: Chinese 1: English	0

When the above function codes are used to set either Chinese Display or English Display when the frequency inverter adopts LCD Keyboard.

Function code	Function name	Setting scope	Factory set value
P5.0.15	Customized Display of Coefficient	0.0001~6.5000	1.0000
P5.0.16	User-defined Display control word.	<p>Ones unit: user-defined decimal place displaying            0: 0-digit Decimal Point            1: 1-digit Decimal Point            2: 2-digit Decimal Point            3: 3-digit Decimal Point            Tens unit: source of user-defined display value            0: determined by hundreds place of user-defined Display control word.            1: determined by set value of P5.0.15, and 0.0000 ~ 0.0099 corresponding to P9.0.00 ~ P9.0.99 of P9 Group.            Hundreds unit: selection of user-defined displaying coefficient            0: user-defined displaying coefficient is P5.0.15.            1: user-defined displaying coefficient is calculation result 1            2: user-defined displaying coefficient is calculation result 2            3: user-defined displaying coefficient is calculation result 3            4: user-defined displaying coefficient is calculation result 4</p>	001

In some conditions, the users want to let the frequency inverter not display the frequency, but some values that have linear relationship with frequency. The users can adjust the corresponding relation between display value and frequency of the frequency inverter through modification to Function Code P5.0.15, P5.0.16. This display value is called user-defined display value. Additionally, if want to display any parameter of Group P9, it can be modified through P5.0.15 & P5.0.16.

The ones unit of P5.0.16 is used to set up the decimal places of user-defined display value.

The tens unit of P5.0.16 is used to set up the source of user-defined display value. If set up to 0, display value will be a number in relation with frequency; if set up to 1, display value will be a number in relation with P9 Group, see details as follows:

Tens unit of P5.0.16	Display control word	Description	
0	Hundreds unit of P5.0.16	0	Display value = Frequency × P5.0.15
		1	Display value = Frequency × Calculation Result 1 ÷ 10000
		2	Display value = Frequency × Calculation Result 2 ÷ 10000
		3	Display value = Frequency × Calculation Result 3 ÷ 10000
		4	Display value = Frequency × Calculation Result 4 ÷ 10000
1	P5.0.15	The set value 0.0000~0.0099 of P5.0.15 corresponds to P9.0.00~P9.0.99 of P9 Group. Example: if P5.0.15=0.0002, display value is the value of P9.0.02.	
Note: places of decimal of user-defined decimal are not considered for the above operation			

Example: The user-defined displaying coefficient of P5.0.15 is 0.5000, the user-defined display control word of P5.0.16 is 003, and the frequency is 20.00Hz, the user-defined display value shall be  $2000 \times 0.5000 = 1.000$  (display three decimal places).

If the user-defined display control word of P5.0.16 is 003, and the frequency is 20.00Hz, the user-defined display value shall be  $2000 \times 0.5000 = 1.000$  (display three decimal places).

If user-defined control word P5.0.16 is 013, P5.0.15 is 0.0002 and P9.0.02=1000, the user-defined display value is 1.000 (display three decimal places).

Function code	Function name	Setting scope	Factory set value
P5.0.17	Selection of Function Group Display of Parameter	Ones: 0: Only display basic group 1: Display the menus at all levels Tens 0: Don't display Group P7 1: Display Group P7 2: Reservation Hundreds: 0: Don't display correction parameter group 1: Display correction parameter group Thousands: 0: Don't display code group 1: Display code group Ten Thousands: Reservation	00011

When the function code is at P0.0.01=0, its function determine what the parameters of the function code is displayed in detail.

Function code	Function name	Setting scope	Factory set value
P5.0.18	Function Password Protection	0: Modifiable 1: Non-modifiable 2: Allowable Modification to GP Type	0

This function code is used to set whether the parameters of the frequency inverter can be modified.  
 When at P5.0.18=0, the parameters of all function codes can be modified;  
 When at P5.0.18=1, the parameters of all function codes can only be viewed but not be modified, such a way can effectively prevent the parameters of the function from incorrect modification.  
 When at P5.0.18=2, Function Code P0.0.00 is allowed to modify.

Function code	Function name	Setting scope	Factory set value
P5.0.19	Parameter Initialization	00: No Operation 01: Clearance of Record Information 09 Recover Factory set value, excluding motor parameter, correction group, password group 19: Recover Factory set value, excluding motor parameter, password group 30: Users Current Parameter Backup 60: User Backup Parameters Recovery 100~999: User factory set values recovery	000

0: No Operation

1: Clearance of Record Information

Clear fault record information, accumulative running time, accumulative power-on time and accumulative power consumption of the frequency inverter

9: Recover factory set value, excluding motor parameter, correction group, password group

The frequency inverter resets to factory set value, excluding motor parameter, correction group, password group.

19: Recover Factory set value, excluding motor parameter, password group

The frequency inverter resets to factory set value, excluding motor parameter, password group.

30: Users Current Parameter Backup

Back up all current function parameters of the users to the memory, after the parameters adjustment in disorder,

the user can easily reset the disordered parameters to backup function parameters.

#### 60: User Backup Parameters Recovery

Recover the backup user parameters last time, i.e. recover the parameters that are backed up last time when P5.0.19 is set at 30.

#### 100~999: User factory set values recovery

This function is used to reset special tailor-made factory set value of the users. Generally, the users cannot conduct operation to this reset.

Function code	Function name	Setting scope	Factory set value
P5.0.20	User Password	00000~65535	00000

P5.0.20 is the user password reference, that is, any non-zero five digits, the password protection function becomes effective. When enter into the menu next time, if display “----”, input correct password and then view and modify the function parameters. P5.0.20 parameter has modification enable control. Only when P5.0.18 parameter is equal to 2, P5.0.20 can be changed.

If you want to cancel the password protection, only use the password to enter into system and then change P5.0.20 into 00000, the password protection function becomes invalid.

#### P5.1 Expansion Group

Function code	Function name	Description of parameter	Display scope
P5.1.00	Accumulative Running Time	Display accumulated running time of frequency inverter	0h~65000h
P5.1.01	Accumulative Power On Time	Display accumulated electrifying time of frequency inverter since exworks	0h~65000h
P5.1.02	Accumulative Power Consumption	Display accumulated power consumption of frequency inverter up to now	0~65000
P5.1.03	Module Temperature	Display current temperature of the module	000°C~100°C
P5.1.04	Hardware Version No.	Hardware version number	180.00
P5.1.05	Software Version No.	Software version number	001.00
P5.1.06	Program Nonstandard Label	Version number of dedicated program	0000~9999

6.7 Fault Display and Protection Control Group P6

P6.0 Fault Display Group

Function code	Function name	Setting scope	Factory set value
P6.0.00	Fault Record 1 (Last Time)	0~40	00
P6.0.01	Fault Record 2	0~40	00
P6.0.02	Fault Record 3	0~40	00

The above function codes record the fault types in the last three times, 0 indicates no fault. Concerning possible cause of each fault code and solutions, refer to related explanation of Chapter IX.

Function code	Function name	Description for Parameters												
P6.0.03	Fault Frequency 1	Frequency of the fault in the last time												
P6.0.04	Fault Current1	Current of the fault in the last time												
P6.0.05	Bus line voltage 1 when at Fault	Bus line voltage of the fault in the last time												
P6.0.06	Input Terminal State 1 when at fault	Input terminal state of the fault in the last time with the sequence as below <table border="1" style="display: inline-table; vertical-align: middle;"> <tr> <td>VF2</td><td>VF1</td><td>DI10</td><td>DI9</td><td>DI8</td><td>DI7</td><td>DI6</td><td>DI5</td><td>DI4</td><td>DI3</td><td>DI2</td><td>DI1</td> </tr> </table> When the input terminal is ON and its corresponding binary digit is 1. OFF is 0, it is to convert binary digit into denary digit.	VF2	VF1	DI10	DI9	DI8	DI7	DI6	DI5	DI4	DI3	DI2	DI1
VF2	VF1	DI10	DI9	DI8	DI7	DI6	DI5	DI4	DI3	DI2	DI1			
P6.0.07	Output Terminal State 1 when at fault	Input terminal state of the fault in the last time with the sequence as below <table border="1" style="display: inline-table; vertical-align: middle;"> <tr> <td>M5</td><td>M4</td><td>M3</td><td>M2</td><td>M1</td><td>YO2</td><td>YO1</td><td>T2</td><td>T1</td><td>YO</td> </tr> </table> When the input terminal is ON and its corresponding binary digit is 1. OFF is 0, it is to convert binary digit into denary digit.	M5	M4	M3	M2	M1	YO2	YO1	T2	T1	YO		
M5	M4	M3	M2	M1	YO2	YO1	T2	T1	YO					
P6.0.08	Frequency inverter State 1 when at fault	Use of manufacturer												
P6.0.09	Power-on Time 1 when at fault	Current power-on time of the fault in the last time												
P6.0.10	Running Time 1 when at fault	Current running time of the fault in the last time												
P6.0.11	Fault Frequency 2	Same as P6.0.03~P6.0.10												
P6.0.12	Fault Current2													
P6.0.13	Bus line voltage 2 when at Fault													
P6.0.14	Input Terminal State 2 when at fault													
P6.0.15	Output Terminal State 2 when at fault													
P6.0.16	Frequency inverter State 2 when at fault													
P6.0.17	Power-on Time 2 when at fault													
P6.0.18	Running Time 2 when at fault													
P6.0.19	Fault Frequency 3													
P6.0.20	Fault Current3													
P6.0.21	Bus line voltage 3 when at Fault	Same as P6.0.03~P6.0.10												
P6.0.22	Input Terminal State 3 when at fault													
P6.0.23	Output Terminal State 3 when at fault													
P6.0.24	Frequency inverter State 3 when at fault													
P6.0.25	Power-on Time 3 when at fault													
P6.0.26	Running Time 3 when at fault													

## P6.1 Protection Control Group

Function code	Function Name	Setting scope	Factory set value
P6.1.00	Input Default Phase Protection	0: Prohibited 1: Allowed	1

This function code is used to set whether the frequency inverter protects the input default phase.

When at P6.1.00=0, the frequency inverter can't provide protection to input default phase.

When at P6.1.00=1, if the input default phase or three-phase input imbalance is detected out, the frequency inverter gives an alarm of Fault Err11. The allowable degree of three-phase input imbalance is determined by Function Code P6.1.26, the higher the value is, the duller the response is and the higher the allowed degree of three-phase imbalance is. Attention shall be paid that if the frequency inverter cannot operate or the load of the motor is lighter, even the set value of P6.1.26 is set smaller, it is possible that no alarm is given.

Function code	Function Name	Setting scope	Factory set value
P6.1.01	Output Default Phase Protection	0: Prohibited 1: Allowed	1

This function code is used to set whether the frequency inverter protects the output default phase.

When at P6.1.01=0, the frequency inverter can't provide protection to output default phase.

When at P6.1.01=1, if the output default phase or three-phase input imbalance is detected out, the frequency inverter gives an alarm of Fault Err12.

Function code	Function Name	Setting scope	Factory set value
P6.1.02	Overvoltage Stall Protection Sensitivity	000: without protection to overvoltage and stalling speed 001~100	000
P6.1.03	Overvoltage Stall Protection Sensitivity	120%~150%	130

In the deceleration process of the frequency inverter, after the DC Bus line voltage exceeds over-voltage stall protection voltage point, the frequency inverter stops reducing the speed and keeps current running frequency until the Bus line voltage is reduced to below over-voltage stall protection voltage point and then the frequency inverter continues to reduce the speed. The set value of Function Code P6.1.03 is the percentage relative to normal Bus line voltage.

Over-voltage stall protection sensitivity is used to adjust the ability of the frequency inverter on suppressing the overvoltage. The higher this value is, the stronger the ability of suppressing the overvoltage is.

Function code	Function Name	Setting scope	Factory set value
P6.1.04	Overvoltage Stall Protection Voltage Point	000: without protection to overcurrent and stalling speed 001~100	020
P6.1.05	Overcurrent Stall Protection Sensitivity	100%~200%	150

In the acceleration and deceleration process of the frequency inverter, after the output current exceeds the overcurrent stall protection current, the frequency inverter stops the acceleration and deceleration process and keeps current running frequency, and then continues to accelerate and decelerate after the decline of the output current. The set value of the function code P6.1.05 is the percentage relative to rated current of the motor.

The Overcurrent Stall Protection Sensitivity is used to adjust the capability of the frequency inverter on restraining the overcurrent in its acceleration and deceleration process. The greater this value is, the stronger the capability of restraining the overcurrent is, under the precondition that no overcurrent fault occurs, the smaller the set value is, and the better it is.

Function code	Function Name	Setting scope	Factory set value
P6.1.06	Fault Auto Reset Number	00: no auto-reset under failure 01~20	00
P6.1.07	Waiting Interval Time of Fault Auto Reset	000.1s~100.0s	001.0

When at P6.1.06=0, the frequency inverter keeps fault state for there is no automatic fault reset function.

When at P6.1.06>0, the frequency inverter selects the times of automatic fault reset. In case of exceeding the selected times, the frequency inverter keeps fault state.

Function P6.1.07 refers to the waiting time from fault alarm of the frequency inverter to automatic fault reset.

Function code	Function Name	Setting scope	Factory set value
P6.1.08	Fault Protective Action Selection 1	0: Free Stop 1: Stop by its Mode 2: Continuous Running Ones: Motor Overload Tens: Input Default Phase Hundreds: Output Default Phase Thousands: External Default Ten Thousands: Communication Abnormality	00000
P6.1.09	Fault Protective Action Selection 2	0: Free Stop 1: Stop by its Mode 2: Continuous Running Ones: Motor Overload Tens: Feedback Loss Hundreds: User Customerized Fault 1 Thousands: User Customerized Fault 2 Ten Thousands: Power-on Time Reached	00000
P6.1.10	Fault Protective Action Selection 3	Ones: Running Time Reached 0: Free Stop 1: Stop by its Mode 2: Continuous Running Tens: Encoder Abnormality 0: Free Stop Hundreds: Parameter Read-Write Abnormity 0: Free Stop 1: Stop by its Mode Thousands: Motor Overhear 0: Free Stop 1: Stop by its Mode 2: Continuous Running Ten Thousands: Fault of 24V Power Supply 0: Free Stop 1: Stop by its Mode	00000
P6.1.11	Fault Protective Action Selection 4	0: Free Stop 1: Stop by its Mode 2: Continuous Running Ones: Larger Speed Deviation Tens: Motor Overspeed Hundreds: Initial Position Error Thousands: Reservation Ten Thousands: Reservation	00000

The function codes P6.1.08~P6.1.11 are used to set the actions of the frequency inverter after fault alarm. Each digit among the options for fault protection action corresponds to a kind of fault protection, if it is 0, it indicates that the frequency inverter stops freely; if it is 1, it indicates that the frequency inverter shuts down in stop mode after fault alarm; if it is 2, it indicates that the frequency inverter continues to run at frequency selected by Function Code P6.1.12 after fault alarm.

Function code	Function Name	Setting scope	Factory set value
P6.1.12	Continuous Running Frequency Selection when at Fault	0: Running at Current Frequency 1: Running at Reference frequency 2: Running at Upper Frequency 3: Running at Lower Frequency 4: Running at Back Frequency for Abnormality	0

When the frequency inverter breaks down in the running process, if the handling mode of this fault is continuous running, the frequency inverter displays A\*\* (A\*\* is its fault code), it continues to run at frequency selected by P6.1.12. If the handling mode of this fault is shut-down by reducing the speed, the frequency inverter displays A\*\* in the process of deceleration, the stop state display Err\*\*.

0: Run at Current Frequency

When the frequency inverter gives an alarm of fault, run at current frequency

1: Run at Reference Frequency

When the frequency inverter gives an alarm of fault, run at reference frequency

2: Run at Upper Frequency

When the frequency inverter gives an alarm of fault, run at upper frequency

3: Run at Lower Frequency

When the frequency inverter gives an alarm of fault, run at lower frequency

4: Run at Standby Frequency for Abnormality

When the frequency inverter gives an alarm of fault, run at frequency set by Function Code P6.1.13.

Function code	Function Name	Setting scope	Factory set value
P6.1.13	Backup Frequency for Abnormality	000.0%~100.0%	100.0

When at Function Code P6.1.12=4, the set value of this function code determines the running frequency when the frequency inverter gives an alarm of fault, which is the percentage relative to highest frequency.

Function code	Function Name	Setting scope	Factory set value
P6.1.14	Action Selection for Momentary Interruption	0: Invalid 1: Deceleration 2: Stop by Deceleration	0
P6.1.15	Judgment Time of Momentary Interruption Voltage Recovery	000.00s~100.00s	000.50
P6.1.16	Voltage Judgment for Momentary Interruption Action	60.0%~100.0% (Standard Bus line voltage)	080.0
P6.1.17	Voltage Judgment for Suspension of Momentary Action	80.0%~100.0% (Standard Bus line voltage)	090.0

When at P6.1.14=0, the frequency inverter continues to run at current frequency in interrupt power-supply or sudden reduction of voltage.

When at P6.1.14=1, in case of interrupt power-supply or sudden reduction of voltage, after the Bus line voltage reduces to corresponding voltage of the set value of P6.1.16 below, the frequency inverter slows down and runs; after the Bus line voltage resets to corresponding voltage of the set value of P6.1.16 above and the duration of time exceeds the time set by P6.1.15, the frequency inverter runs after it is normally accelerated to reference frequency. In the process of deceleration, if the Bus line voltage resets to corresponding voltage of the set value of P6.1.17, the frequency inverter stops slowing down and keeps running at current frequency.

When at P6.1.14=2, in case of interrupt power-supply or sudden reduction of voltage, after the Bus line voltage reduces to below corresponding voltage of the set value of P6.1.16, the frequency inverter slows down and runs; after it slows down to 0Hz and the Bus line voltage hasn't recovered, the frequency inverter stops.

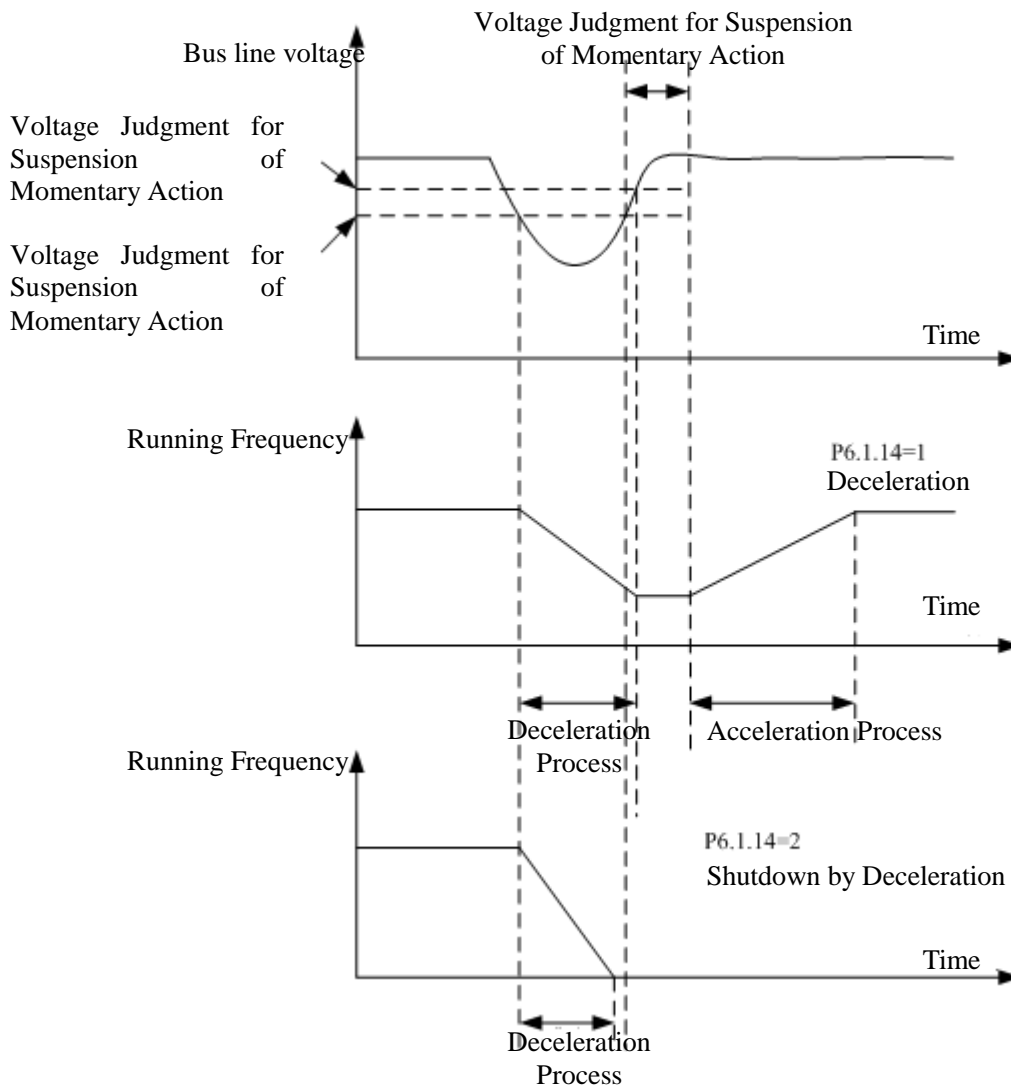

Function code	Function Name	Setting scope	Factory set value
P6.1.18	Off-load Protection Selection	0: Valid 1: Invalid	0
P6.1.19	Off-load Test Level	00.0%~100.0% (Motor Rated Rotating Speed)	010.0
P6.1.20	Off-load Test Time	0.0s~60.0s	01.0

The Function Code P6.1.18 is used to set whether the off-load protection function is valid, 0 and 1 respectively indicates invalid and valid.

If the off-load protection function is valid and the fault handling mode is continuous run or stop by speed reduction, when the output current of the frequency inverter is less than corresponding current value of off-load test level of P6.1.19 and the duration is over off-load test level of P6.1.20, the output frequency of the frequency inverter automatically reduces to 7% of rated frequency, the frequency inverter gives an alarm of A19 in running or decelerating state; in shutdown state, the frequency inverter gives an alarm of Err19, if the load is recovered, the frequency inverter is automatically recovered to run at reference frequency.

Function code	Function Name	Setting scope	Factory set value
P6.1.21	Overspeed Test	0.0%~50.0% (maximum frequency)	20.0
P6.1.22	Overspeed Test Time	0.0s~60.0s	01.0

This function is only valid when the frequency inverter runs with speed sensor vector control. When the frequency inverter detects out actual speed of the motor over reference frequency and the exceeding value is greater than corresponding speed of speed test value P6.1.21 and the duration is over speed test value P6.1.22, the frequency inverter gives an alarm of Fault Err29 and the handling to fault is conducted based on fault protection action mode.

Function code	Function Name	Setting scope	Factory set value
P6.1.23	Speed Deviation greater than Test Value	0.0%~50.0% (maximum frequency)	20.0
P6.1.24	Speed Deviation greater than Test Time	0.0s~60.0s	05.0

This function is only valid when the frequency inverter runs with speed sensor vector control. When the frequency inverter detects out the deviation between actual speed of the motor and reference frequency, if the deviation value is greater than test value P6.1.23 of excessive speed deviation and the duration is longer than test time P6.1.24 of excessive speed deviation, the frequency inverter gives an alarm of Fault Err28 and the handling to fault is conducted based on fault protection action mode. When the test time of excessive speed deviation is 0.0s, this function is invalid.

Function code	Function Name	Setting scope	Factory set value
P6.1.25	Fault Output Terminal Action Selection during Fault Auto Reset Period	0: No Action 1: Action	0

This function code is used to set whether the fault output terminals act during the period of automatic fault reset. When at P6.1.25=0, the fault output terminals cannot act during the period of automatic fault reset. When at P6.1.25=1, the fault output terminals act during the period of automatic fault reset. After automatic fault reset, the fault output terminals also reset.

## 6.8 Group P7 User Function Customization

## P7.0 Basic Group

Function code	Function Name	Setting scope	Factory set value
P7.0.00	User Function 0	U0.0.01	U0.0.01
P7.0.01	User Function 1	U0.0.00~UX.X.XX (exclude P7, P8)	U0.0.02
P7.0.02	User Function 2	U0.0.00~UX.X.XX (exclude P7, P8)	U0.0.03
P7.0.03	User Function 3	U0.0.00~UX.X.XX (exclude P7, P8)	U0.0.07
P7.0.04	User Function 4	U0.0.00~UX.X.XX (exclude P7, P8)	U0.0.08
P7.0.05	User Function 5	U0.0.00~UX.X.XX (exclude P7, P8)	U0.0.17
P7.0.06	User Function 6	U0.0.00~UX.X.XX (exclude P7, P8)	U0.0.18
P7.0.07	User Function 7	U0.0.00~UX.X.XX (exclude P7, P8)	U0.0.00
P7.0.08	User Function 8	U0.0.00~UX.X.XX (exclude P7, P8)	U0.0.00
P7.0.09	User Function 9	U0.0.00~UX.X.XX (exclude P7, P8)	U0.0.00
P7.0.10	User Function 10	U0.0.00~UX.X.XX (exclude P7, P8)	U0.0.00
P7.0.11	User Function 11	U0.0.00~UX.X.XX (exclude P7, P8)	U0.0.00
P7.0.12	User Function 12	U0.0.00~UX.X.XX (exclude P7, P8)	U0.0.00
P7.0.13	User Function 13	U0.0.00~UX.X.XX (exclude P7, P8)	U0.0.00
P7.0.14	User Function 14	U0.0.00~UX.X.XX (exclude P7, P8)	U0.0.00
P7.0.15	User Function 15	U0.0.00~UX.X.XX (exclude P7, P8)	U0.0.00
P7.0.16	User Function 16	U0.0.00~UX.X.XX (exclude P7, P8)	U0.0.00
P7.0.17	User Function 17	U0.0.00~UX.X.XX (exclude P7, P8)	U0.0.00
P7.0.18	User Function 18	U0.0.00~UX.X.XX (exclude P7, P8)	U0.0.00
P7.0.19	User Function 19	U0.0.00~UX.X.XX (exclude P7, P8)	U0.0.00
P7.0.20	User Function 20	U0.0.00~UX.X.XX (exclude P7, P8)	U0.0.00
P7.0.21	User Function 21	U0.0.00~UX.X.XX (exclude P7, P8)	U0.0.00
P7.0.22	User Function 22	U0.0.00~UX.X.XX (exclude P7, P8)	U0.0.00
P7.0.23	User Function 23	U0.0.00~UX.X.XX (exclude P7, P8)	U0.0.00
P7.0.24	User Function 24	U0.0.00~UX.X.XX (exclude P7, P8)	U0.0.00
P7.0.25	User Function 25	U0.0.00~UX.X.XX (exclude P7, P8)	U0.0.00
P7.0.26	User Function 26	U0.0.00~UX.X.XX (exclude P7, P8)	U0.0.00
P7.0.27	User Function 27	U0.0.00~UX.X.XX (exclude P7, P8)	U0.0.00
P7.0.28	User Function 28	U0.0.00~UX.X.XX (exclude P7, P8)	U0.0.00
P7.0.29	User Function 29	U0.0.00~UX.X.XX (exclude P7, P8)	U0.0.00

The function codes of this group are User Customized Parameter Group. The users can summarize the parameters of the function codes (except Group P7 and P8) selected from function codes for display to Group P7.0 as User Customized Parameter for easy operation as view and medication, and the User Customized Parameter Group is not more than 30.

## 6.9 Group P8 Manufacturer Function

## P8.0 Manufacturer Function

Function code	Function Name	Setting scope	Factory set value
P8.0.00	Manufacturer Code	00000~65535	00000

This function code is the manufacturer password entry and displays dedicated function code of the manufacturer, the users don't operate it.

## P8.1 Correction Group

Function code	Function Name	Setting scope	Factory set value
P8.1.00	Voltage Input of Potentiometer Correction Point 1	00.00V~P8.1.02	00.00
P8.1.01	Corresponding reference of Potentiometer Correction Point 1	-100.0%~100.0%	000.0
P8.1.02	Voltage Input of Potentiometer Correction Point 2	P8.1.00~10.00V	10.00
P8.1.03	Corresponding reference of Potentiometer Correction Point 2	-100.0%~100.0%	100.0
P8.1.04	Filtering time of potentiometer	00.00s~10.00s	00.10

The function codes of this group are used to correct the potentiometer to get rid of the impact of zero-offset or voltage attenuation caused by overlong keyboard lines. When leaving the factory, the function parameters of this group have been corrected, when resetting to factory set value, the reset value is the value after factory correction. Generally, the application site is not required to conduct correction.

If adopts potentiometer instead of VF3, the above function codes can be used to correct VF3 as well.

Function code	Function Name	Setting scope	Factory set value
P8.1.05	VF1 actual voltage 1	0.500V~4.000V	2.000
P8.1.06	VF1 indicated voltage 1	0.500V~4.000V	2.000
P8.1.07	VF1 actual voltage 2	6.000V~9.999V	8.000
P8.1.08	VF1 indicated voltage 2	6.000V~9.999V	8.000
P8.1.09	VF2 actual voltage 1	0.500V~4.000V	2.000
P8.1.10	VF2 indicated voltage 1	0.500V~4.000V	2.000
P8.1.11	VF2 actual voltage 2	6.000V~9.999V	8.000
P8.1.12	VF2 indicated voltage 2	6.000V~9.999V	8.000

The function codes of this group are used to correct analog input VF to get rid of the impact of VF input zero-offset or gain. When leaving the factory, the function parameters of this group have been corrected, when resetting to factory set value, the reset value is the value after factory correction. Generally, the application site is not required to conduct correction.

Actual Voltage: use the measuring instruments to measure the voltage between terminal VF and terminal GND, such as multi-meter, etc.

Voltage Display: the voltage display value from the sampling of the frequency inverter refers to voltage (P9.0.19, P9.0.20)display before VF correction of Group P9.

When correcting, input two voltage values on each VF input terminal and then input actually measured voltage value and display voltage to corresponding function codes, the frequency inverter can conduct correction automatically.

Function code	Function Name	Setting scope	Factory set value
P8.1.13	FM1 target voltage 1	0.500V~4.000V	2.000
P8.1.14	FM1 actual voltage 1	0.500V~4.000V	2.000
P8.1.15	FM1 target voltage 2	6.000V~9.999V	8.000
P8.1.16	FM1 actual voltage 2	6.000V~9.999V	8.000
P8.1.17	FM2 target voltage 1 (E102 invalid)	0.500V~4.000V	2.000
P8.1.18	FM2 actual voltage 1 (E102 invalid)	0.500V~4.000V	2.000
P8.1.19	FM2 target voltage 2 (E102 invalid)	6.000V~9.999V	8.000
P8.1.20	FM2 actual voltage 2 (E102 invalid)	6.000V~9.999V	8.000

The function codes of this group are used to correct analog output FM. If the correction has been done when leaving the factory, when resetting to factory set value, the reset value is the value after factory correction. Generally, the application site cannot need to conduct correction.

Actually Measured Voltage: use the measuring instruments to measure the voltage between terminal VF and terminal GND, such as multi-meter, etc.

Target Voltage: refer to theoretical voltage value of the frequency inverter based on corresponding relationship of analog output.

When correcting, output two voltage values on each FM terminal and then input actually measured voltage value and target voltage to corresponding function codes, the frequency inverter can conduct correction automatically.

## 6.10 Group P9 Monitoring Parameter

## P9.0 Basic Monitoring Parameter

P9 Parameter Group is used to monitor running state information of the frequency inverter, the users can set corresponding parameter as required, which can not only be rapidly viewed through panel for easy debugging and maintenance on site, but also read through communication for monitoring of upper computer.

Function code	Function name	Description	Unit
P9.0.00	Running Frequency	Output frequency when the frequency inverter runs	0.01Hz
P9.0.01	Reference frequency	Reference frequency of the frequency inverter	0.01Hz
P9.0.02	Output Current	Output current when the frequency inverter runs	0.01A
P9.0.03	Output Voltage	Output current when the frequency inverter runs	1V
P9.0.04	Bus line voltage	Voltage on DC Bus of the frequency inverter	0.1V
P9.0.05	Output Torque	When the frequency inverter runs, the output torque is the percentage of rated torque of the motor	0.1%
P9.0.06	Output Power	Output frequency when the frequency inverter runs	0.1kW
P9.0.07	Input Terminal Status	Check whether the input terminal has signal input	
P9.0.08	Output Terminal Status	Check whether the output terminal has signal output	
P9.0.09	VF1 Voltage	Check the voltage between VF1 and GND	0.01V
P9.0.10	VF2 Voltage	Check the voltage between VF2 and GND	0.01V
P9.0.11	Custom Display Value	Display coefficient P5.0.15 and the value after conversion of Decimal Point P5.0.16 through customerization	
P9.0.12	Actual Counting Value	View actual counting value of the frequency inverter for counting function	1
P9.0.13	Actual Length Value	View actual counting value of the frequency inverter for fixed-length function	1m
P9.0.14	PID Reference	Product of PID reference value and PID reference feedback quantity	
P9.0.15	PID Feedback	Product of PID feedback value and PID reference feedback rang	
P9.0.16	PULS Impulse frequency	View the frequency of PULSE Impulse Input	0.01kHz
P9.0.17	Feedback Speed	Actual output frequency when the frequency inverter runs	0.1Hz
P9.0.18	PLC Stage	Display which stage the Simple PLC runs at	1
P9.0.19	Voltage before VF1 Correction	Voltage between VF1 and GND before VF1 correction	0.001V
P9.0.20	Voltage before VF2 Correction	Voltage between VF2 and GND before VF2 correction	0.001V
P9.0.21	Line Speed	The sampling line speed of DI6 impulse is equal to the acquisition of impulse count per minute/ per meter	1m/min
P9.0.22	Current Power-on Time	Length of current power-on time	1min
P9.0.23	Current Running Time	Length of current running time	0.1min
P9.0.24	Residual Running Time	Residual running time at Timing Function of P3.1.00	0.1min
P9.0.25	Frequency of Frequency Source A	View the frequency given by Frequency A	0.01Hz

Function code	Function name	Description	Unit
P9.0.26	Frequency of Frequency Source B	View the frequency given by Frequency B	0.01Hz
P9.0.27	Communication Set value	The value set by corresponding communication address A001 is the percentage of the highest frequency	%
P9.0.28	Impulse frequency	View the frequency of PULSE Impulse Input	1Hz
P9.0.29	Encoder Feedback Speed	Actual running frequency of the motor from feedback of the encoder	0.01Hz
P9.0.30	Actual Distance Value	View actual distance value of the distance value of the frequency inverter	
P9.0.31~ P9.0.45	Reservation		
P9.0.46	Operation Result 1	Check the value of operation result 1	
P9.0.47	Operation Result 2	Check the value of operation result 2	
P9.0.48	Operation Result 3	Check the value of operation result 3	
P9.0.49	Operation Result 4	Check the value of operation result 4	
P9.0.50	User Standby Monitoring Value 1	Check the value of user special function	
P9.0.51	User Standby Monitoring Value 2	Check the value of user special function	
P9.0.52	User Standby Monitoring Value 3	Check the value of user special function	
P9.0.53	User Standby Monitoring Value 4	Check the value of user special function	
P9.0.54	User Standby Monitoring Value 5	Check the value of user special function	

**Corresponding Relationship of Input and Output Terminal State**

Whether the vertical line of the digital tube of each digit lights on, it indicates that whether the input and output terminal of each digit has the signal or not. If it lights on, it indicates that corresponding input terminal of this vertical line has signal input or the output terminal has signal output.

The display rules of Function Code P9.0.07 are shown as below:



The display rules of Function Code P9.0.08 are shown as below:

(M is internal Intermediate Delay Relay)

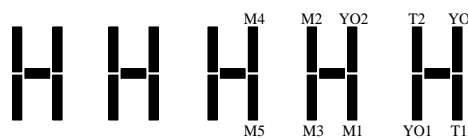

## Chapter 7 Common Function and Application Case

## 7.1 Common Function

## 7.1.1 Start and Stop Control

E Series Frequency inverter has three kinds of start and stop control modes: keyboard control, terminal control and communication control.

**1. Keyboard Control (Set P0.0.03=0)**

Press “RUN” Key on the keyboard, the frequency inverter starts; press “Stop” Key on the keyboard, the frequency inverter stops; the running direction is controlled by Function Code P0.0.06, it is forward rotation when at P0.0.06=0 and it is reverse rotation when at P0.0.06=1.

**2. Terminal Control (Set P0.0.03=1)**

Provide four kinds of terminal start and stop modes for option of the users: two-line mode 1, two-line mode 2, three-line mode 1 and three-line mode 2. Specific use methods are as below:

- Two-line Mode 1 (Set P2.0.11=0)

Any two terminals of DIx and DIy among multifunctional terminals are used to determine forward and reverse running of the more and all are the active level. The terminal function references are as below:

Terminal	Reference Value	Description
DIx	1	Forward Running (FWD)
DIy	2	Reverse Running (REV)

K1	K2	Run Command
0	0	Stop
0	1	REV
1	0	FWD
1	1	Stop

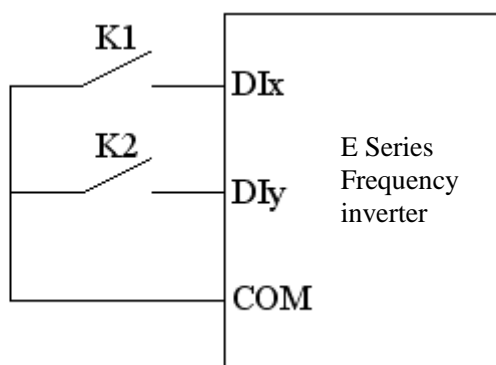

- Two-line Mode 2 (Set P2.0.11=1)

Any two terminals of DIx and DIy among multifunctional terminals are used to determine forward and reverse running of the motor, in which Terminal DIx is used as running enable terminal and DIy is used as terminal of confirming the running direction, all are the active level. The terminal function references are as below:

Terminal	Reference Value	Description
DIx	1	Forward Running (FWD)
DIy	2	Reverse Running (REV)

K1	K2	Run Command
0	0	Stop
0	1	Stop
1	0	REV
1	1	FWD

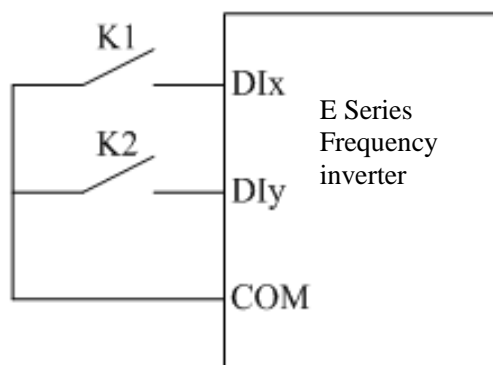

- Three-line Mode 1 (Set P2.0.11=2)

Any three terminals of DIx, DIy and DIIn among multifunctional terminals are used to determine forward and reverse running of the motor, in which Terminal DIx is used as running enable terminal and DIx & DIy are used as terminal of confirming the running direction, DIIn is the active level and DIx & DIy are the active PLS. When the running is needed, the Terminal DIIn must be closed at first and then the PLS of DIx or DIy are used to realize forward or reverse control of the motor. When the shutdown is needed, it is realized through disconnecting the signal of Terminal DIIn. The terminal function references are as below:

Terminal	Reference Value	Description
DIx	1	Forward Running (FWD)
DIy	2	Reverse Running (REV)
DIIn	3	3-line Running Control

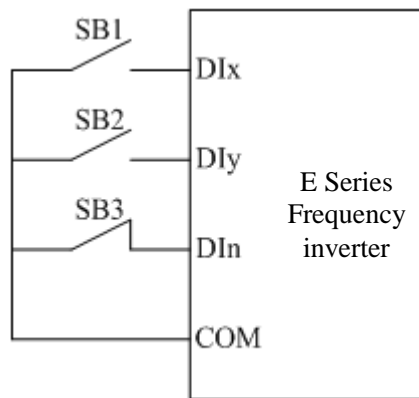

SB1 is the button of normally opened forward running, SB2 is the button of normally opened reverse running and SB3 is the button of normally closed stop.

- 3-line Control Mode 2 (Set P2.0.11=3)

Any three terminals of DIx, DIy and DIIn among multifunctional terminals are used to determine forward and reverse running of the motor, in which Terminal DIIn is used as enable terminal, DIx is used as running terminal and DIy is used as terminal of confirming the running direction, DIIn and DIx are the active level and DIy is the active PLS. When the running is needed, the Terminal DIIn must be closed at first and then the PLS of DIx is used to realize the running of the motor and the state of DIy is used to determine the running direction. When the shutdown is needed, it needs to be realized through disconnecting the signal of Terminal DIIn. The terminal function references are as below:

Terminal	Reference Value	Description
DIx	1	Forward Running (FWD)
DIy	2	Reverse Running (REV)
DIIn	3	3-line Running Control

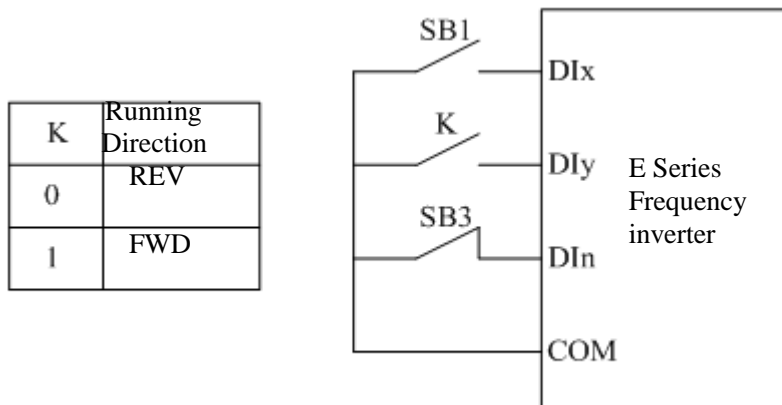

SB1 is the button of normally opened forward running, SB3 is the button of normally closed stop and K is the button of running direction option

### 3. Communication Control (Set P0.0.03=2)

The start, stop, FWD and REV of the frequency inverter is realized by the upper computer through Communication Mode RS-485. E Series Frequency inverter supports Standard MODBUS Protocol, refer to Chapter VIII Communication RS-485 for more details.

#### 7.1.2 Start and Stop Mode

##### 1. Start Mode

E Series Frequency inverter has three kinds of start modes: direct start, speed tracking start and start after brake.

- Direct Start (Set P1.0.10=0)

The frequency inverter starts according to given start frequency (P1.0.12) and start frequency hold time (P1.0.13) and then speeds up to the reference frequency according to the selected acceleration time.

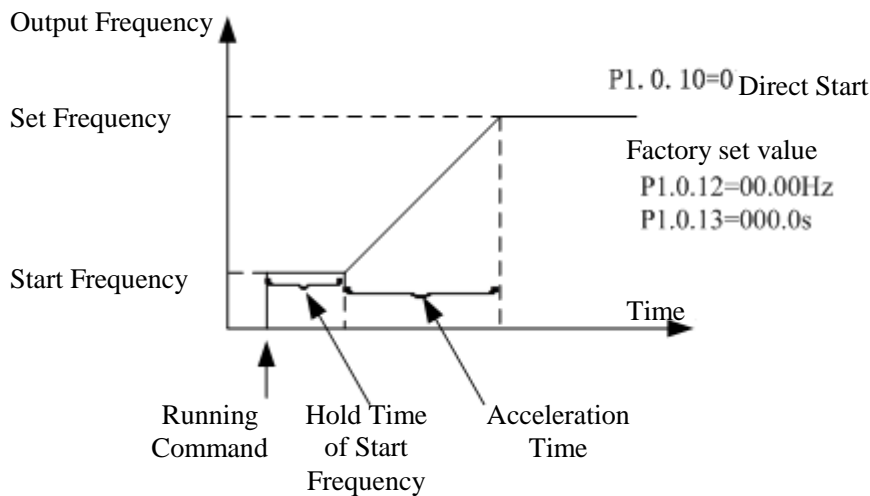

- Speed Tracking Start (Set P1.0.10=1)

The frequency inverter starts the speed tracking according to the speed tracking mode given by speed tracking mode P1.0.11 to track the running speed of the motor at which the frequency inverter starts until being accelerated or decelerated to reference frequency. When the motor hasn't stopped stably or is unable to stop, this function shall be adopted.

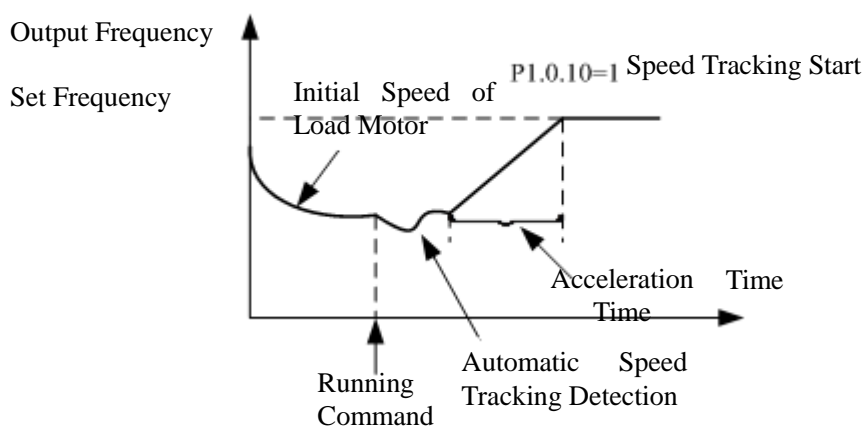

- Speed Tracking Start (Set P1.0.10=2)

Before starting the motor normally, the frequency converter firstly deploys DC braking in accordance with the data set up in the parameters about starting DC braking current (P1.0.14) and starting DC braking time (P1.0.15). If the motor rotates reversely at low speed before starting, this function shall be used when starting the motor by rotating it forward.

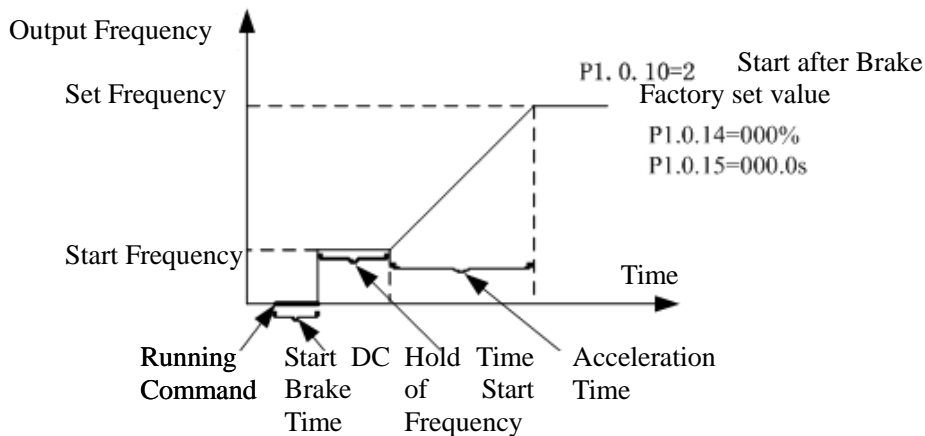

**2. Stop Mode**

E Series Frequency inverter has two kinds of shutdown modes: Deceleration Stop and Free Stop

- Deceleration Stop (Set P1.0.16=0)

After the stop command is effective, the frequency inverter reduces the output frequency according to the selected deceleration time, and it stops when the output frequency is reduced to 0.

When it is required to prevent the frequency inverter from sliding and jittering when it quickly stops or stops at low speed, the stop DC brake function can be used, after the frequency inverter is reduced to frequency given by P1.0.17, it is to wait for the time given by P1.0.18 and start DC brake at current given by P1.0.19 until the time given by P1.0.20 is reached and then the frequency inverter stops DC brake.

When it is required to quickly stop at high speed, the dynamic braking shall be adopted. The built-in brake units of E Series Frequency inverter 15kW and below set the parameters of brake utilization rate P1.0.21 and externally connect brake resistance to adopt dynamic braking; the frequency inverters with power above 15kW can adopt dynamic braking only when they are configured with brake units and brake resistance. Refer to Appendix A2.5 for externally configured brake units and brake resistance.

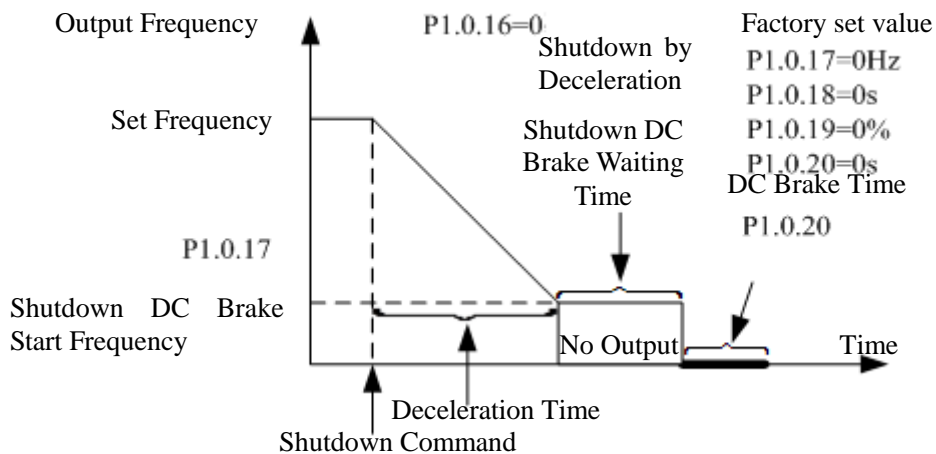

- Free Stop (Set P1.0.16=1)

After the stop command is effective, the frequency inverter immediately terminates the output and the motor stop freely by mechanical inertia. The users haven't had the stop requirements for load or when the load itself has the brake function, the function of free stop can be selected.

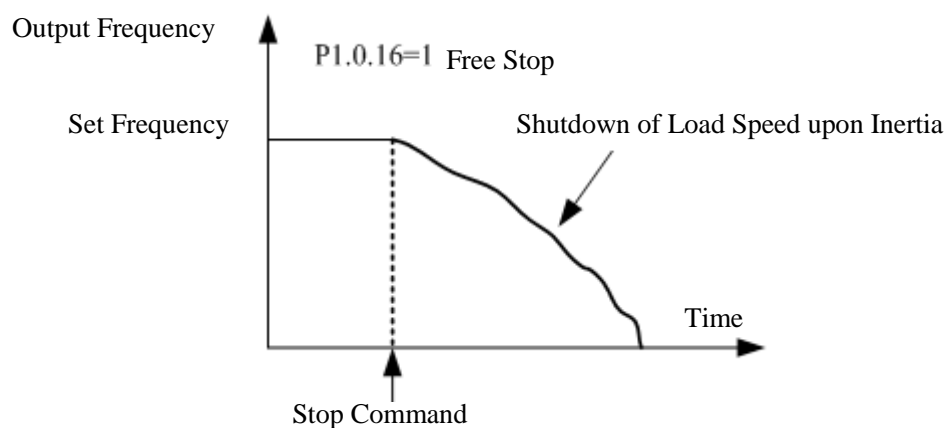

### 7.1.3 Acceleration and Deceleration Mode

Different load characteristics have different requirements for acceleration and deceleration time, E Series Frequency inverter provides three kinds of acceleration and deceleration modes: Straight Line, Curve S 1 and Curve S 2, which are selected through Function Code P0.1.19. Additionally, the acceleration and deceleration time unit can be adjusted and set through Function Code P0.2.03.

- Straight Line (Set P0.1.19=0)

Start the linear speed from start frequency to reference frequency. E Series Frequency inverter provides four kinds of linear acceleration and deceleration modes, which can be switched among different terminal combinations that are selected through acceleration and deceleration time.

- Curve S 1 (Set P0.1.19=1)

The output frequency increases or decrease by Curve S. Curve S is the used for occasions required gentle start or stop. Parameter P0.1.20 and P0.1.21 respectively define the time scale of starting period and ending period of Curve S 1.

- Curve S 2 (Set P0.1.19=2)

In acceleration and deceleration of Curve S, the rated frequency of the motor is always the inflection point of Curve S. Generally, it is used for occasions that the high-speed areas above rated frequency require acceleration and deceleration.

### 7.1.4 Jogging Function

E Series Frequency inverter provides two kinds of the modes to realize jogging function: Keyboard Control and Terminal Control.

- Keyboard Control

Set the function of multi-functional Key JOG as forward jogging or reverse jogging (P5.0.00=1 or 2). The frequency inverter can use Key JOG to realize Jogging Function when it stops, and the jogging running frequency and acceleration and deceleration time can be set through Function Code P0.1.08~P0.1.10.

- Terminal Control

Set the function of multi-functional Dix and DIy as forward jogging or reverse jogging. When the frequency inverter stops, it can use Dix and DIy to realize Jogging Function, and the jogging running frequency and acceleration and deceleration time can be set through Function Code P0.1.08~P0.1.10.

**Note: The jogging function of the above reference modes is the jogging effect when the frequency inverter is at stop state. If the frequency inverter is required to be at running state and the priority is given to the effect of Jogging Function, it is to set Function Code P0.1.25=1.**

### 7.1.5 Running Frequency Control

E Series Frequency inverter provides two Frequency Source Input Channels, that is, Frequency Source A and Frequency Source B respectively, they not only can work independently, but in combination mode through computer. Each frequency source has 14 kinds of references for option, so the optional requirements for different frequencies at different sites can be greatly satisfied. The factory default of the frequency inverter is Frequency Source A Reference. When two frequency sources are combined, Frequency Source A is main channel and Frequency Source B is auxiliary channel by default

Detailed explanation for realization process of frequency selection is shown as the figure below:

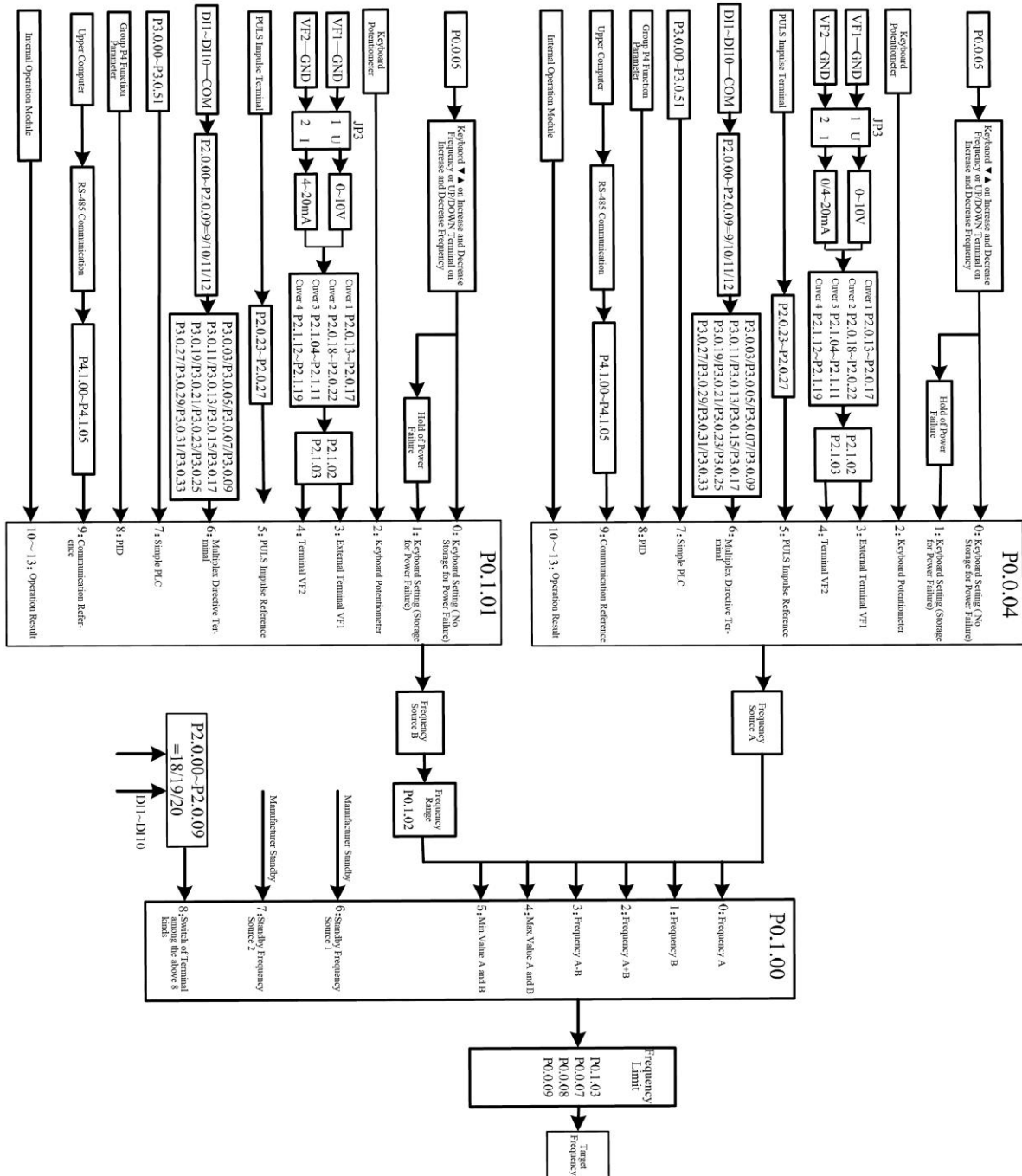

### 7.1.6 Multi-speed Function

E Series Frequency inverter can realize the switch of 16-stage speed at most through different combination state of multiplex directive terminal. As for missing set digit, the calculation is made at state 0.

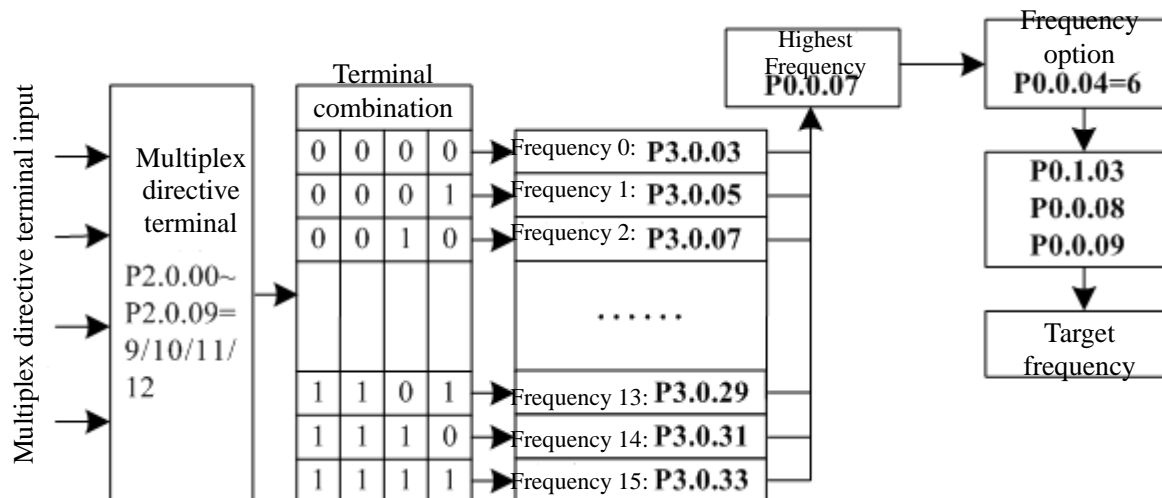

### 7.1.7 Simple PLC

E Series Frequency inverter can automatically run at 16-stage speed at most, the acceleration and deceleration time and the length of running time of each stage can be set independently (refer to Function Code P3.0.03~P3.0.50). Additionally, the times of cycle required can be set through P3.0.00 and P3.0.01.

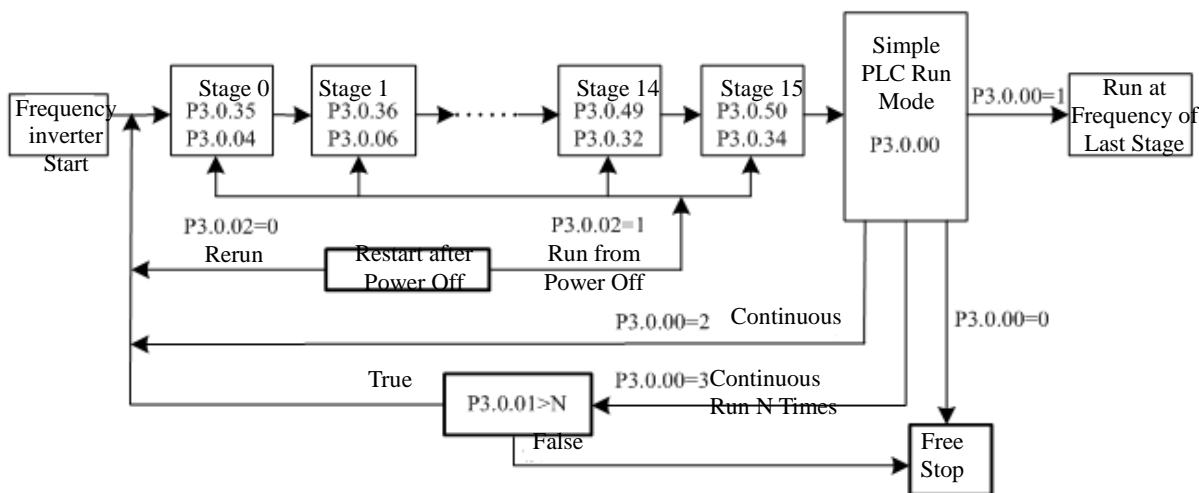

7.1.8 Timing Function

Function Code	Function name	Setting Scope	Factory set value
P3.1.00	Timing Function Selection	0: Invalid 1: Valid	0
P3.1.01	Tinning Running Time Selection	0: Digital Reference (P3.1.02) 1: External Terminal VF1 Reference 2: External Terminal VF2 Reference (Analog input range corresponds to P3.1.02)	0
P3.1.02	Tinning Running Time	0000.0min~6500.0min	0000.0

E Series Frequency inverter has built-in Timing Function to complete its timing running.

Function Code P3.1.00 determines whether the timing function is valid.

Function Code P3.1.01 determines the source of fixed running time.

When at P3.1.01=0, the fixed running time is given by the value set by Function Code P3.1.02.

When at P3.1.01=1 or 2, the fixed running time is given by external analog input terminal. E Series Frequency inverter provides 2-way analog input terminal (VF1, VF2). VF1 and VF2 can input 0V~10V voltage or 0/4mA~20mA current. As for corresponding relation curve between the input of VF1 and VF2 and fixed running time, the users can freely choose from four kinds of the relation curves through function code P2.1.02, in which Curve 1 and Curve 2 are linear relationship able to be set through Function Code P2.0.13~P2.0.22, and Curve 3 and Curve 4 are broken line relationship with two inflection points able to be set through Function Code P2.1.04~P2.1.19. At this time, the analog input range corresponds to the value given by Function Code P3.1.02.

When the Timing Function is effective, the frequency inverter needs to restart timing for every start, when reaching the Reference Time, the frequency inverter stops automatically. During the process of stop, the multi-functional output terminals of the frequency inverter output Signal ON. When the stop process ends, multi-functional output terminals output Signal OFF. Corresponding multi-functional output terminals are Timing Reaches Output (30). When the Reference Time is 0, the fixed time is not limited. Actual time of current running can be viewed through Function Code P9.0.23 (when the frequency inverter shuts down, the display value of P9.0.23 automatically resets to 0).

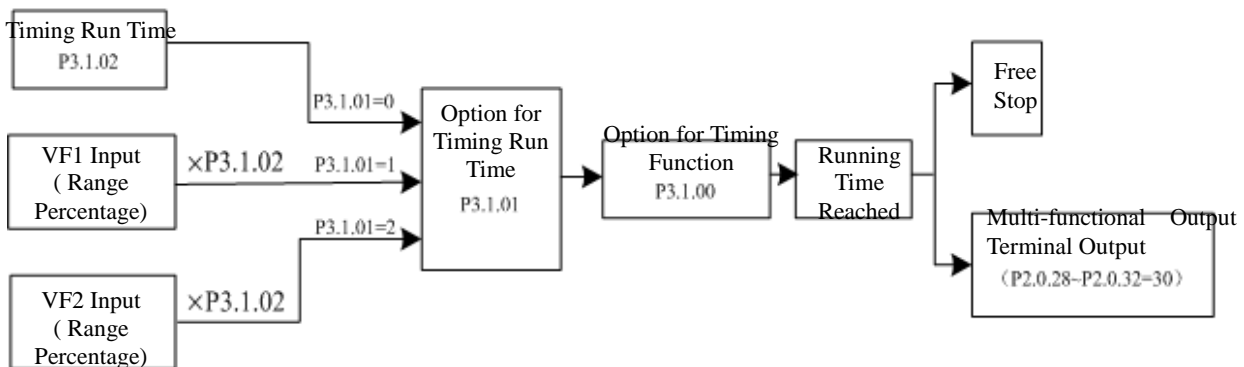

## 7.1.9 Fixed-length Function

Function Code	Function name	Setting Scope	Factory set value
P3.1.08	Reference Length	00000m~65535m	01000
P3.1.09	Actual Length	00000m~65535m	00000
P3.1.10	Impulse Count per meter	0000.1~6553.5	0100.0

E Series Frequency inverter has built-in fixed-length function to realize fixed-length control. In the application, corresponding digital input terminal is required to be set as “Length Counting Input” (Function 30). When the input impulse frequency is higher, Terminal DI16 must be adopted. The formula for length calculation is as below:

$$\text{Actual Length} = \text{Total Impulses from Acquisition of Terminal} / \text{Impulses per meter}$$

When actual length reaches the reference length (value set by P3.1.08), the multi-functional output terminals of the frequency inverter can output Signal ON. Corresponding multi-functional output terminal function is Length Reached (10).

In the process of fixed-length control, the reset operation to actual length can be realized through digital input terminal. Corresponding digital input terminal function is Length Reset (31).

Actual length can be viewed through Function Code P3.1.09 or P9.0.13.

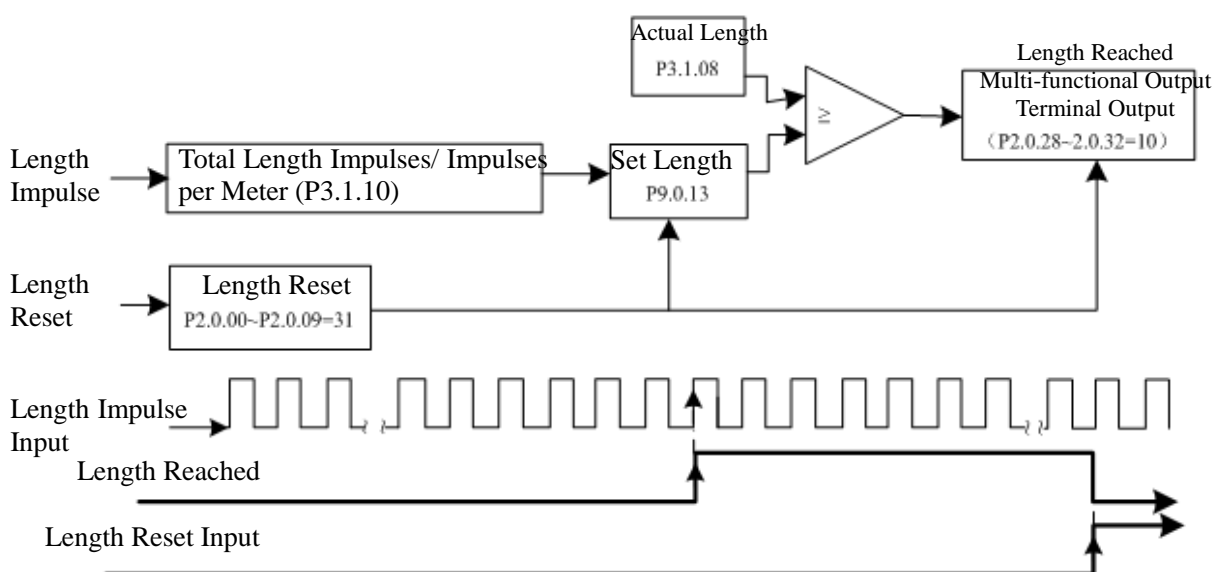

7.1.10 Counting Function

Function Code	Function name	Setting Scope	Factory set value
P3.1.11	Reference Count Value	00001~65535	01000
P3.1.12	Designated Count Value	00001~65535	01000

The counting function of E Series Frequency inverter has two-level signal output, that is, reference counting Value Reached and designated counting Value Reached. In the application, corresponding digital input terminal function is required to be set as “Counter Input” (Function 28). When the impulse frequency is higher, Terminal DI6 must be adopted.

When actual counting value reaches the reference value (set by P3.1.11), the multi-functional output terminals of the frequency inverter can output Signal ON. Corresponding multi-functional output terminal function is Reference Counting Value Reached (8).

When actual counting value reaches the reference value (set by P3.1.12), the multi-functional output terminals of the frequency inverter can output Signal ON. Corresponding multi-functional output terminal function is Designated Counting Value Reached (9).

In the counting process, the reset operation to actual counting value can be realized through digital input terminal. Corresponding digital input terminal function is Counter Reset (29)

Actual counting value can be viewed through Function Code P9.0.12.

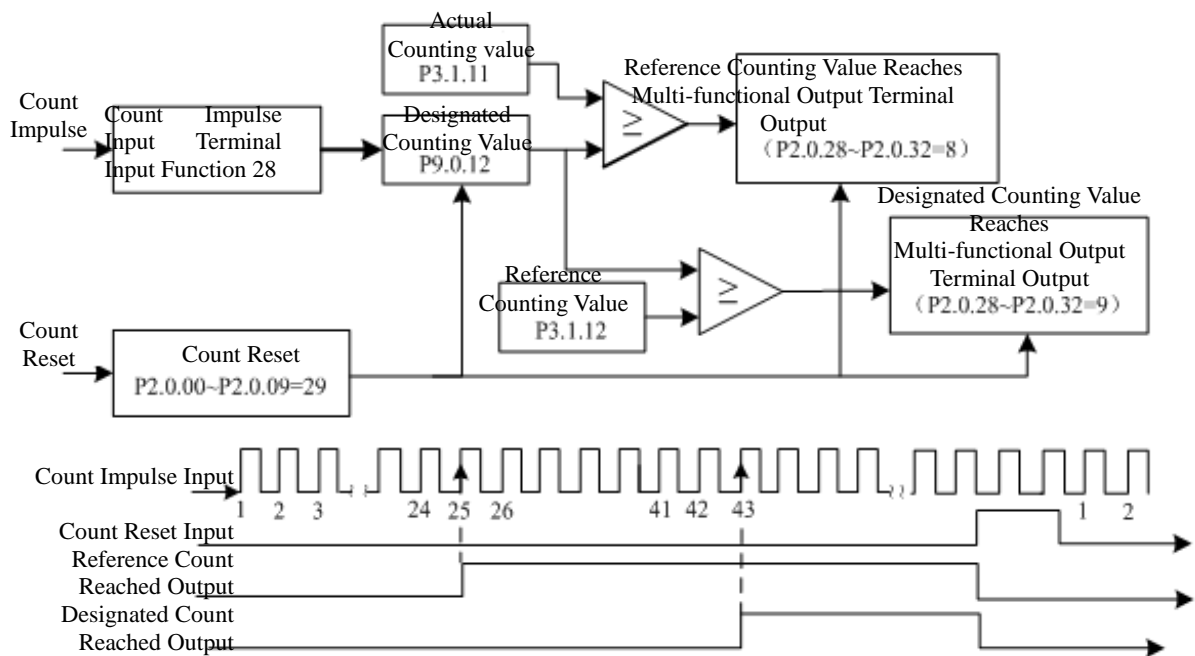

## 7.1.11 Distance Control Function

Function Code	Function name	Setting Scope	Factory set value
P3.1.13	Distance Set value 1	-3200.0~3200.0	0000.0
P3.1.14	Distance Set value 2	-3200.0~3200.0	0000.0
P3.1.15	Impulse Count per Distance	000.00~600.00	000.00

E Series Frequency inverter has built-in Distance Control Function. In the application, corresponding digital input terminal function is required to be set as “Encoder A Input” (Function 52) and “Encoder B Input” (Function 53). Terminal DI5 and DI6 of CDI-E100 Series can connect high-speed impulse of the encoder, the impulse frequency of the encoder of other terminals is not allowed more than 200Hz. The impulse frequency of CDI-E102 Series encoder is not allowed more than 200Hz. The impulse frequency of CDI-E180 Series encoder is not allowed more than 200Hz. In case of exceeding 200Hz, the open-collector encoder expansion card is required to be configured (set P0.1.26=10). The phase sequence of the encoder determines the plus-minus of actual distance.

$$\text{Actual Distance} = \pm \text{Total Impulses from Acquisition of Terminal} / \text{Impulses per distance}$$

For the digital tube has five digits, when the distance is less than -999.9, all displayed decimal points of the digital tube completely indicate minus value, e.g. “1.0.1.0.0” means -1010.0.

When actual distance reaches the set value 1 (value set by P3.1.13), the multi-functional output terminals of the frequency inverter can output Signal ON. Corresponding multi-functional output terminal function is the Distance Set Value 1 Reached (56).

When actual distance reaches the set value 2 (value set by P3.1.14), the multi-functional output terminals of the frequency inverter can output Signal ON. Corresponding multi-functional output terminal function is the Distance Set Value 2 Reached (57).

In the process of distance control, the reset operation to actual distance can be realized through digital input terminal. Corresponding digital input terminal function is the Distance Reset (54).

Actual distance can be viewed through Function Code P9.0.30.

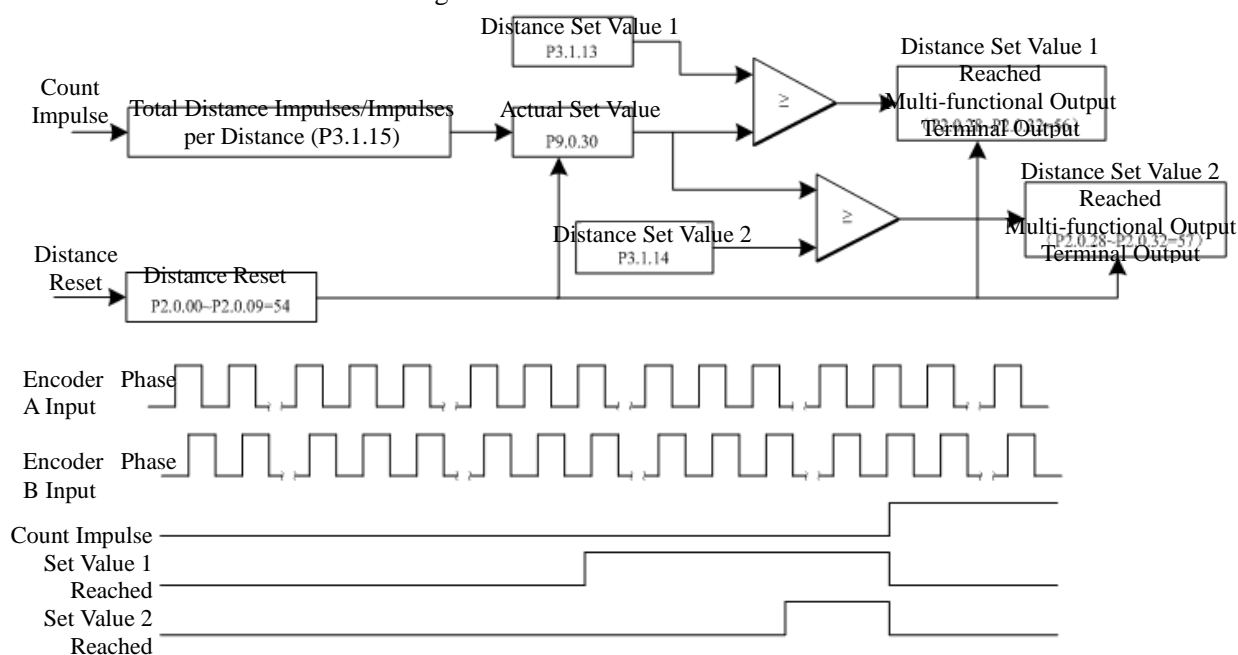

### 7.1.12 Simple Internal Relay Programmable Function

E Series Frequency inverter has five built-in virtual Intermediate Delay Relays, which not only can collect the physical signals of digital input terminal of the frequency inverter, but virtual signals of multi-functional output terminals (00~59). And then it is to conduct simple logic running and output the results to multi-functional output terminals or equivalent digital input terminal.

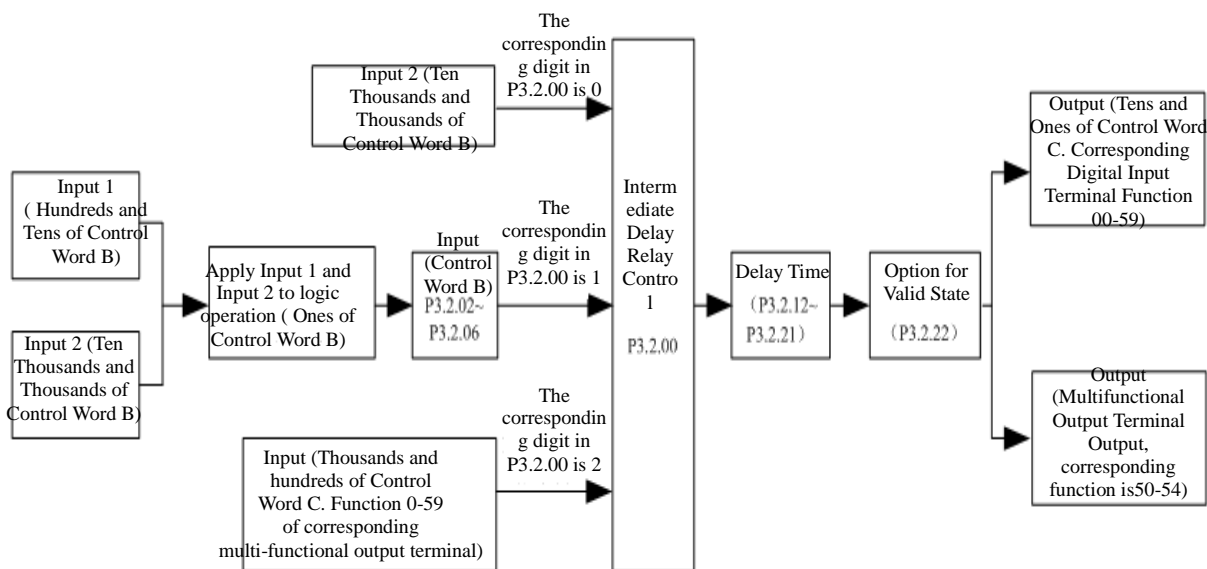

Description for Control Logic Function of Intermediate Delay Relay Control Word B

Function code	Set value for unit's digit	Function	Description
P3.2.02 P3.2.03 P3.2.04 P3.2.05 P3.2.06	0	Input 1	If input 1 is true, the logic result is true, If input 1 is false, the logic result is false
	1	Input 1 and NOT	If input 1 is true, the logic result is false If input 1 is false, the logic result is true
	2	Input 1 and Input 2 AND	If Input 1 and Input 2 are true, the logic result is true or false
	3	Input 1 and Input 2 OR	Any one of Input 1 and Input 2 is true, the logic result is true,
	4	Input 1 and Input 2 XOR	If Input 1 and Input 2 are opposite logic, the logic result is true If Input 1 and Input 2 have same logic, the logic result is false
	5	The valid reference of Input 1 is valid The valid Reference of Input 2 is invalid	If input 1 is true, the logic result is true, If input 2 is true and input 1 is false, the logic result is true, the logic result is false

Function code	Set value for unit's digit	Function	Description
P3.2.02 P3.2.03 P3.2.04 P3.2.05 P3.2.06	6	Valid reference of Input 1 Rise Edge is valid Valid reference of Input 2 Rise Edge is invalid	If Input 1 Rising Edge is true, the logic result is true If Input 2 Rising Edge is true, the logic result is false
	7	Reverse valid signal of Input 1 Rising Edge	If Input 1 Rising Edge is true, the logic result is reverse
	8	Input 1 Rise Edge is valid and output a impulse signal with width of 200ms	If Input 1 Rising Edge is true, the logic result is true, after keeping it 200ms, the logic result becomes false
	9	Input 1 Rise Edge and Input 2 AND	If Input 1 Rising Edge and Input 2 Rising Edge are true, the logic result is true or false

E.g. in case of setting Function Code P3.2.00 (Intermediate Delay Relay Control)=00112, we can learn from referring to the explanation of Function Code P3.2.00 that Relay 5 (M5) & Relay 4 (M4) are determined by Control Word A and Relay 3 (M3) & Relay 2 (M2) are determined by Control Word B, and Relay 1 (M1) is determined by thousands and hundreds of Control Word C, as shown in the figure below:

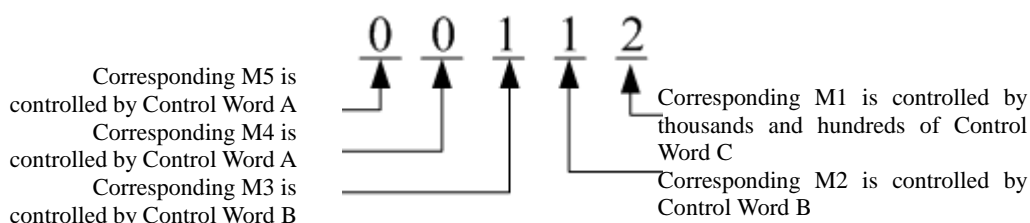

In combination with the example above, in case of setting P3.2.01 (Intermediate Delay Relay Control Word A)=10111, it is to compulsively set M5=1 and M4=0. For M3, M2 and M1 are not determined by Control Word A, so the setting of P3.2.01 to M3, M2 and M1 is invalid.

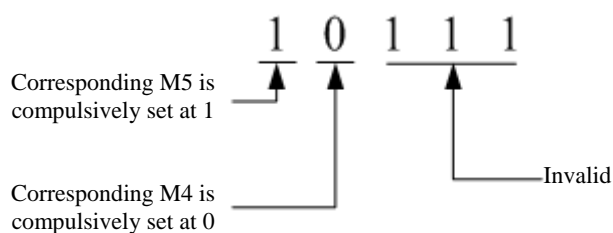

In combination with the example above, in case of setting P3.2.03 (Control Word B of Corresponding M2)=01022, we can learn from referring to the explanation of Function Code P3.2.03 that M2=DI2&&DI3, as shown in the figure below:

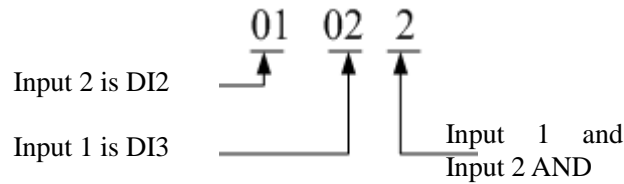

Equivalent as shown in the figure below:

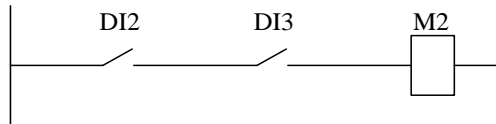

In combination with the example above, in case of setting the tens and ones of P3.2.08 (Control Word C of Corresponding M2) at 01 (input terminal function of corresponding digital), it indicates that the function of M2 is forward running. If 51(Synchronous Intermediate Relay M2) is set among P2.0.28~P2.0.32 at the same time, corresponding multi-functional output terminal outputs the signal.

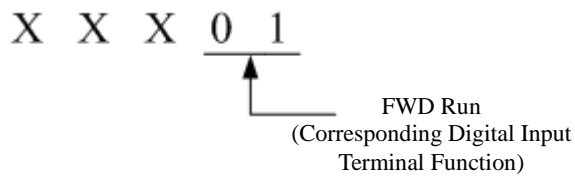

The Intermediate Relay can not only respectively preset the delay time for its connection and disconnection through Function Code P3.2.12~P3.2.16 and P3.2.17~P3.2.21, but preset whether the reverse operation is conducted for output signals through Function Code P3.2.22. In combination with the example above, in case of setting P3.2.13 (delay time of corresponding M2 connection)=10.0s and P3.2.18 (delay time of corresponding M2 disconnection)=5.0s, when DI2 and DI3 are connected, M2 is not immediately connected, but connected after waiting for 10.0s. Similarly, when one of DI2 or DI3 is disconnected, M2 is not immediately disconnected, but disconnected after waiting for 5.0s.

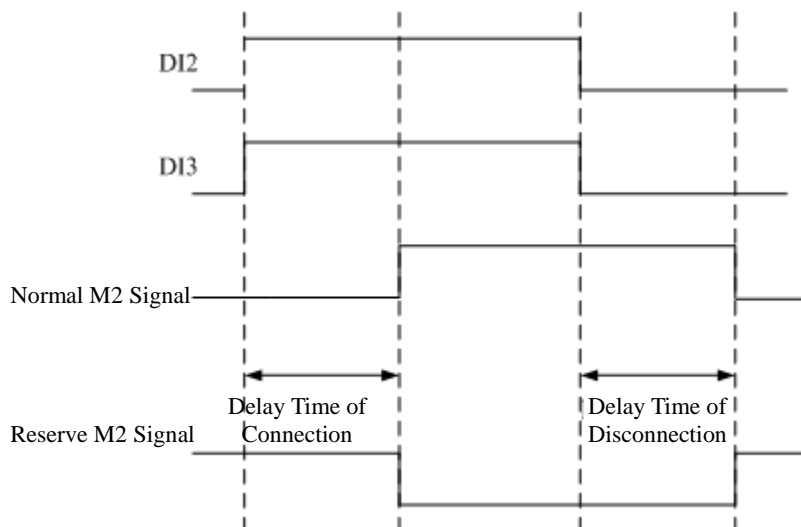

## 7.1.13 Internal Timer Function

E Series Frequency inverter has two built-in timers, their start, shutdown timing and timer reset can be realized through digital input terminal. The fixed Time Reached can output the signals through multi-functional output terminal.

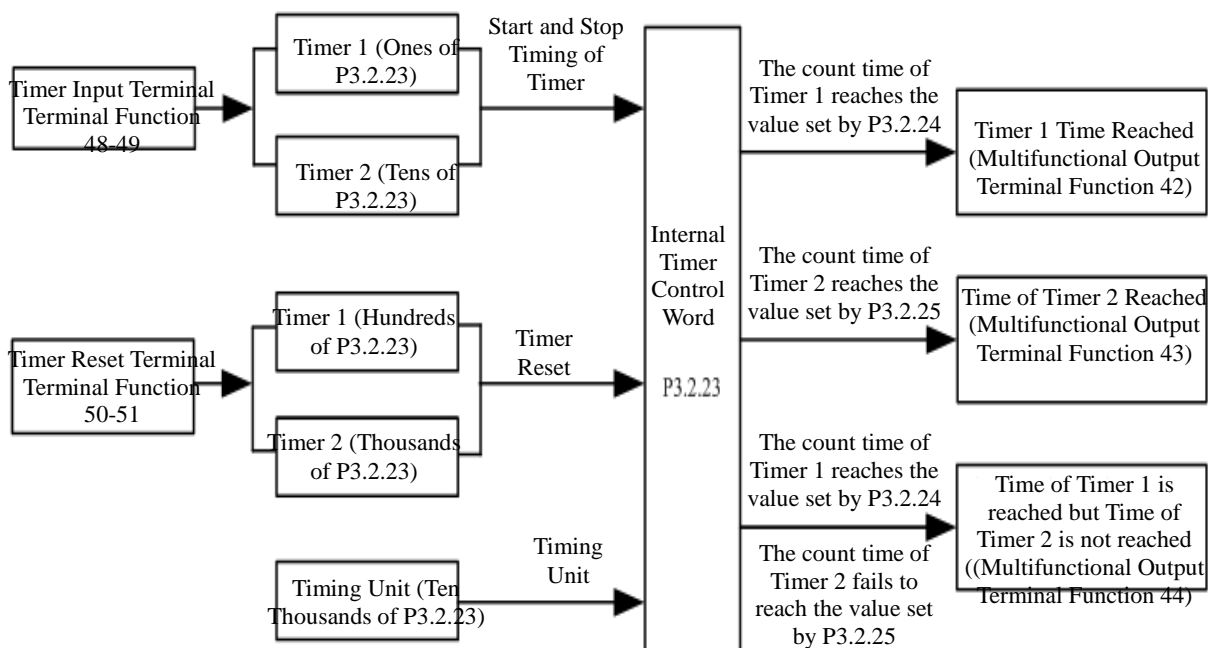

When the signal of the output terminal of the timer (terminal function 48~49) is valid, the timer starts timing. When the signal of the input terminal of the timer is invalid, the timer stops timing and keeps current value.

When actual timing value of Timer 1 reaches the value set by P3.2.24, the multi-functional output terminals of the frequency inverter can output Signal ON. Corresponding multi-functional output terminal function is the Time of Timer 1 Reached (42).

When actual timing value of Timer 2 reaches the value set by P3.2.25, the multi-functional output terminals of the frequency inverter can output Signal ON. Corresponding multi-functional output terminal function is the Time of Timer 2 Reached (43).

When actual timing value of Timer 1 reaches the value set by P3.2.24, but actual timing value of Timer 2 fails to reach the value set by P3.2.25, the multi-functional output terminals of the frequency inverter output Signal ON. When actual timing value of Timer 2 reaches the value set by P3.2.25, the multi-functional output terminals of the frequency inverter output Signal OFF. Corresponding multi-functional output terminal function is Time of Timer 1 is reached, but Time of Timer 2 is not reached (44).

In the process of timing, the reset operation to actual timing value can be realized through digital input terminal. Corresponding digital input terminal function is the Timer Reset Terminal (50~51).

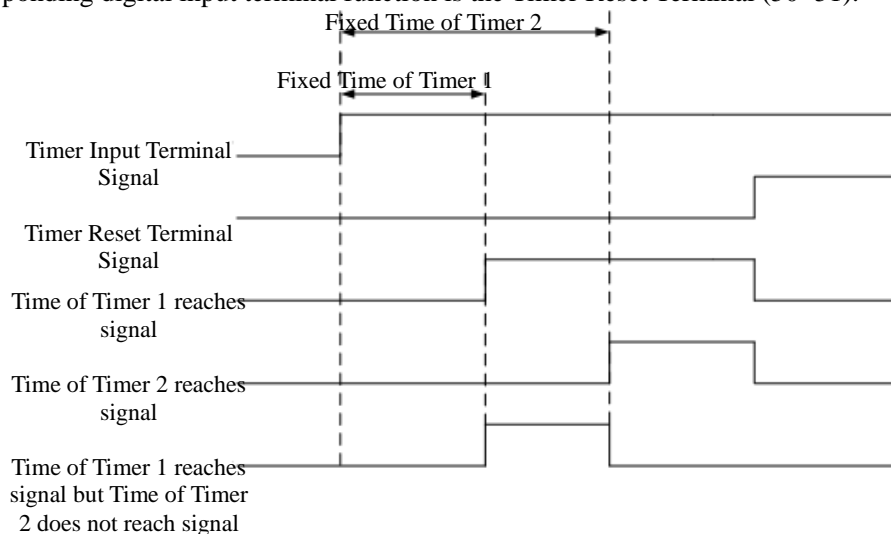

7.1.14 Internal Operation Module Function

E Series Frequency inverter has four built-in operation modules, which collect the data of two function codes of the frequency inverter (remove the value after the decimal point) to conduct simple operation and finally output the operation results into special use occasions. Certainly, the operation results can also be used to realize the actions of multi-functional output terminals and the output of the analog signal.

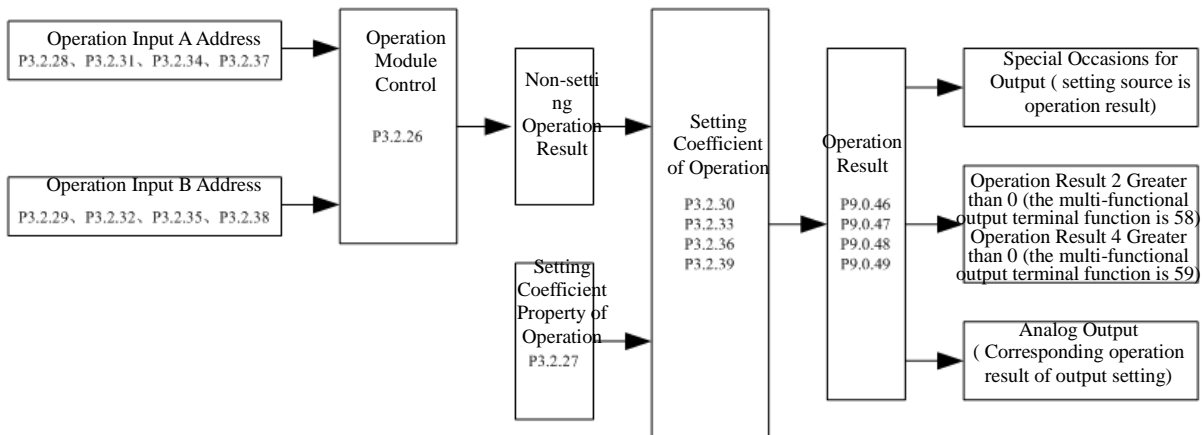

Control Explanation for Operation Module

Function code	Corresponding set value	Function	Description
P3.2.26	0	No Operation	No operation conducted
	1	Add Operation	Address A data + Address B data
	2	Subtraction Operation	Address A data - Address B data
	3	Multiply Operation	Address A data × Address B data
	4	Division Operation	Address A data ÷ Address B data
	5	Greater than Judgment	If Address A data > Address B data, the non-setting operation result is 1, or it is 0.
	6	Equal to Judgment	If Address A data = Address B data, the non-setting operation result is 1, or it is 0.
	7	Equal to or Greater than Judgment	If Address A data ≥ Address B data, the non-setting operation result is 1, or it is 0.
	8	Integration	Time of every Address B Data (ms as unit) means Address A Data added to non-setting operation result, e.g. If Address A Data is 100 and Address B Data is 1000, it indicates that 10 is added to non-setting operation result per 1000ms. The scope of the operation results is -32767~32767. When the operation results is less than -9999, all displayed decimal points of the digital tube completely indicate minus value, e.g. “1.0.1.0.0” means -10100.
9~F	Reservation	Reservation	

## Explanation for Setting Coefficient Property of Operation

Function code	Corresponding set value	Function	Description
P3.2.27	0	Conduct setting at no decimal fraction to system by multiplication algorithm	Non-setting Operation Result $\times$ Setting Coefficient of Operation
	1	Operate the Setting Coefficient by multiplication with one decimal	Non-setting Operation Result $\times$ Setting Coefficient of Operation $\div 10$
	2	Operate the Setting Coefficient by multiplication with two decimals	Non-setting Operation Result $\times$ Setting Coefficient of Operation $\div 100$
	3	Operate the Setting Coefficient by multiplication with three decimals	Non-setting Operation Result $\times$ Setting Coefficient of Operation $\div 1000$
	4	Operate the Setting Coefficient by multiplication with four decimals	Non-setting Operation Result $\times$ Setting Coefficient of Operation $\div 10000$
	5	Operate the Setting Coefficient by division without decimal	Non-setting Operation Result $\div$ Setting Coefficient of Operation
	6	Operate the Setting Coefficient by division with one decimal	Non-setting Operation Result $\div$ Setting Coefficient of Operation $\times 10$
	7	Operate the Setting Coefficient by division with two decimals	Non-setting Operation Result $\div$ Setting Coefficient of Operation $\times 100$
	8	Operate the Setting Coefficient by division with three decimals	Non-setting Operation Result $\div$ Setting Coefficient of Operation $\times 1000$
	9	Operate the Setting Coefficient by division with four decimals	Non-setting Operation Result $\div$ Setting Coefficient of Operation $\times 10000$
	A	Operate the Setting Coefficient by division without decimal	Non-setting operation result $\div$ number of function code corresponding to operation setting coefficient
	B	Operate the Setting Coefficient by division with one decimal	Non-setting operation result $\div$ number of function code corresponding to operation setting coefficient $\times 10$
	C	Operate the Setting Coefficient by division with two decimals	Non-setting operation result $\div$ number of function code corresponding to operation setting coefficient $\times 100$
	D	Operate the Setting Coefficient by division with three decimals	Non-setting operation result $\div$ number of function code corresponding to operation setting coefficient $\times 1000$
	E	Operate the Setting Coefficient by division with four decimals	Non-setting operation result $\div$ number of function code corresponding to operation setting coefficient $\times 10000$

**Note: 5~9 are operation setting coefficients and can be directly included in the operation, and A~E are not operation setting coefficients and can't be directly included in the operation. The operation setting coefficient is used to point to a function code number and only the number of function code can be included in the operation.**

## Control Explanation for Operation Results

Operation Results oriented	Scope of Operation Results
Operation Results Oriented Reference Frequency	-Highest Frequency~Highest Frequency (Remove Decimal Point)
Operation Results Oriented Reference Upper Frequency	0~Highest Frequency (Remove Decimal Point)
Operation Results Oriented PID Reference	-1000~1000 means -100.0%~100.0%
Operation Results Oriented PID Feedback	-1000~1000 means -100.0%~100.0%
Operation Results Oriented Torque Reference	-1000~1000 means -100.0%~100.0%
Operation Results Oriented Analog Output	Operation Result 1: -1000~1000
	Operation Result 2: 0~1000
	Operation Result 3: -1000~1000
	Operation Result 4: 0~1000

The operation result 1 can be reviewed through Function Code P9.0.46.

The operation result 2 can be reviewed through Function Code P9.0.47.

The operation result 3 can be reviewed through Function Code P9.0.48.

The operation result 4 can be reviewed through Function Code P9.0.49.

e.g. the sum of VF1 Reference and VF2 Reference can be used to torque reference through operation. When the scope of torque reference is 0.0%~100.0%,the desired scope of operation results is 0~1000. For the scope of reference voltage of VF1 and VF2 is 00.00~10.00m, the scope of the non-setting operation results of Operation 2 is 0~2000, but the desired scope of operation results can be reached through division by two. The parameters of the function code are required to be set as below:

Function code	Function name	Set value	Explanation
P1.1.14	Torque Reference Source	9	Torque Reference Source from Operation Result 2
P3.2.26	Operation Module	H.0010	Select addition operation for operation 2
P3.2.27	Operation Setting Coefficient Property	H.0050	Operate the setting coefficient by division without decimals
P3.2.31	Input A of Operation 2	09009	Operate corresponding Function Code P9.0.09 by unsigned number
P3.2.32	Input B of Operation 2	09010	Operate corresponding Function Code P9.0.10 by unsigned number
P3.2.33	Setting Coefficient of Operation 2	2	The setting coefficient is 2

The above description means:

$$\text{Operation result} = (\text{number in P9.0.09} + \text{number in P9.0.10}) \div 2$$

If P3.2.27= H.00A0, the above description means:

$$\text{Operation result} = (\text{number in P9.0.09} + \text{number in P9.0.10}) \div \text{number in P0.0.02}$$

If P0.0.02=1,

$$\text{Operation result} = (\text{number in P9.0.09} + \text{number in P9.0.10}) \div 1$$

### 7.1.15 PID FUNCTION

E Series Frequency inverter has built-in PID Regulator, which is configured with the option for signal reference channel and signal feedback channel, the users can easily realize automatic regulation of process control and control applications on constant voltage, constant flow, constant temperature, tension, etc. When in use of PID Frequency Closed-loop Control, the users need to preset the running frequency and reference mode and select P0.04 as 8 (PID Control), that is, PID Automatic Regulation on Output Frequency, related parameters of PID are given in Group P4 and the use methods of PID are as below:

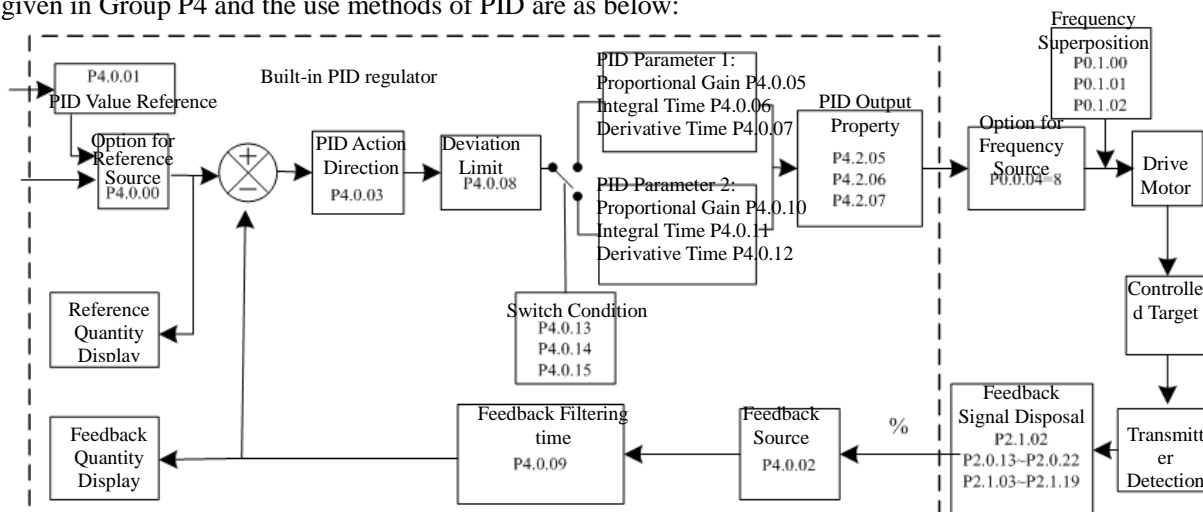

The frequency inverter has 2 built-in equivalent PID computing units, the performance parameters can be preset separately to realize optimum usage of regulating speed and accuracy, the users can use multi-functional terminals or setting deviation adjustment to freely switch different regulation performance required by different stage.

### 7.1.16 Wobbling Function

Function code	Function name	Setting scope	Factory set value
P3.1.03	Wobbling Reference Mode	0: Relative to Reference frequency 1: Relative to Highest Frequency	0
P3.1.04	Wobbling Range	000.0%~100.0%	000.0
P3.1.05	Kicking Range	00.0%~50.0%	00.0
P3.1.06	Wobbling Cycle	0000.1s~3000.0s	0010.0
P3.1.07	Rise Time of Wobbling Triangular Wave	000.1%~100.0%	050.0

In some occasions, the Wobbling can improve the control performance of the equipments, e.g. winding equipments in textile, fiber, etc., the use of the Wobbling Function can improve the uniform tightness of the winding of spindle. Through setting Function Code P3.1.03~P3.1.07, it is to realize the reference frequency as wobbling performance of the central frequency.

The Function Code P3.1.03 is used to confirm the reference quantity of amplitude. The Function Code P3.1.04 is used to determine the size of the amplitude. The Function Code P3.1.05 is used to confirm the size of mutation frequency of the wobbling.

When at P3.1.03=0, the amplitude is variable amplitude system in relative to reference frequency, which will change along the reference frequency

$$\text{Amplitude} = \text{Reference Frequency} \times \text{Amplitude of Wobbling}$$

$$\text{Mutation Frequency} = \text{Reference Frequency} \times \text{Amplitude of Wobbling} \times \text{Sudden Jump of Amplitude}$$

When at P3.1.03=1, the amplitude is fixed amplitude system in relative to reference frequency, which is a fixed amplitude.

$$\text{Amplitude} = \text{Reference Frequency} \times \text{Amplitude of Wobbling}$$

$$\text{Mutation Frequency} = \text{Reference Frequency} \times \text{Amplitude of Wobbling} \times \text{Sudden Jump of Amplitude}$$

Wobbling Cycle: refer to the time value of a complete wobbling cycle.

Triangular Wave Rise Time of Wobbling: refer to the percentage of Triangular Wave Rise Time relative to

wobblating cycle (P3.1.06) .

Triangular Wave Rise Time = Wobblating Cycle × Triangular Wave Rise Time of Wobblating, Unit: Second.

Triangular Wave Fall Time = Wobblating Cycle × (1 - Triangular Wave Rise Time of Wobblating), Unit: Second.

Refer to the figure below for explanation:

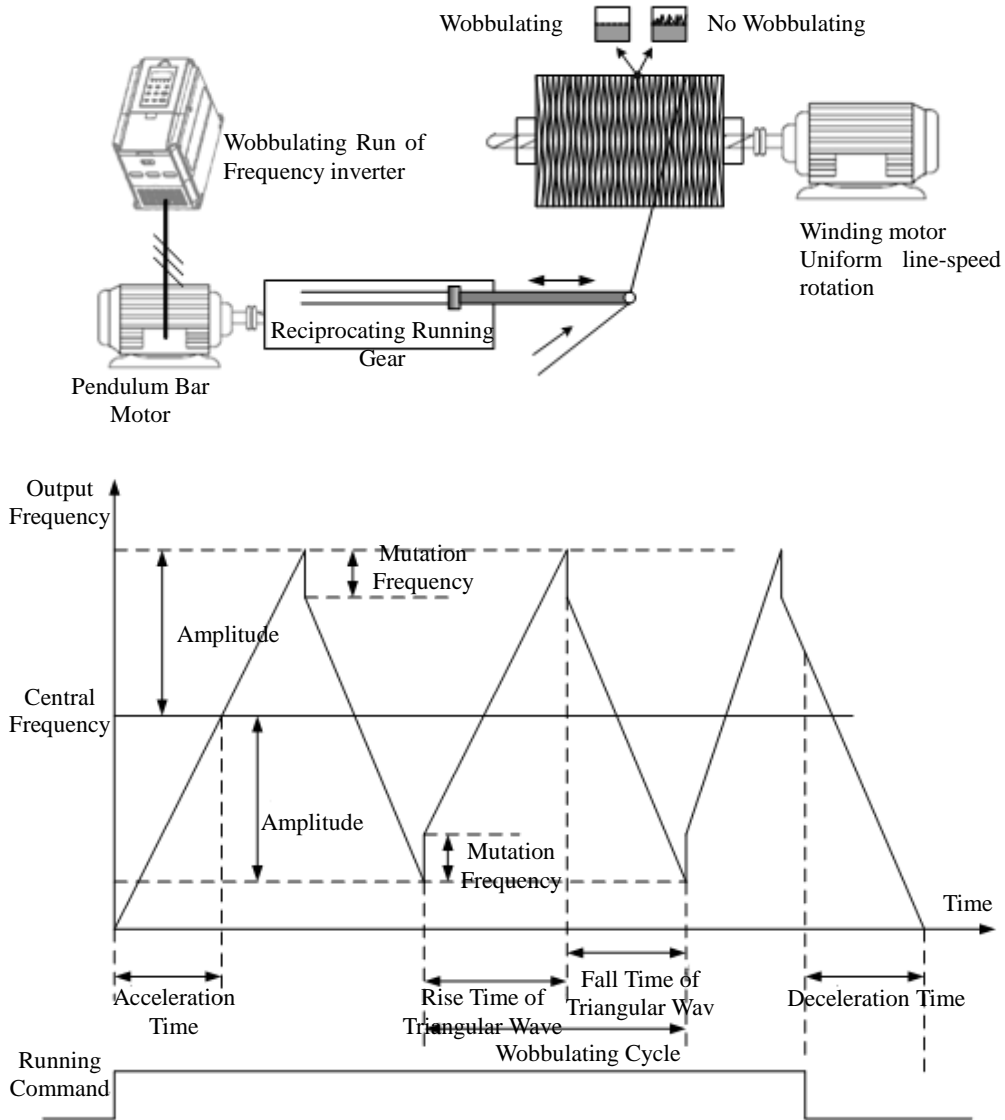

Note: the output frequency of wobblating is subject to upper frequency and lower frequency

7.1.17 Analog Input/Output Use

1. Analog Input

E Series Frequency inverter support 2-way analog input, which can be voltage signal or can also be current signal.

Input	VF1	Voltage source	Shift switch J5-1 to U side, which enable to receive the signal at 0V~10V DC.
		Current source	Shift switch J5-1 to I side, which enable to receive the signal at 0/4mA~20mA.
	VF2	Voltage source	Shift switch J5-2 to U side, which enable to receive the signal at 0V~10V DC.
		Current source	Shift switch J5-2 to I side, which enable to receive the signal at 0/4mA~20mA.

When the frequency inverter uses the analog input as frequency source reference, torque reference, PID reference or feedback, corresponding curve can be chosen for the relationship between the voltage or current value and reference value or feedback quantity through function code P2.1.02, and the corresponding curve parameters are set. The sampling value of Terminal VF can be viewed through Function Code P9.0.09 and P9.0.10. Refer to the figure below for explanation:

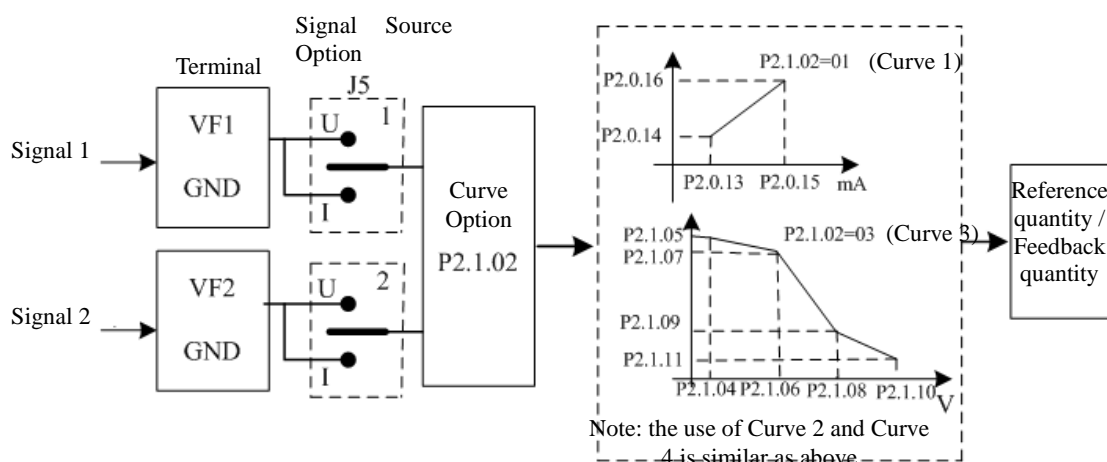

NOTE: The default value of inverter's analog input is 0V~10V. If the input is 0mA~20mA, it will remain 0V~10V; if the input is 4mA~20mA, it will remain 2V~10V.

2. Analog Output

E Series Frequency inverter support 2-way analog output, which can be voltage signal or can also be current signal.

Output	FM1	Voltage source	Shift switch J6 to U side, which enable to receive the signal at 0V~10V DC.
		Current source	Shift switch J6 to I side, which enable to receive the signal at 0mA~20mA.
	FM2	Voltage source	Shift switch J7 to U side, which enable to receive the signal at 0V~10V DC.
		Current source	Shift switch J7 to I side, which enable to receive the signal at 0mA~20mA.

FM1 and FM2 can indicate internal running parameters through output analog mode. The indicated contents of the parameters can be selected through Function Code P2.0.33 and P2.0.34. The analog output signal can be corrected through Function Code P2.0.36 and P2.0.37 before output, the correction effect is shown in the figure below:

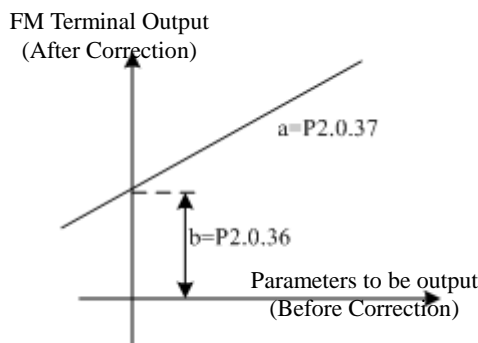

Corrected Output  $Y = aX + b$  (X means running parameters to be output, a means output gain and b is output offset).

### 7.1.18 Digital Input/Output Use

#### 1. Digital Input

CDI-E100 Series Frequency inverter has 6 digital input terminals with No. DI1~DI6, in which DI6 is high speed input terminal. CDI-E102 Series Frequency inverter has 5 digital input terminals with No. DI2~DI6, in which DI6 is high speed input terminal. CDI-E180 Series Frequency inverter is configured with 6 digital input terminals with No. DI1~DI6, in which DI6 is high speed input terminal. Besides, it can externally connect IO Expansion Card and additional 4 IO Expansion Cards with No. DI7~DI10 can be adopted. VF1 and VF2 can also be set as digital input through Function Code P2.1.23 and P2.1.24.

The digital input terminal adopts internal power by factory default, which is valid for short circuit to Terminal COM (indicated as 1) and invalid for disconnection (indicated as 0), it also can make its indicated effect reverse through setting Function Code P2.1.00 and P2.1.01. When VF is used as digital input, the short circuit of 10V Power Terminal of the frequency inverter and VF is valid, but invalid for disconnection, and the indicated effect can also be reversed through Function Code P2.1.25.

Terminal DI1~DI3 can also be used to set the delay effect time through Function Code P2.1.26~P2.1.28 and available for the occasions that require to delay the signal effect.

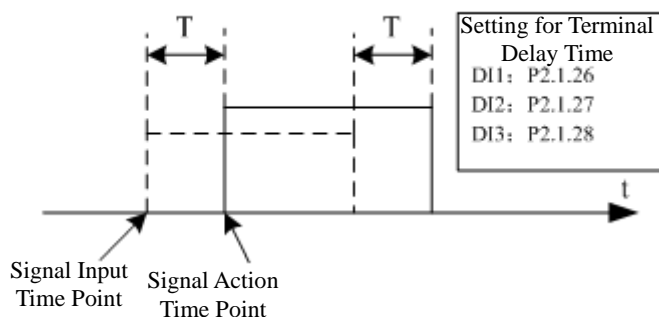

T is the delayed time

#### 2. Digital Output

CDI-E100 Series Frequency inverter has three multi-functional output terminals, that is, YO, T1 and T2. E102 Series inverter has only one multi-function output terminal, i.e. T1. CDI-E180 Series Frequency inverter is configured with three multi-functional output terminals, that is, YO, T1 and T2. Besides, it can externally connect IO Expansion Card and then additional two IO Expansion Cards can be adopted, that is, YO1 and YO2.

Name of Terminal	Function Code	Configuration	Description for Output
YO1	P2.0.28	E180 Expansion Card	Transistor; drive capability: 48VDC, 50mA below
T1 Relay	P2.0.29	E Series Control Panel	Relay: drive capability: 250VAC, 3A below or 30VDC, 1A below
T2 Relay	P2.0.30	E Series Control Panel (E102 invalid)	Relay: drive capability: 250VAC, 3A below or 30VDC, 1A below
YO2	P2.0.31	E180 Expansion Card	Transistor; drive capability: 48VDC, 50mA below
FMP(YO/FMP) (P2.1.20=0)	P2.0.35 P2.1.21	E Series Control Panel (E102 invalid)	Transistor; able to output high-frequency impulse 0.01kHz~100kHz; drive capability: 24VDC, 50mA below
YO(YO/FMP) (P2.1.20=1)	P2.0.32	E Series Control Panel (E102 invalid)	Transistor; drive capability: 48VDC, 50mA below

Output Terminal YO, T1 and T2 can also be used to set the delay effect time through Function Code P2.1.29~P2.1.31 and available for the occasions that require to delay the signal effect.

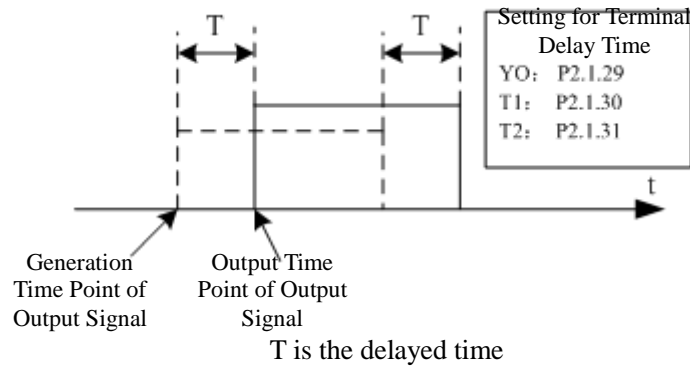

### 7.1.19 Communication of Upper Computer

As the automation control is more widely used, the applications on controlling the running of the frequency inverter the upper computer through communication mode have been too much, so the use of Network RS485 can conduct communication with E Series Frequency inverter of Delixi. CDI-E100 Series Frequency inverter has communication interface terminal on control panel, that is, SG+ and SG-, so the communication can be realized by connecting the communication line and programming on upper computer. While E180 Series Frequency inverter hasn't had communication interface terminal on control panel, so the communication can be realized by externally connecting the expansion card and programming on upper computer.

E Series Frequency inverter adopts MODBUS-RTU Protocol, which can only be used as slave station, namely, it can only handle and reply the data from upper computer, but not initiatively send the data. When communicating, it is required to set the parameters of Function Code P4.1.00~P4.1.05. These parameters need to be set based on actual conditions, if the setting is improper, it may cause the communication unable to be done or abnormal communication. When the communication timeout (P4.1.04) is set at non-zero data, the frequency inverter automatically shuts down after the fault of communication timeout to avoid the frequency inverter from running without control to lead to adverse consequence when the communication or upper computer breaks down. As for specific use of Communication Protocol, refer to the Description of Chapter VIII for more details. The figures below are communication diagram of E100, E102 and E180.

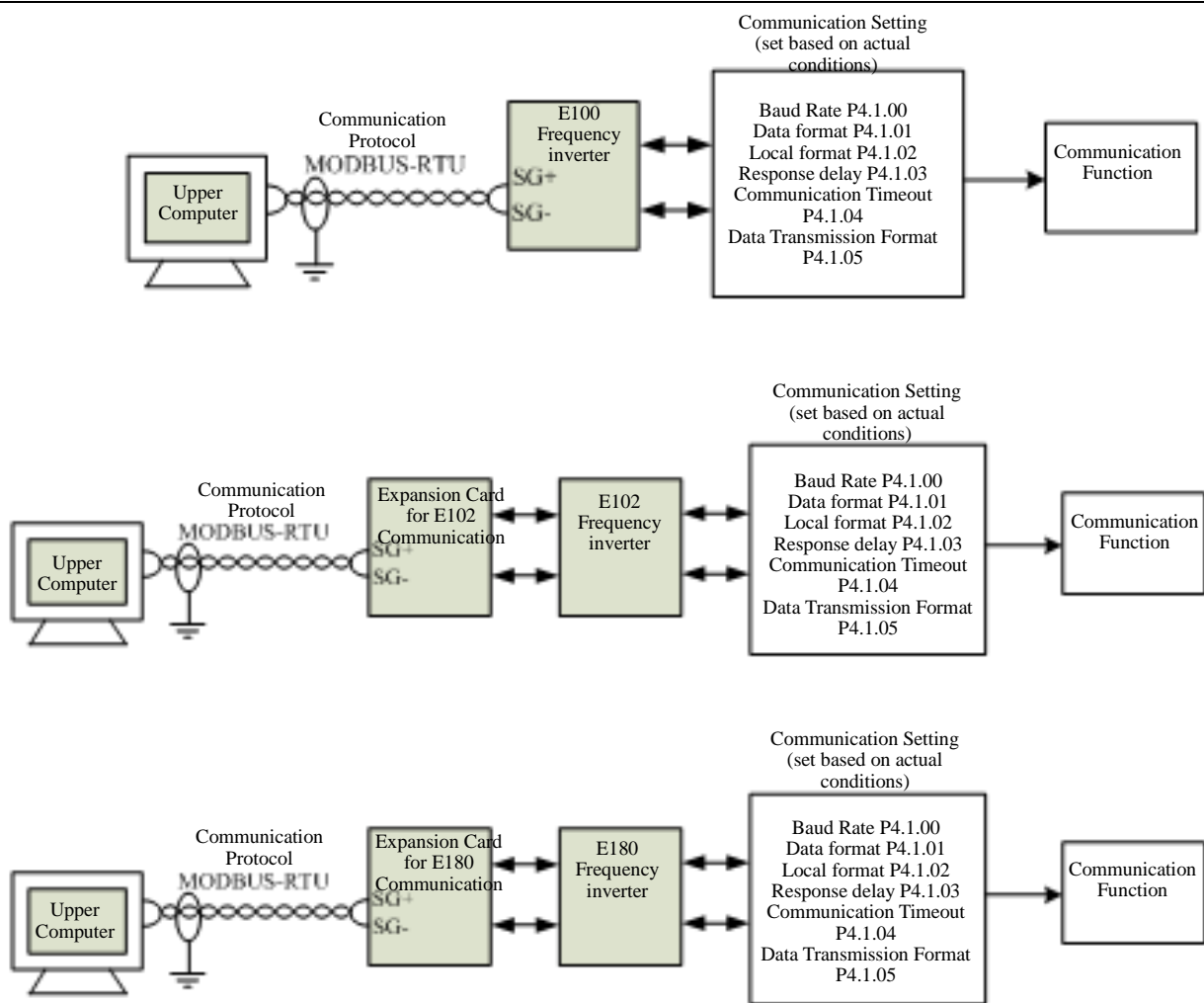

7.1.20 Parameter Identification

When the control mode of the frequency inverter is vector control mode (P0.0.02=1 or 2), the accuracy for the parameters of motor of P0.0.19~P0.0.23 directly effects the control performance of the frequency inverter, if the frequency inverter has good control performance and running efficiency, the frequency inverter must acquire the accurate parameters of the controlled motor. If exact parameters of motor have been acquired, the parameters of motor can be manually input into P0.0.19~P0.0.23, or the Parameter Identification Control Function is required to be used.

The Parameter Identification Control Modes include Static Identification, Complete Identification, Load Synchronous Machine Identification and Non-load Synchronous Machine Identification. As for Parameter Identification Control of the asynchronous motor, it suggests using the Complete Identification Mode at on-load run. (P0.0.24=2

Parameter Identification Control Mode	Applicable Occasions	Identification Effect
Static Identification	Only applicable for occasions not convenient to separate the motor and rotating system from asynchronous motor	Worse
Complete Identification	Only applicable for occasions able to completely separate the motor and rotating system from asynchronous motor	Best
Load Synchronous Machine Identification	Only applicable for occasions not convenient to separate the motor and rotating system from synchronous motor	Not bad
Non-load Synchronous Machine Identification	Only applicable for occasions able to completely separate the motor and rotating system from synchronous motor	Best

As for the occasions hard to separate the asynchronous motor and rotating system, the motor with same brand and type can be used, after complete identification, the parameters for properties of the motor are copied to corresponding parameter of P0.0.19~P0.0.23.

Function code	Function name	Setting scope	Factory set value
P0.0.24	Parameter Identification Control	00: No action 01: Static identification 02: Complete identification 11: Synchronous machine on-load identification (Invalid E100) 12: Synchronous machine non-load identification (Invalid E100)	00

CDI-E100, E102 Series only supports Static Identification and Complete Identification, but not Load Synchronous Machine Identification and Non-load Synchronous Machine Identification. While E180 Series supports all modes.

0: No Action

When the frequency inverter is under normal operating state, the parameter identification is not required to be done.

1: Static Identification

When the load cannot completely separate from the asynchronous motor, this mode can be adopted. Before conducting the identification, the parameter value of P0.0.13~P0.0.18 must be set correctly. After completing the setting and pressing Key RUN, the frequency inverter operates the static identification, the completion of the identification only can acquire three parameter values of P0.0.19~P0.0.21.

2: Complete Identification

When the load completely separates from the asynchronous motor, this mode can be adopted (if the conditions allow, please try to adopt this mode, for it has better effect). Before conducting the identification, the parameter value of P0.0.13~P0.0.18 must be set correctly. After completing the setting and pressing Key RUN, the frequency inverter operates the complete identification, the completion of the identification only can acquire five parameter values of P0.0.19~P0.0.23.

11: Load Synchronous Machine Identification

When the load cannot completely separate from the synchronous motor, this mode can be adopted. Before conducting the identification, the parameter value of P0.0.13~P0.0.18, P0.1.26, P0.1.27 and P0.1.34 must be set correctly. After completing the setting and pressing Key RUN, the frequency inverter operates the Load Synchronous Machine Identification, the completion of the identification can acquire initial position angle of the synchronous, and the initial position angle is the necessary conditions for normal operation of the synchronous motor, so the first use of the synchronous motor must conduct identification.

12: Non-load Synchronous Machine Identification

When the load completely separates from the synchronous motor, this mode can be adopted (if the conditions allow, please try to adopt this mode, for it has better effect), such a mode can acquire accurate parameters of the motor so as to achieve better running performance of the synchronous motor. Before conducting the identification, the parameter value of P0.0.13~P0.0.18, P0.1.26, P0.1.27 and P0.1.34 must be set correctly.

#### Steps for Motor Parameter Identification:

1. If the motor can completely separate from the load, please confirm its state and the motor cannot influence other related devices when the motor is rotating.
2. After power-on, please confirm that the Parameter P0.0.13~P0.0.18 of the frequency inverter is the same with corresponding parameter on the nameplate of the motor.
3. Please confirm that when the running control mode of the frequency inverter is at P0.0.03=0, the panel control is adopted (i.e. only Key RUN on the control panel can identify the running signal).
4. Set Function Code P0.0.24 and select the mode of parameter identification. If the Complete Identification is selected, the Function Code is at P0.0.24=2, press Key “ENTER” and then press Key “RUN”, the keyboard displays “FE5F”, the indicator of “RUN” lights on and the indicator of “TUNE” keeps flashing. The parameter identification continues running about 30s~60s, when the display of “FE5F” disappears, the indicator of “TUNE” lights off, such a condition means the end of parameter identification, the frequency inverter can automatically store the identified the characteristic parameters of the motor into corresponding function code.

When CDI-E180 Series Frequency inverter drives the synchronous motor, the feedback signal of the encoder is required, before identification, the parameters of the encoder must be set correctly. In the process of identifying the synchronous motor, the rotating action is required, the best identification mode is no-load dynamic identification, if the conditions don't allow, and the load dynamic identification can be conducted.

7.2 Application Cases

7.2.1 Switching function of dual-pump

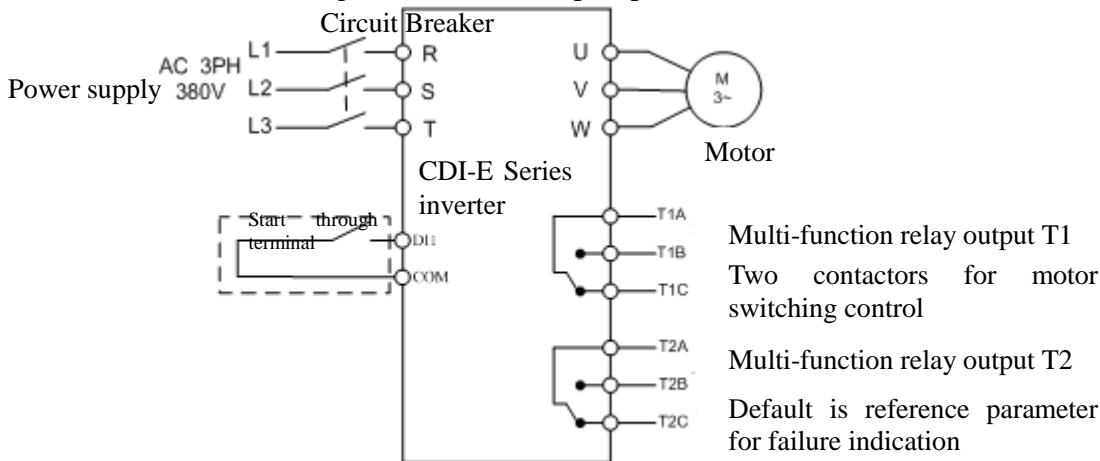

General parameters of dual-pump function (when you debug dual-pump function, please input 100 for function code P5.0.19)

Function code	Name	Set value	Description
P0.0.03	Option for Running Control Mode	0	Start via Run key on Control Panel (default)
		1	Start via External Terminal DI1 (P2.0.00=01)
P3.0.00	Simple PLC Running mode	0	End of Single Running and Stop
		1	End of Single Running and Save Final Value
		2	Continuous Running (default)
		3	N cycles
P3.0.01	Cycle number(s), N	0	Switching times of dual-pump cycle when at P3.0.00=3
P3.0.02	Option of PLC Power-off Memory	11	Memory for shutdown and power-off
P3.2.13	Pump Switching Time Point	22.0s	The set value is larger than actual deceleration time of the inverter
P3.2.17	Restart Time Point	24.0s	The set value is larger than the set value of P3.2.13
P3.0.04	Pump 1 Running time	0	Operation time of pump #1
P3.0.06	Pump 2 Running time	0	Operation time of pump #2
P3.0.35	Frequency resource of pump #1	H.010	Determined by keyboard potentiometer (default)
		H.020	Determined by keyboard frequency
		H.030	VF1 input
		H.040	VF2 input
P3.0.36	Frequency resource of pump #2	H.010	Determined by keyboard potentiometer (default)
		H.020	Determined by keyboard frequency
		H.030	VF1 input
		H.040	VF2 input
P3.0.51	Pump Running time Unit	0	Second
		1	Hour
		2	Minute
P5.0.19	Factory set values Recovery	00	No Operation
		30	Users Current Parameter Backup
		60	User Backup Parameters Recovery
		100	Factory set values of dual-pump function recovery

Factory set values (used for internal function test and no modification is allowed)

Function code	Set value	Function code	Set value
P0.0.04	7	P3.2.03	00100
P2.0.29	52	P3.2.04	00117
P3.2.00	112	P3.2.07	3914

7.2.2 PID control for Water Supply at Permanent Pressure

1. Diagram of wiring connection

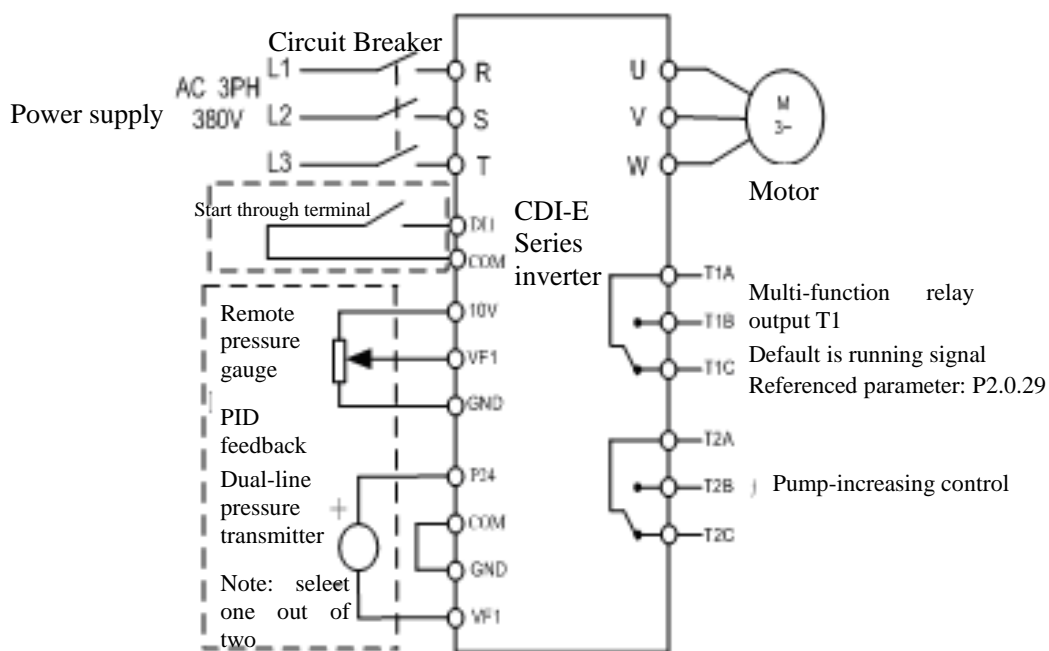

Note: if it is the remote pressure gauge, put J5-1 (VF1 DIP switch) to U side, and if it is the pressure transmitter, put J5-1 to I side.

2. Control Diagram of one-driving-two pump-increasing

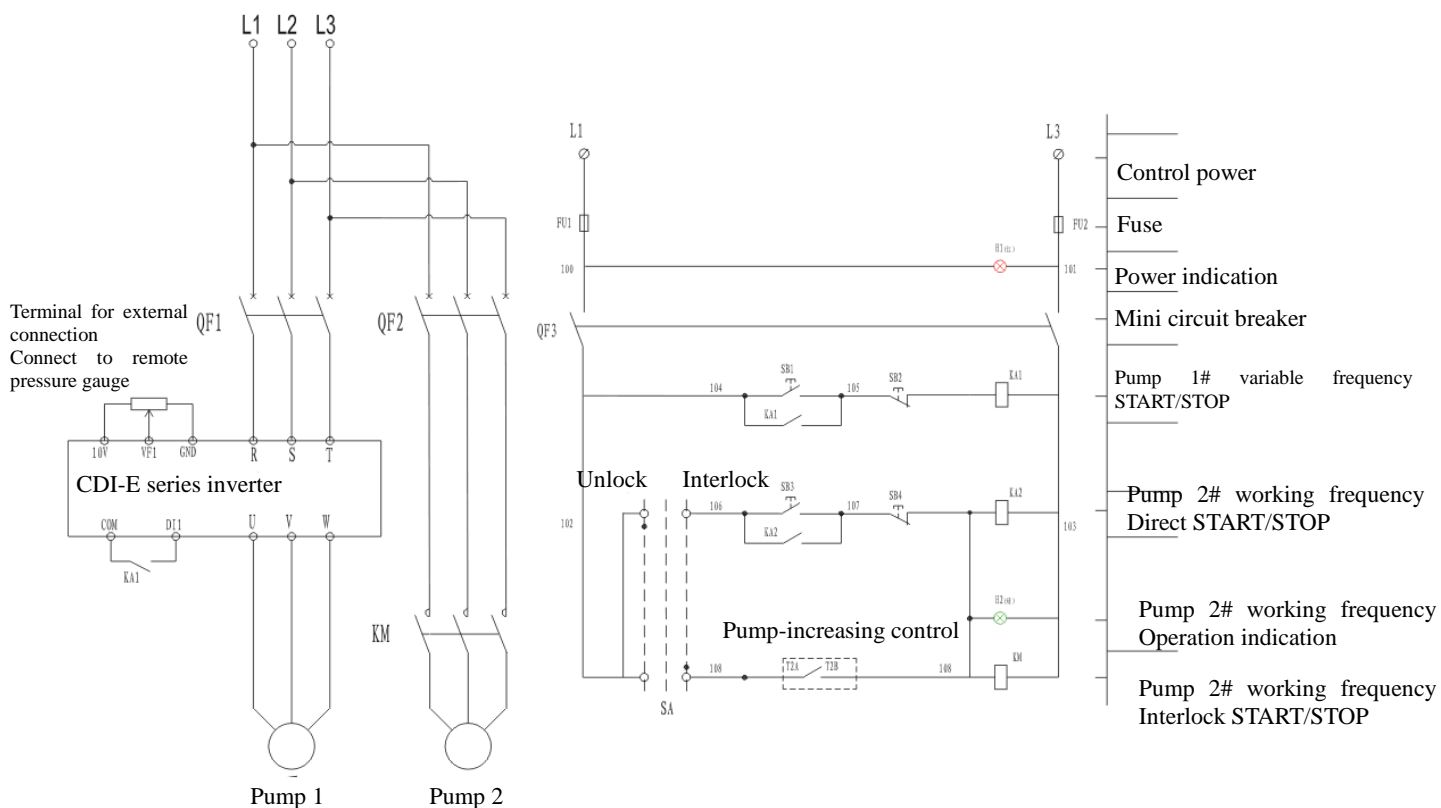

**General parameters of permanent water supply (when user debugs the function of permanent water supply, please input 101 to function code P5.0.19)**

Function code	Function name	Set value	Description
P0.0.03	Option for Running Control Mode	0	Start Key Run on Control Panel (default)
		1	Start the External Terminal DI1 (P2.0.00=01)
P0.0.09	Lower frequency	10.00	Set based on actual conditions
P0.0.11	Acceleration Time	Machine type	Set based on actual conditions
P0.0.12	Deceleration Time	Machine type	Set based on actual conditions
P4.0.00	PID Reference Source	0	The reference source is given from P4.0.01
P4.0.01	PID Value Reference	50.0%	The reference value is given by the users based on actual needs, which is the percentage relative to P4.0.04.
P4.0.02	PID Feedback Source	0	The feedback source inputs from Terminal VF1
P4.0.03	PID Action Direction	0	PID Direct Action. The bigger feedback is, the smaller the frequency is. (default)
		1	PID Reverse Action. The smaller the feedback is, the smaller the frequency is.
P4.0.04	PID Given Feedback Range	1000	Set based on actual feedback range (1000 means 1MPa)
P3.2.24	PID Sleep Threshold Value	90.0%	The reference value is given by the users based on actual needs, which is the percentage relative to P4.0.04.
P3.2.25	PID Wake-up Threshold Value	10.0%	The reference value is given by the users based on actual needs, which is the percentage relative to P4.0.04.
P3.2.12	Time of Delayed Sleep	5.0	Set based on actual conditions
P9.0.14	PID Reference (Display Value)		Display PID Reference
P9.0.15	PID Feedback (Display Value)		Display PID Feedback
P5.0.19	Factory set values Recovery	00	No Operation
		30	Current User Parameters Backup
		60	User Backup Parameters Recovery
		101	Recovery of Factory set values of Permanent Pressure Water Supply Function
<b>Control Parameters of Pump-increasing</b>			
P2.0.30	Pump-increasing function	00	Enable pump-increasing function
		54	Disable pump-increasing function
P3.2.15	Pump-increasing Connection Delay Time	5.0	Increased pump will be connected after user delay the set value once upper frequency is reached.
P3.2.20	Pump-increasing Disconnection Delay Time	5.0	Increased pump will be disconnected after user delay the set value once lower frequency is reached.

**Performance parameters of permanent water supply**

Function code	Name	Set value	Description
P2.1.02	Analog Input Curve Selection	H.21	Define VF1 Select Curve 1
P2.0.13	Minimum Input of Curve 1	00.00V	Define the relation curve between VF1 Input and PID Feedback <b>NOTE: The default value of inverter's analog input is 0V~10V. If the input is 0 mA~20 mA, it will remain 0V~10V; if the input is 4 mA~20 mA, it will remain 2V~10V.</b>
P2.0.14	Corresponding reference for Minimum Input of Curve 1	000.0%	
P2.0.15	Maximum Input of Curve 1	10.00V	
P2.0.16	Corresponding reference for Maximum Input of Curve 1	100.0%	
P2.0.17	VF1 Filtering time	00.10s	When the site analog is easily disturbed, please increase the filtering time to make the detected analog tend to be stable, but the longer the filtering time is, the response speed to the analog test gets slow as the filtering time become longer.
P4.0.05	Proportional Gains KP1	020.0	The greater the value of proportional gain KP1 is, the larger the adjustment volume is and the faster the response is, but the too large value can generate the system oscillation, the smaller the value of KP1 is, the more stable the system is and the slower the response is.
P4.0.06	Integral Time TI1	02.00	The greater the value of Integral Time TI1 is, the slower the response is and the more stable the output is, the worse the fluctuation control ability of the feedback quantity is, the smaller the value of TI1 is, the faster the response is and the greater the output fluctuation is, the too small value can generate the oscillation.
P4.0.07	Derivative Time TD1	00.000	The Derivative Time TD1 can set the limit for gain provided by the derivator to ensure that a pure derivative gain can be obtained at low frequency and a constant derivative gain can be obtained at high frequency. The longer the derivative time is, the greater the adjusting strength is.

**Generally, no setup is required for the optimized parameters of permanent water supply. If any, please refer to the description of related function code.**

Function code	Name	Set value	Description
P4.0.08	PID Deviation Limit	000.0	Refer to the description of related function code
P4.0.09	PID Feedback Filtering time	00.00	
P4.0.10	Proportional Gains KP2	020.0	
P4.0.11	Integral Time TI2	02.00	
P4.0.12	Derivative Time TD2	00.000	
P4.0.13	PID Switch Conditions	0	
P4.0.14	PID Switch Deviation 1	020.0	
P4.0.15	PID Switch Deviation 2	080.0	
P4.0.16	PID Initial Value	000.0	
P4.0.17	PID Initial Value Hold Time	000.00	
P4.0.18	PID Feedback Loss Test	000.0	
P4.0.19	PID Feedback Loss Test Time	00.0	
P4.0.20	PID Stop Operation	0	

**Monitoring contents under non-operation status:**

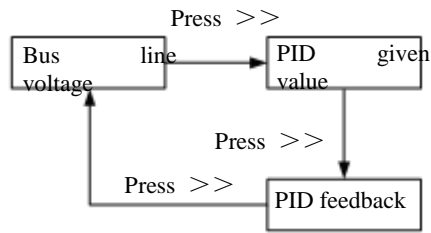

**Monitoring contents under operation status:**

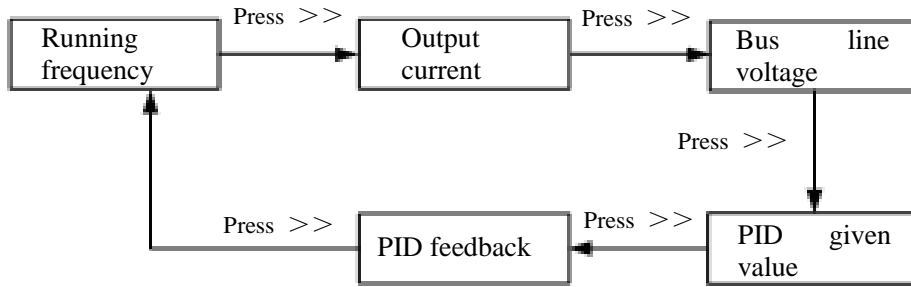

**Factory set values (used for internal function test and no modification is allowed)**

Function code	Set value	Function code	Set value
P0.0.04	8	P3.2.28	04004
P3.2.00	11111	P3.2.29	3224
P3.2.02	780	P3.2.30	1000
P3.2.03	790	P3.2.31	9015
P3.2.04	11106	P3.2.32	9046
P3.2.05	38376	P3.2.34	4004
P3.2.06	1132	P3.2.35	3225
P3.2.09	14	P3.2.36	1000
P3.2.26	H.7353	P3.2.37	9048
P3.2.27	H.0505	P3.2.38	9015
P5.0.05	H.0C02	P5.0.02	H.C015

## 7.2.3 Ball mill

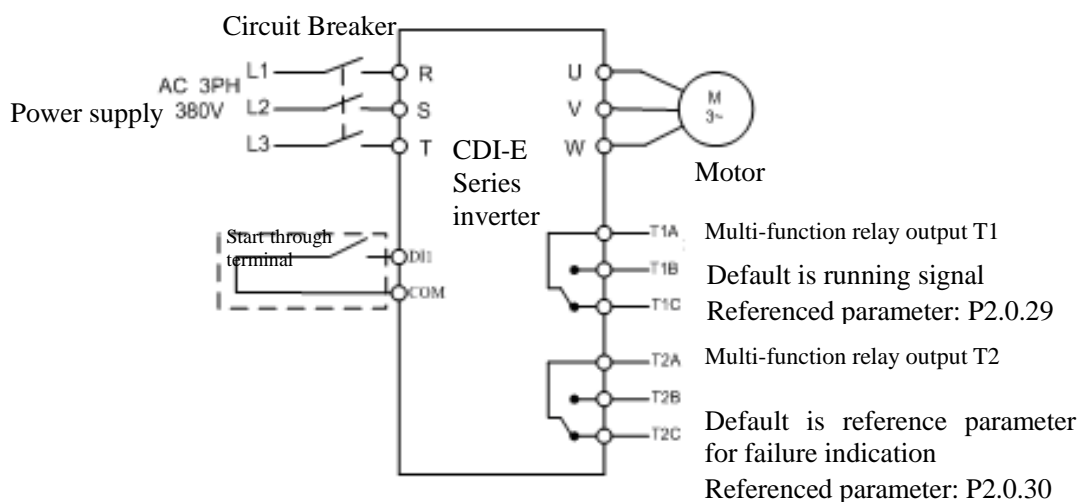
**General parameters of ball mill (when you debug ball mill, please input 102 for function code P5.0.19)**

Function code	Name	Given scope	Factory set value
P0.0.01	Type of Inverter	0: Basic Mode (Prefix with 'P') 1: User Mode (Prefix with 'U') 2: Verification Mode (Prefix with 'C')	1
P0.0.02	Display Mode	0: V/F Control 1: Open-loop Vector Control (SVC) 2: Closed-loop Vector Control (Invalid E100)	0
P0.0.03	Option for Running Control Mode	0: Keyboard Control 1: Terminal Control 2: Communication Control	0
P0.0.11	Acceleration Time	0000.0~6500.0s	Machine type
P0.0.12	Deceleration Time	0000.0~6500.0s	Machine type
P0.1.16	Deceleration Timing	0000.0~6500.0s	Machine type
P3.0.00	Cycle Running Mode	0: End of Single Running and Stop 1: End of Single Running and Save Final Value 2: Continuous Running 3: Cycle N Times	2
P3.0.01	Cycle number (s), N	00000~65000	00000
P3.0.02	Option of PLC Power-off Memory	Memory for shutdown and power-off Ones: Option of Power-off Memory 0: No memory (not saved) 1: Memory (saved) Tens: Option of Shutdown 0: No memory (not saved) 1: Memory (saved)	00

Function code	Name	Given scope	Factory set value
P3.0.04	Phase 0 Running time	0000.0~6500.0 min.	100.0
P3.0.06	Phase 1 Running time	0000.0~6500.0 min.	100.0
P3.0.35	Phase 0 Running direction	H.010: default direction H.110: reversed direction	H.010
P3.0.36	Phase 1 Running direction	H.010: default direction H.110: reversed direction	H.010
P3.0.51	Running Time Unit	0: Second 1: Minute 2: Hour	2
P3.2.11	Control of timed running	4200: not timed 4239: timed	4200
P3.2.17	Waiting Interval Time	0.0~3600.0 sec.	0000
P3.2.24	Total running time	0.0~3600.0 min.	1000.0
P5.0.15	Customized Display of Coefficient	0.0001~6.5000	0.288
P5.0.19	Factory set values Recovery	00: No Operation 30: Current User Parameters Backup 60: User Backup Parameters Recovery 102: Recovery of Factory set values of Ball Mill	00

Notes: 1. The system can be stopped automatically either through cycle numbers or through timing  
 2. Only the above parameters will be displayed and other parameters will be hidden when you switch to user mode (P0.0.01=1).  
 3. If the running direction of Phase 0 and Phase 1 is same, which means single direction running; if the running direction of Phase 0 and Phase 1 is opposite, which means alternative direction running  
 4. If vector control, please refer to User Manual (default is V/F control) of motor parameters setting and parameters identification.

**Illustration of system running**

Running direction of Phase 0 and Phase 1 is same.

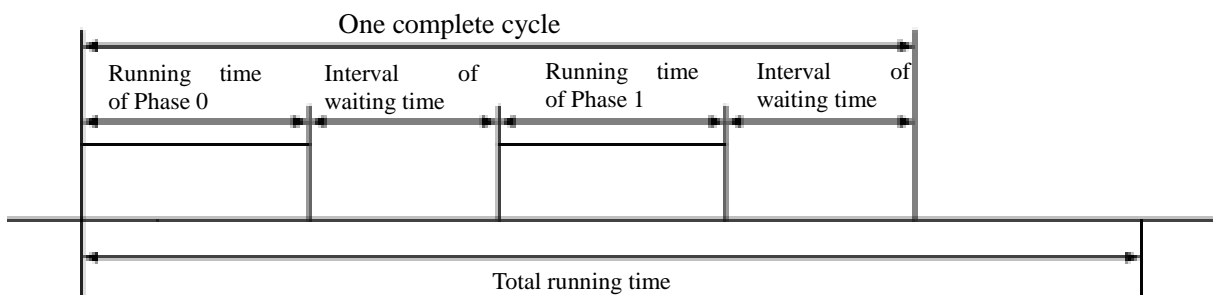

If the running is not timed, the system will run one cycle after one cycle until a stop instruction is received. If the running is timed, the system will stop automatically once the total running time is reached.

Running direction of Phase 0 and Phase 1 is opposite.

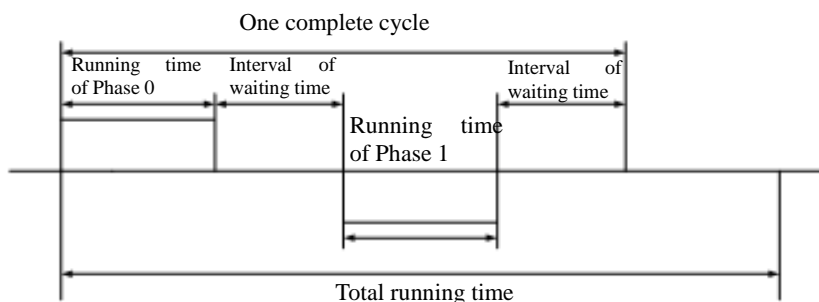

If the running is not timed, the system will run one cycle after one cycle until a stop instruction is received. If the running is timed, the system will stop automatically once the total running time is reached.

**Method of rotating speed indicating**

If you want to display rotating speed, you can calculate the customized display constant according to the following formula and set the calculation result in P5.0.15. And then press >>, once V, A, Hz on the keyboard panel are black out, the figure displayed is rotating speed.

$$\text{Customized display constant} = \text{Rated rotating speed} / (\text{rated frequency} * 100) / \text{speed ratio}$$

For example: the rated rotating speed of motor is 1444 rpm, rated frequency is 50.00Hz and the speed ratio of machine is 2, so Customized display constant = 1444 / (50.00 \* 100) / 2 = 0.144

**Monitoring contents under shutdown status**

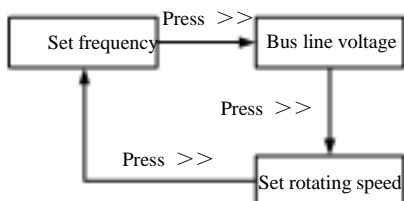

**Monitoring contents under running status:**

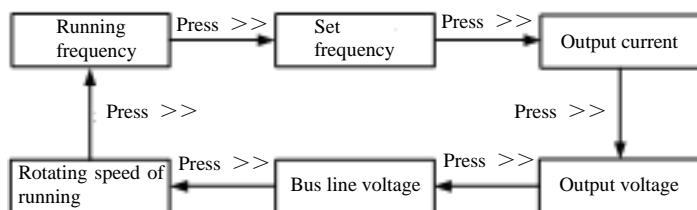

**Factory set values (used for internal function test and no modification is allowed)**

Function code	Set value	Function code	Set value	Function code	Set value
P0.0.04	7	P3.2.09	0048	P3.2.04	21113
P3.2.00	21112	P3.2.05	121	P5.0.05	H.0203
P3.2.07	3914	P3.2.10	0050	P5.0.02	H.081F
P3.2.03	00100	P3.2.23	10001		
P3.2.18	1.0	P3.0.51	2		

7.2.4 Injection Molding Machine

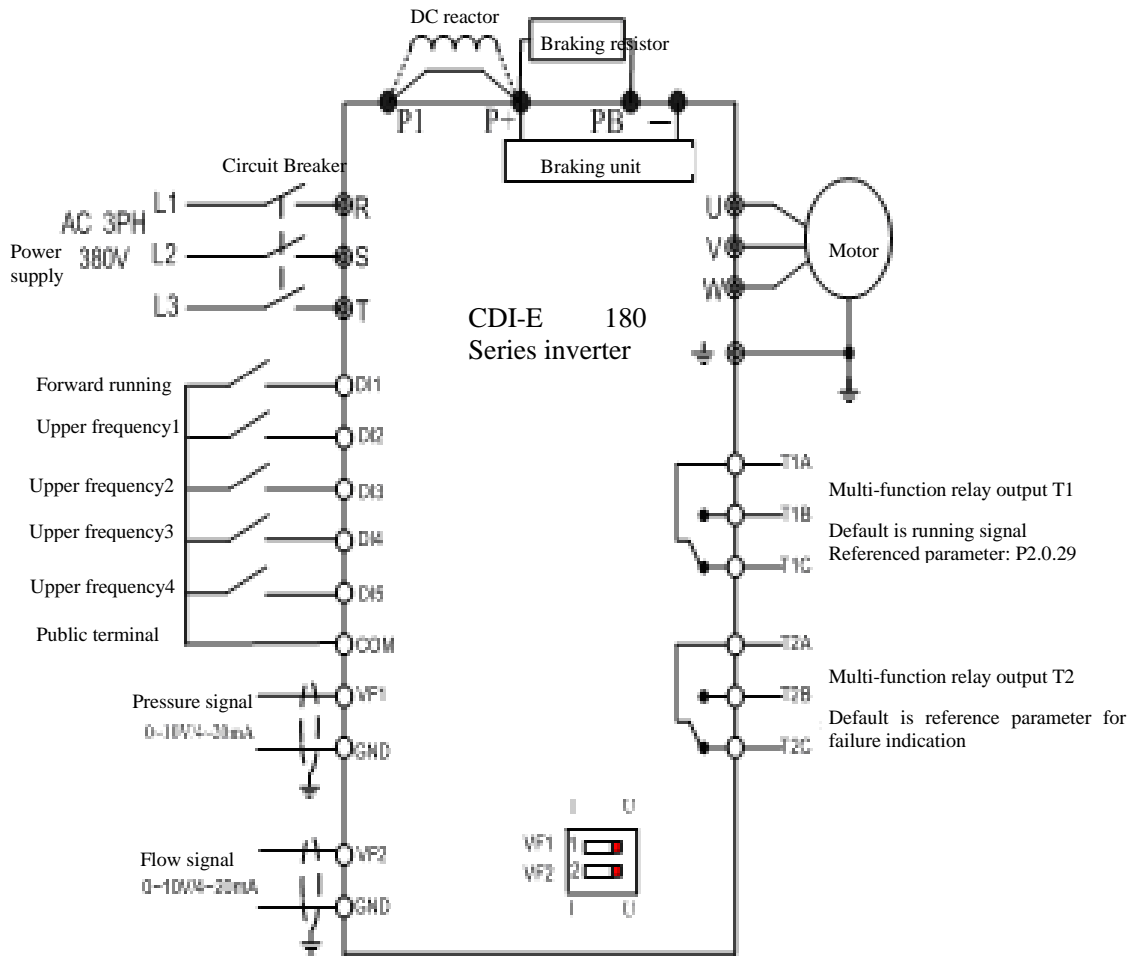

Note: if analog input is 0~10V, then voltage signal will switch J5-1 & J5-2 (VF1, VF2 DIP switch) to U side; if analog input is 4~20mA, then voltage signal will switch J5-1 & J5-2 to I side; if analog input is 0~1A current signal, you should increase an E180-ZS expansion card to convert current signal into 0~10V voltage signal. Please see Appendix 6 for the use instruction of E180-ZS expansion card.

**Wiring connection of main circuit of variable frequency (VF) energy-saving reconstruction of Injection Molding Machine**

As for Injection Molding Machine with direct START/STOP oil pump motor, the wiring connection is as follows:



When make reconstruction, connect the power cable from the back of circuit breaker to in-line terminal of inverter, and connect in-line terminal of electromagnetic switch to out-line terminal of inverter.

As for Injection Molding Machine with oil pump motor via reduced-voltage START, the wiring connection is as follows:

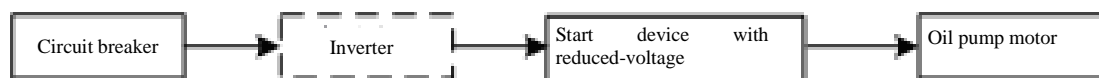

When make reconstruction, connect the power cable from the front of bus line of START device with reduced-voltage or back of circuit breaker to in-line terminal of inverter, and connect out-line terminal of inverter to in-line terminal of main circuit of START device with reduced-voltage.

**General parameters of Injection Molding Machine (when you debug Injection Molding Machine, please input 103 for function code P5.0.19)**

Function code	Name	Set value	Description	
P0.1.00	Option of Frequency Source	0	VF1 (default)	
		1	VF2	
		2	VF1+ VF2	
		4	MAX[VF1, VF2]	
P0.0.09	Lower frequency	10.00Hz	The lowest running frequency is allowed by inverter	
P0.0.11	Acceleration Time	Machine type		
P0.0.12	Deceleration Time	Machine type		
P2.1.04	Min. Input of VF1	00.00V	<p>Relation curve of VF input and corresponding reference. The corresponding reference means percentage of the highest frequency.</p>	
P2.1.05	Corresponding reference for Min. Input of VF1	000.0%		
P2.1.10	Max. Input of VF1	10.00V		
P2.1.11	Corresponding reference for Max. Input of VF1	100.0%		
P2.1.12	Min. Input of VF2	00.00V		
P2.1.13	Corresponding reference for Min. Input of VF2	000.0%		
P2.1.18	Max. Input of VF2	10.00V		
P2.1.19	Corresponding reference for Max. Input of VF2	100.0%		
P6.1.06	Fault Auto Reset Number	00		No automatic fault reset
P6.1.07	Waiting Interval Time of Fault Auto Reset	001.0s		Refer to the waiting time of automatic fault reset after the inverter gives an alarm of fault.
P3.2.08	Limitless Fault Auto Reset	0200	Invalid	
		0213	Valid	
P3.2.13	Waiting Interval Time of Limitless Fault Auto Reset	001.0s	Refer to the waiting time of automatic fault reset after the inverter gives an alarm of fault.	
P5.0.19	Factory set values Recovery	00	No Operation	
		30	Current User Parameters Backup	
		60	User Backup Parameters Recovery	
		103	Recovery of Factory set values of Injection Molding Machine	

**Performance Parameters of Injection Molding Machine**

P2.1.06	VF1 Inflection Point 1 Input	03.00V	<p>Relation curve of VF input and corresponding reference. The corresponding reference means percentage of the highest frequency.</p>	
P2.1.07	Corresponding reference for VF1 Inflection Point 1 Input	030.0%		
P2.1.08	VF1 Inflection Point 2 Input	06.00V		
P2.1.09	Corresponding reference for VF1 Inflection Point 2 Input	060.0%		
P2.1.14	VF2 Inflection Point 1 Input	03.00V		
P2.1.15	Corresponding reference for VF2 Inflection Point 1 Input	030.0%		
P2.1.16	VF2 Inflection Point 2 Input	06.00V		
P2.1.17	Corresponding reference for VF2 Inflection Point 2 Input	060.0%		
P3.0.03	Phase directive 0	100.0%		Upper frequency when DI5, DI4, DI3, DI2 are disconnected (percentage of the highest frequency)
P3.0.05	Phase directive 1	090.0%		Upper frequency only when DI2 is connected (ditto)
P3.0.07	Phase directive 2	080.0%	Upper frequency only when DI3 is connected (ditto)	
P3.0.11	Phase directive 4	070.0%	Upper frequency only when DI4 is connected (ditto)	
P3.0.19	Phase directive 8	060.0%	Upper frequency only when DI5 is connected (ditto)	
P2.0.17	VF1 Filtering time	0.10s sec.	when the on-site analog is easily to be disturbed, the filtering time shall be increased to make the tested analog input to be stable, but the greater filtering time makes the response speed of the analog test become slow.	
P2.0.22	VF2 Filtering time	0.10 sec.		

**Factory set values (used for internal function test and no modification is allowed)**

Function code	Set value	Function code	Set value
P0.0.03	1	P2.0.02	10
P0.0.04	3	P2.0.03	11
P0.1.01	4	P2.0.04	12
P0.0.07	50.00Hz	P2.1.02	H.43
P0.0.10	0	P3.2.00	00022
P0.1.03	3	P3.2.07	3714
P2.0.00	01	P2.0.01	9

## 7.2.5 Local/ Remote Control

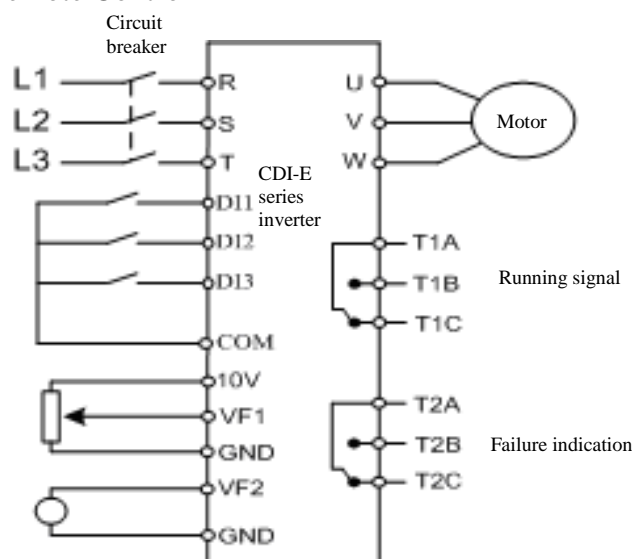

- Notes:
1. VF1 is local analog input
  2. VF2 is remote analog input
  3. DI1 is local button of START/ STOP (START is connected while STOP is disconnected)
  4. DI2 is remote button of START/ STOP (START is connected while STOP is disconnected)
  5. DI3 is switch button of LOCAL/ REMOTE (REMOTE is connected while LOCAL is disconnected)

**General parameters for local/ remote control (when you debug local/ remote control, please input 104 for function code P5.0.19)**

Function code	Description
P0.0.03	Running command control method: P0.0.03=1 and P3.2.07=0021: keyboard control of local and terminal DI2 control for remote (default) P0.0.03=1 and P3.2.07=0000: Terminal DI1 control for local and terminal DI2 control for remote
	P0.0.03=2 and P3.2.07=0021: keyboard control of local and communication control for remote P0.0.03=2 and P3.2.07=0022: Terminal DI1 control for local and communication control for remote
P0.0.04	Local frequency resource method selection 0~13, 02: Keyboard potentiometer (default)
P0.1.01	Remote frequency resource method selection 10~13, 04: VF2 (default)
P5.0.19	30: Users Current Parameter Backup
	60: User Backup Parameters Recovery
	104: Factory set values of Local/ Remote function recovery

**Factory set values (used for internal function test and no modification is allowed)**

Function code	Set value	Function code	Set value	Function code	Set value
P0.0.03	1	P2.0.01	00	P3.2.03	00102
P0.1.00	8	P2.0.02	18	P3.2.04	01022
P0.1.01	4	P3.2.00	1111	P3.2.05	11123
P2.0.00	0	P3.2.02	00021	P3.2.10	01

## Chapter 8 E Series Frequency Inverter RS-485 Communication

### 1 Explanation for E Series Frequency inverter RS-485 Communication Terminal

CDI-E100, E102 Series Frequency inverters have had RS-485 Communication Terminal on control panel.

SG+:485 Signal Positive

SG-:485 Signal Negative

CDI-E180 Series Frequency inverter hasn't had RS-485 Communication Terminal on control panel. If the communication is required, the external expansion card must be connected.

### 2 Explanation for E Series Frequency inverter Communication Parameter

Before the use of RS-485 Communication, must use the keyboard to set "Baud Rate", "Data Format" and "Communication Address".

Function code	Function name	Setting scope	Factory set value
P4.1.00	Baud Rate	0:1200 1:2400 2:4800 3:9600 4:19200 5:38400 6:57600	3
P4.1.01	Data Format	0:No Verification (8-N-2) 1:Even Parity Verification (8-E-1) 2:Odd Parity Verification (8-O-1) 3:No Verification (8-N-1)	0
P4.1.02	Local Machine Address	000:Broadcast Address 001~249	1
P4.1.03	Response Delay	00~20ms	2
P4.1.04	Communication Timeout	00.0 (Invalid) 00.1s~60.0s	0.0
P4.1.05	Data Transmission Format	0:ASCII Mode (Reservation) 1:RTU Mode	1
P4.1.06	MODBUS communication data reply or not	0: Reply    1: No reply	0

**Response Delay:** when the frequency inverter receives the data and after the time set by Function Code P4.1.03 is delayed, the frequency inverter starts recovering the data.

**Communication Timeout:** the interval between data frames received by the frequency inverter is over the time set by Function Code P4.1.04, the frequency inverter gives an alarm of Fault Err14, it is deemed as abnormal communication. If it is set at 0.0, the communication timeout is invalid.

3 Description for Standard MODBUS Communication Format

3.1 String Structure

(8-N-2, P4.1.01=0)

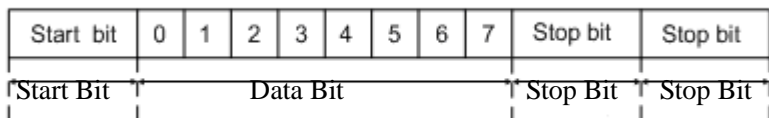

(8-E-1, P4.1.01=1)

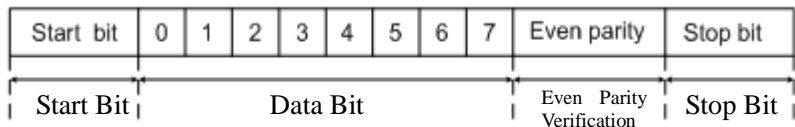

(8-O-1, P4.1.01=2)

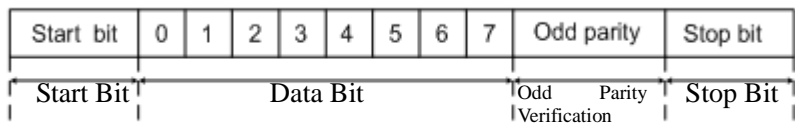

(8-N-1, P4.1.01=3)

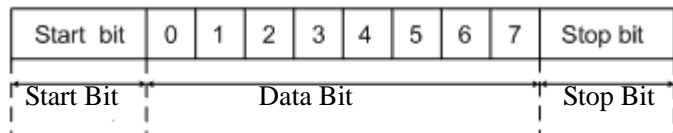

## 3.2 Communication Data Structure

ADR	Slave Machine (Frequency inverter) Address The address scope of the frequency inverter is (001~249), ( 8-digit hexadecimal number) <b>Note:</b> When the address is ADR=000H, it is valid for all slave machines and all slave machines can't respond message (broadcast mode)
CMD	Function Code of Data Package (06: write the contents of a register; 03: read out the contents of one or more than one register(s)) (8-digit hexadecimal number)
ADDRESS	Sending of Host Machine: when at Function Code 06, it means data address (16-digit hexadecimal number); when at Function Code 03, it means data initial address (16-digit hexadecimal number) Slave Station Responds: refer to data address when at function code 06 (16-digit hexadecimal number); refer to data number when at function code 03
DATA	Sending of Host Machine: when at Function Code 06, it means data address (16-digit hexadecimal number); when at Function Code 03, it means data initial address (16-digit hexadecimal number) Slave Station Responds: when at Function Code 06, it means data address (16-digit hexadecimal number); when at Function Code 03, it means data initial address (16-digit hexadecimal number in N)
CRC	CHK (CHECKSUM) (16-digit hexadecimal number)

RTU adopts CRC CHK (CHECKSUM), which is calculated as per the following steps:

Step 1: Load 16-digit register with content of FFFFH (CRC Register).

Step 2: Conduct XOR operation for the first byte of the communication data and the contents of CRC Register and store the results into CRC Register.

Step 3: Move 1bit of the contents of CRC Register to the minimum significant bit and fill in 0 to the maximum significant bit, and check the minimum significant bit of CRC Register.

Step 4: If the minimum significant bit is 1, the CRC Register and preset value conduct XOR operation. If the minimum significant bit is 0, no action is taken.

Step 5: After repeat 8 times of Step 3 and 4, the handling to this byte is finished.

Step 6: Repeat Step 2-5 for next byte of the communication data until the handling to all bytes are completed, the final content of CRC Register is the value of CRC. When transmitting CRC Value, first add the low byte and then high byte, that is, the low byte is first transmitted.

In case of any fault of the communication, the slave machine responds the data of ADDRESS and DATA are as below:

ADDRESS	DATA	Description	ADDRESS	DATA	Description
FF01	0001	Invalid address	FF01	0005	Invalid parameter
FF01	0002	CRC Check Error	FF01	0006	Invalid Modification to Parameter
FF01	0003	Read and Write Command Error	FF01	0007	System Lock
FF01	0004	Password Error	FF01	0008	Parameter under Storage

The master station writes the command string format:

Name of Character	Slave Station	Write Command 06H	Function Code Address	Data content	CRC Check
Length of Character	1Byte	1Byte	2Byte	2Byte	2Byte
Example	01H	06 H	0005 H	1388H	949DH

The slave station responds the command string format:

Name of Character	Slave Station	Write Command 06H	Function Code Address	Data content	CRC Check
Length of Character	1Byte	1Byte	2Byte	2Byte	2Byte
Example	01H	06 H	0005 H	1388H	949DH

The master station reads the command string format:

Name of Character	Slave Station	Read Command 03H	Initial Address of Function Code	Data content	CRC Check
Length of Character	1Byte	1Byte	2Byte	2Byte	2Byte
Example	01H	03 H	9000 H	0003H	28CBH

The slave station responds the read command string format:

Name of Character	Slave Station	Read Command 03H	Data content 1	Data content 2	Data content 3	CRC Check
Length of Character	1Byte	1Byte	2Byte	2Byte	2Byte	2Byte
Example	01H	03 H	0000H	0000H	0000H	2175H

The slave station responds the write command error string format:

Name of Character	Slave Station	Write Command 06H	Read and Write Error Mark	Read and Write Error Type	CRC Check
Length of Character	1Byte	1Byte	2Byte	2Byte	2Byte
Example	01H	03 H	FF01 H	0005H	281DH

The slave station responds the read command error string format:

Name of Character	Slave Station	Read Command	Read and Write Error Mark	Read and Write Error Type	CRC Check
Length of Character	1Byte	1Byte	2Byte	2Byte	2Byte
Example	01H	03 H	FF01H	0005H	E41DH

#### 4 Definition for Parameter Address of Communication Protocol

E Series Frequency inverter not only has many multifunctional function code parameters, but some non-multifunctional function code parameters. Specific read and write properties are as below:

Function Code Parameter	P1~P8	Readable, writable
	P9	Only Readable
Non-function Code Parameter	A000H, A001H, A002H, A003H, A004H, A005H, A010H, A011H	Only writable
	B000H, B001H	Only Readable

#### Explanation for Read and Write Address of Function Code Parameters:

High-order parameter address is composed of groups and levels by the function code parameters.

For the service life of EEPROM is limited, the EEPROM cannot be stored frequently in the process of communication. Therefore, some function codes don't need to be stored in EEPROM in the process of communication, but only need to modify the value in RAM.

If it is required to write them into EEPROM, the high-order parameter address adopts the hexadecimal number and low parameter address adopts decimal number that then is converted to the hexadecimal number. And then the high-order and low-order parameter address constitutes a four-digit hexadecimal number.

E.g. The address of writing P2.1.12 to EEPROM is as below:

High-order address is 21 by hexadecimal system and lower-order address is 12 by decimal system, which is 0C after conversion into hexadecimal system, so the address indicates 0x210C.

If it is not required to write it into EEPROM, the high-order parameter address adopts hexadecimal number and adds 4 digits, and low-order parameter address adopts decimal number then is converted to the hexadecimal number. And then the high-order and low-order parameter address constitutes a four-digit hexadecimal number.

E.g. The address of not writing P2.1.12 to EEPROM is as below:

High-order address is 21 by hexadecimal system and then adds 4 digits, that is, 25. The lower-order address is 12 by decimal system, which is 0C after conversion into hexadecimal system, so the address indicates 0x250C.

Table of Definitions for Non-functional Function Code Parameter Address

Definition	Function Code	Parameter Address	Description for Function		
Command to Frequency inverter	06H	A000H	0001H	Forward Run	
			0002H	Reverse Run	
			0003H	Forward Jogging	
			0004H	Reverse Jogging	
			0005H	Free Stop	
			0006H	Shutdown By Speed Reduction	
			0007H	Fault Rest	
		A001H	Frequency Command or Upper Frequency Source (refer to the percentage of the highest frequency without storage) (00.00~100.00 indicates 00.00%~100.00%)		
		A002H	BIT0	Multi-functional Output Terminal YO1 (valid only when E180 adds I/O expansion card, E100 is invalid)	
			BIT1	Multi-functional Output Terminal YO2 (valid only when E180 adds I/O expansion card, E100 is invalid)	
			BIT2	Multi-functional Output Terminal T1	
			BIT3	Multi-functional Output Terminal T2	
			BIT4	Multi-functional Output Terminal YO (when Terminal YO/FMP is used as YO, that is, P2.1.20=1)	
				If it is required to make multi-functional output terminal valid, set corresponding position to 1, after transfer binary system to hexadecimal system, send it to address A002.	
		A003H	FM1 Output Address (00.0~100.0 indicates 00.0%~100.0%)		
A004H	FM2 Output Address (00.0~100.0 indicates 00.0%~100.0%)				
A005H	FMP Output Address (when Terminal YO/FMP is used as FMP, that is, P2.1.20=0) (0000H~7FFFH indicates 0.00%~100.00%)				
A010H	PID Reference Value				
A011H	PID Feedback Value				
Running status of monitoring frequency inverter	03H	B000H	0001H	Forward Run	
			0002H	Reverse Run	
			0003H	Stop	

**Table of Definitions for Non-functional Function Code Parameter Address**

Definition	Function Code	Parameter Address	Description for Function	
Monitoring to Fault of Frequency inverter	03H	B001H	00	No fault
			01	Over-current at constant speed
			02	Over-current at acceleration
			03	Over-current at deceleration
			04	Over-voltage at constant speed
			05	Over-voltage at acceleration
			06	Over-voltage at deceleration
			07	Module Fault
			08	Undervoltage
			09	Frequency inverter Overload
			10	Motor Overload
			11	Input Default Phase
			12	Output Default Phase
			13	External Fault
			14	Abnormal Communication
			15	Frequency inverter Overheat
			16	Hardware Fault of Frequency inverter
			17	Motor Earthing Short Circuit Motor
			18	Motor Identification Error
			19	Motor Off-load
			20	PID Feedback Loss
			21	User-Defined Fault 1
			22	User-Defined Fault 2
			23	Accumulative Power-on Time Reached
			24	Accumulative Running Time Reached
			25	Encoder Fault
			26	Parameter Read-Write Abnormity
			27	Motor Overheat
			28	Larger Speed Deviation
			29	Motor Overspeed
			30	Initial Position Error
			31	Current Test Fault
			32	Contactior
			33	Abnormity of Current Test
			34	Fast Current-limiting Timeout
			35	Motor Switch at Running
			36	24V Power Fault
			37	Driving Power Supply Fault
			40	Buffer Resistance Fault

## 5 Example

## E.g. 1. Forward Start No.1 Frequency inverter

The host machine sends data package

ADR	01H
CMD	06H
ADDRESS	A0H
	00H
DATA	00H
	01H
CRC	6AH
	0AH

The slave machine responds the data package

ADR	01H
CMD	06H
ADDRESS	A0H
	00H
DATA	00H
	01H
CRC	6AH
	0AH

## E.g. 2. Reference No.1 Frequency inverter Frequency (Not store)

The frequency value of Reference 1# Frequency inverter is the highest frequency 100.00%.

Methods are as below: after removal of the decimal point of 100.00, it is 10000D=2710H.

The host machine sends data package

ADR	01H
CMD	06H
ADDRESS	A0H
	01H
DATA	27H
	10H
CRC	E0H
	36H

Respond the data package

ADR	01H
CMD	06H
ADDRESS	A0H
	01H
DATA	27H
	10H
CRC	E0H
	36H

## E.g. 3. Inquire the running frequency of No.1 Frequency inverter Frequency

In running state, inquire the “Output Frequency” of the Frequency inverter 1#

Methods are as below: the Function Code Parameter No. of the output frequency is P9.0.00, after conversion into address, it is 9000H.

If the “Output Frequency” of the Frequency inverter 1# is 50.00Hz, it is 5000D=1388H

The host machine sends data package

ADR	01H
CMD	03H
ADDRESS	90H
	00H
DATA	00H
	01H
CRC	A9H
	0AH

The slave machine responds the data package

ADR	01H
CMD	03H
ADDRESS	02H
DATA	13H
	88H
CRC	B5H
	12H

## Chapter 9 Fault Handling

## 9.1 Frequency inverter Fault and Exclusion Measure

Fault display	Description	Details	Fault elimination
Err00	No Fault		
Err01	Over-current at constant speed	The output current exceeds the over-current value while the frequency inverter is running at a constant speed	<ul style="list-style-type: none"> <li>● Check whether the output circuit of the frequency inverter has short circuit;</li> <li>● Check whether the input voltage is relatively low;</li> <li>● Check whether the load has mutation;</li> <li>● Conduct parameter identification or improve low frequency torque compensation;</li> <li>● Check whether the rated power of the motor or frequency inverter is large enough;</li> </ul>
Err02	Over-current at acceleration	When the frequency inverter accelerates, output current exceeds overcurrent	<ul style="list-style-type: none"> <li>● Check whether the motor is and its lines are short circuit, grounded or too long;</li> <li>● Check whether the input voltage is relatively low;</li> <li>● Delay the acceleration time</li> <li>● Conduct parameter identification or improve low frequency torque compensation or adjust V/F Curve;</li> <li>● Check whether the load has mutation;</li> <li>● Check whether it is to select speed tracking or start after the motor stops stably;</li> <li>● Check whether the rated power of the motor or frequency inverter is large enough;</li> </ul>
Err03	Over-current at deceleration	When the frequency inverter decelerates, output current exceeds overcurrent	<ul style="list-style-type: none"> <li>● Check whether the motor is and its lines are short circuit, grounded or too long;</li> <li>● Conduct parameter identification</li> <li>● Delay the deceleration time;</li> <li>● Check whether the input voltage is relatively low;</li> <li>● Check whether the load has mutation;</li> <li>● Install additional brake unit and brake resistance;</li> </ul>
Err04	Over-voltage at constant speed	When the frequency inverter runs at constant speed, DC voltage of the main circuit exceeds this set value. Detected DC overvoltage value: Level T2 : 400V Level T4: 750V Level T6: 1300V	<ul style="list-style-type: none"> <li>● Check whether the input voltage is too high;</li> <li>● Check whether the Bus line voltage display is normal;</li> </ul> <p>Check whether the motor is dragged to run by external force in the running process;</p>

Fault display	Description	Details	Fault elimination
Err05	Over-voltage at acceleration	When the frequency inverter runs at constant speed, DC voltage of the main circuit exceeds this set value. The tested overvoltage value is the same as above.	<ul style="list-style-type: none"> <li>● Check whether the input voltage is too high;</li> <li>● Check whether the Bus line voltage display is normal;</li> <li>● Delay the deceleration time;</li> <li>● Check whether the motor is dragged to run by external force in the process of deceleration;</li> <li>● Install additional brake unit and brake resistance;</li> </ul>
Err06	Over-voltage at deceleration	When the frequency inverter runs at constant speed, DC voltage of the main circuit exceeds this set value. The tested overvoltage value is the same as above.	<ul style="list-style-type: none"> <li>● Check whether the input voltage is too high;</li> <li>● Check whether the Bus line voltage display is normal;</li> <li>● Delay the deceleration time;</li> <li>● Check whether the motor is dragged to run by external force in the process of deceleration;</li> <li>● Install additional brake unit and brake resistance;</li> </ul>
Err07	Module fault	External fault has triggered automatic module protection	<ul style="list-style-type: none"> <li>● Check the coil resistance of the motor;</li> <li>● Check the isolation of the motor;</li> <li>● Damage by inverse module breakdown;</li> </ul>
Err08	Under-voltage	Under-voltage in the main circuit, check the electric level: Test DC undervoltage value: Level T2 : 190V Level T4: 380V Level T6: 700V	<ul style="list-style-type: none"> <li>● Check the lines of supply power contact well;</li> <li>● Check whether the incoming voltage is within regulated scope;</li> <li>● Check whether there is momentary interruption;</li> <li>● Check whether the display of the Bus line voltage is normal;</li> <li>● Check whether the setting bridge and charge resistance are normal;</li> </ul>
Err09	Frequency inverter overloaded	Motor and current exceed the rated load	<ul style="list-style-type: none"> <li>● Check whether the motor is in locked-rotor conditions or the load to motor needs to be reduced;</li> <li>● Replace the frequency inverter with larger power;</li> </ul>
Err10	Motor overload	Motor and current exceed the rated current	<ul style="list-style-type: none"> <li>● Check the protection parameter P1.0.25 Reference of the motor is proper;</li> <li>● Check whether the motor is in locked-rotor conditions or the load to motor needs to be reduced;</li> <li>● Correctly preset the rated current of the motor;</li> <li>● Replace the frequency inverter with larger power;</li> </ul>
Err11	Missing phase	Error of missing phase or unbalanced three phases	<ul style="list-style-type: none"> <li>● Check main circuit voltage whether it is missing phase or unbalanced three phases</li> <li>● Check whether the connecting terminal is loosing.</li> <li>● Seek technical support</li> </ul>

Fault display	Description	Details	Fault elimination
Err12	Output Default Failure	Output Default Failure or 3-phase Imbalance Fault	<ul style="list-style-type: none"> <li>● Check whether the output circuit has output default failure or 3-phase imbalance fault</li> <li>● Check whether the wiring terminals are loose</li> <li>● Seek technical support</li> </ul>
Err13	External Fault	Fault caused by External Control Circuits	<ul style="list-style-type: none"> <li>● Check the signal input circuit of external fault</li> <li>● Reset Run</li> </ul>
Err14	Abnormal Communication	Abnormity for communication of frequency inverter and other equipments	<ul style="list-style-type: none"> <li>● Check external communication lines</li> <li>● The upper computer doesn't work normally</li> <li>● The setting for communication parameter is not correct</li> <li>● The communication protocol is inconsistent</li> </ul>
Err15	Frequency inverter Overheat	Radiator temperature $\geq$ oh Test Value (about 80°C, to temperature switch)	<ul style="list-style-type: none"> <li>● Check the running state of the fan and ventilation state</li> <li>● Check whether the surrounding temperature is too high and the cooling measures are required to be taken;</li> <li>● Check whether the thermistor or temperature switch is damaged;</li> <li>● Clear the dirt on the exterior of radiator and air intake;</li> </ul>
Err16	Hardware Fault of Frequency inverter	In case of overcurrent or overvoltage existed in frequency inverter, it is judged as hardware fault	<ul style="list-style-type: none"> <li>● Handle as overcurrent and overvoltage fault</li> </ul>
Err17	Motor-to-ground short circuit	Motor-to-ground short circuit	<ul style="list-style-type: none"> <li>● Check whether the output line or motor of the frequency inverter has ground short circuit</li> </ul>
Err18	Motor Identification Error	When conducting the parameter identification, the fault occurs in motor	<ul style="list-style-type: none"> <li>● Check whether the motor parameter is consistent with the nameplate of the motor</li> <li>● Whether the frequency inverter and main cable of the motor are connected well;</li> </ul>
Err19	Motor Off-load	Refer to the value of running current less than off-load current P6.1.19 and duration of P6.1.20	<ul style="list-style-type: none"> <li>● Check whether the load separates;</li> <li>● Check whether the value set by Parameter P6.1.19 and P6.1.20</li> </ul>
Err20	PID Feedback Loss	Refer to the value of PID feedback value less than value of P4.0.18 and duration of P4.0.19	<ul style="list-style-type: none"> <li>● Check whether PID Feedback Signal is normal</li> <li>● Check whether the value set by Parameter P4.0.18 and P4.0.19 meets actual running conditions;</li> </ul>

Fault display	Description	Details	Fault elimination
Err21	User-Defined Fault 1	Fault 1 Signal given by the users through multi-functional terminals or PLC Programming Function	<ul style="list-style-type: none"> <li>● Check whether the User-Defined Fault 1 is removed and then run after reset;</li> </ul>
Err22	User-Defined Fault 2	Fault 2 Signal given by the users through multi-functional terminals or PLC Programming Function	<ul style="list-style-type: none"> <li>● Check whether the User-Defined Fault 2 is removed and then run after reset;</li> </ul>
Err23	Accumulative Power-on Time Reached	Refer to the time given by accumulative power-on Time Reached P5.1.01 of the frequency inverter	<ul style="list-style-type: none"> <li>● Use the parameter initialization function to clear the record information</li> </ul>
Err24	Accumulative Running Time Reached	Refer to the time given by accumulative power-on Time Reached P5.1.00 of the frequency inverter	<ul style="list-style-type: none"> <li>● Use the parameter initialization function to clear the record information</li> </ul>
Err25	Encoder Fault	The frequency inverter is unable to identify the data of the encoder	<ul style="list-style-type: none"> <li>● Check whether the type of the encoder matches</li> <li>● Check whether the wiring connection of the encoder is correct</li> <li>● Check whether the encoder or PG card is damaged;</li> </ul>
Err26	Parameter Read-Write Abnormity	Damage of EEPROM Chip	<ul style="list-style-type: none"> <li>● Change main control panel</li> </ul>
Err27	Motor Overheat	Test on excessive temperature of the motor	<ul style="list-style-type: none"> <li>● Check whether the temperature of the motor is too high;</li> <li>● Check whether the temperature sensor is damaged or its wirings are loose;</li> </ul>
Err28	Larger Speed Deviation	Refer to the value of speed deviation larger than P6.1.23 and duration of P6.1.24	<ul style="list-style-type: none"> <li>● Check whether the parameters of the encoder is set correctly;</li> <li>● Check whether P6.1.23 and P6.1.24 are set rationally;</li> <li>● Check whether the motor parameter identification has been conducted;</li> </ul>
Err29	Motor Overspeed	Refer to the value of motor speed over P6.1.21 and duration of P6.1.22	<ul style="list-style-type: none"> <li>● Check whether the parameters of the encoder is set correctly;</li> <li>● Check whether P6.1.21 and P6.1.22 are set rationally;</li> <li>● Check whether the motor parameter identification has been conducted;</li> </ul>
Err30	Initial Position Error	Large deviation between motor parameters and actual parameters	<ul style="list-style-type: none"> <li>● Check whether the motor parameters are correct, especially for rated current of the motor;</li> </ul>

Fault display	Description	Details	Fault elimination
Err31	Current Test Fault	Circuit fault after current test	<ul style="list-style-type: none"> <li>● Check whether the Hall device has defaults;</li> <li>● Check whether the circuit has fault after test of the driver board;</li> <li>● Check whether the driver board has fault;</li> </ul>
Err32	Contactors	Abnormal power supply of driver board caused by the fault of the contactor	<ul style="list-style-type: none"> <li>● Check whether the contactor is normal;</li> <li>● Check whether the power supply of the driver board is normal;</li> </ul>
Err33	Abnormity of Current Test	Circuit fault after current test leads to abnormal current test value	<ul style="list-style-type: none"> <li>● Check whether the Hall device has defaults;</li> <li>● Check whether the circuit has fault after test of the driver board;</li> <li>● Check whether the driver board has fault;</li> </ul>
Err34	Fast Current-limiting Timeout	The running current of the frequency inverter continues to be larger, which exceeds allowable current-limit time	<ul style="list-style-type: none"> <li>● Check whether the load is too large or is stalled;</li> <li>● Check whether the size of the frequency inverter is too small;</li> </ul>
Err35	Motor Switch at Running	Conduct motor switch in the running process of the frequency inverter	<ul style="list-style-type: none"> <li>● Conduct the switch operation of the motor after shutdown of the frequency inverter;</li> </ul>
Err36	Power Fault	External 24V power supply is short circuit or the load of External 24V power supply is too large	<ul style="list-style-type: none"> <li>● Check whether external 24V power supply is short circuit;</li> <li>● Reduce the load of external 24V power supply;</li> </ul>
Err37	Driving Power Supply Fault	Driving Power Supply Fault for Model G250T4 and above	<ul style="list-style-type: none"> <li>● Check whether driving power supply in driver board is normal;</li> </ul>
Err38	Output short circuit	3-phase output inter-phase short circuit	<ul style="list-style-type: none"> <li>● Check insulation of motor wire and motor</li> </ul>
Err40	Buffer Resistance	The Bus line voltage fluctuates strongly	<ul style="list-style-type: none"> <li>● Check whether the contactor is normal;</li> <li>● Check the fluctuations of incoming voltage;</li> </ul>

## 9.2 Motor Fault and Exclusion Measure

If any of the faults below occurs to your motor, find out the causes and take corresponding corrective measures. If the fault persists, please contact your DELIXI distributor immediately.

Motor Fault and Its Elimination:

Fault	Tips for checking	Corrective measures
The motor does not rotate.	Has the power voltage been delivered to the terminals R, S and T?	Switch on the power supply; switch it off and on again; check power voltage; make sure the terminal bolts have been tightened
	Measure the voltages of terminals U, V and W with a rectifier-type voltmeter. Are they right?	Cut off power supply and switch it on again
	Has the motor been locked due to overload?	Reduce load and lift the lock
	Is there any fault information displayed on the monitor of the operator?	Check the fault according to the table of faults
	Has the instruction for forward or reverse rotation been fed in?	Check the wiring
	Has the frequency-setting signal been fed in?	Change the wiring, check the frequency-setting voltage
	Has the running mode been set up correctly?	Put in the correct setup
The motor rotates in opposite direction	Is the wiring of terminals U, V and W correct?	Wire them to the lead wires U, V and W of the motor in accordance with the phase sequence
	Is the input signal connection right for the forward/backward rotation?	Change the wiring
The motor rotates, but is incapable of speed changing.	Is the wiring of the frequency reference circuit correct?	Change the wiring
	Has the operation mode been correctly set up?	Check the selected running mode with an operator
	Is the load too much?	Reduce load
The rotation speed (rpm/min) of the motor is too high or too low.	Are the rated values (number of poles, voltage) right?	Check the technical data on the nameplate of the motor
	Is the acceleration/deceleration gear shifting ratio of the gear wheel right?	Checking the shifting gears (like the gear wheel and so on)
	Has the maximum output frequency been correctly set up?	Check the set value of the maximum output frequency
	Check the voltage between the terminals of the motor with a rectifier-type voltmeter. Is there too much voltage drop?	Check the V/F characteristic value
The rotation speed of the running motor is unsteady	Is the load too much?	Reduce load
	Is the change of load too much?	Reduce load change, increase the motor capacity of the frequency inverter
	What about the power supply. Is it a 3-phase or a single-phase one? If it is a 3-phase one, is there any phase loss?	Check the wiring of the 3-phase power supply for possible phase loss.

Appendix 1 Regular Maintenance and Inspection Methods

Inspection location	Items for inspection	Description	Period			Inspection method	Criteria	Measuring instrument
			Daily	Yearly	Biennial			
Exterior	Surroundings	Is there any dust? Are the ambient temperature and humidity appropriate?	√			See the precautions	Temperature: -10~+40°C; no dust; humidity: below 90% and no dew formation	Thermometer, hygrometer and a recorder
	Equipment	Is there any abnormal vibration or noise?	√			Look, see	No abnormality	
	Input voltage	Is the input voltage of the main circuit normal?	√			Measure the voltage between the terminals R, S and T		Digital AVO meter/ tester
Main Circuit	The entire operating site	Megger examination (of the resistance between the main circuit and earth) for any loosened parts. Overheat on any parts? Clean?		√		Disconnect the frequency inverter, Short-circuit the terminals R,S,T,U,V,W and measure the resistance between them and the earth. Tighten the bolts Check with naked eyes	Over 5 MΩ and fault free	DC 500V-type megger
	Conductor wiring	Conductor rusty? Wire sheath damaged?		√		Check with naked eyes	No fault	
	Terminals	Any damage?		√		Check with naked eyes	No Fault	
	IGBT module / diode	Check the impedance between terminals			√	Disconnect the frequency inverter, and measure with a tester the resistance between the group of R, S, T<-> +, - and the group of U, V, W <-> +, - respectively		Digital AVO meter / analog measuring meter
	Insulation resistance	Megohmmeter inspection (between output terminal and grounding terminal)			√	Release connection of U, V and W and fasten motor wire	Exceed 5MΩ	500V type megohmmeter

Appendix 1 Regular Maintenance and Inspection Methods

Inspecti on location	Items for inspection	Description	Period			Inspection method	Criteria	Measuring instrument
			Daily	Yearly	Biennial			
Main Circuit	Filter capacitor	Is there any liquid seepage? Is the safety hole bulging out? Is the capacitor bulging out?	√	√		Check with naked eyes Measure with capacitance meters	No fault exceeds 85% of the rated capacity	Devices for measuring capacitance
	Relay	Any wobbling noise during operation? Any damage to the contacts?		√		Listen Check with naked eyes.	No fault	
	Resistance	Whether resistance insulation is damaged Whether resistor wire is damaged (open circuit)		√		Visual inspection Disconnect one and measure it with test instrument.	There is no fault Error must be within $\pm 10\%$ of resistance value	Digital multimeter/simulation test instrument
Protecti on circuit and control circuit	Operation check	Is the output voltage balanced for all the phases? After executing sequential protection, there should be no fault in the display circuit		√		Measure the voltage among terminals U, V and W Short circuit and open frequency inverter protection circuit output	For 200V(400) model, the difference in the voltage of each phase should not exceed 4V(8V)	Digital AVO meter/ calibrating voltmeter
Cooling system	Cooling fan	Any abnormal vibration or noise? Any loosened connections?	√	√		Turn the tightening connection of the fan after switching off the power supply	Rotation smooth and no fault	
Display	Meter	Is the displayed value correct?	√	√		Check the reading of the meter outside the panel	Check the set values	Voltmeter/ ammeter
Motor	The entire operating site	Any abnormal vibration or noise? Any abnormal smells?	√			Check with your ears, nose, and eyes; Check for overheat or damage	No fault	

Note: the values in brackets apply to 400V-type frequency inverters.

## Appendix 2 Guideline for Option of Optional parts

Users of this series product can choose to install additional peripherals in accordance with the operating conditions and needs.

### A2.1 Alternative Current Reactor (ACL)

Alternative current reactor can be used to suppress the high-order harmonic of the input current from the frequency inverter, thus improve its power factors. It is recommended for the following situations:

- 1 The ratio of the capacity of the power source to that of the frequency inverter exceeds 10:1.
- 2 Silicon controlled load or power factor compensation devices with switch control is wired to the same power supply.
- 3 The 3-phase power has a high degree of voltage unbalance. ( $\geq 3\%$ )

**Table of Matching Alternating Current Reactors:**

S2/T2 Series					
Power (kW)	Current (A)	Inductance (mH)	Power (kW)	Current (A)	Inductance (mH)
0.4	2.0	4.6	2.2	10	1.0
0.75	4.0	2.4	3.7	16	0.6
1.5	7.0	1.6			

T4 Series					
Power (kW)	Current (A)	Inductance (mH)	Power (kW)	Current (A)	Inductance (mH)
0.75	2.3	7.6	93	176	0.11
1.5	3.7	4.8	110	210	0.09
2.2	5.0	3.2	132	253	0.08
3.7	8.8	2.0	160	300	0.06
5.5	13	1.5	185	340	0.06
7.5	17	1.2	200	380	0.05
11	25	0.8	220	420	0.05
15	32	0.6	250	480	0.04
18.5	37	0.5	280	540	0.04
22	45	0.42	315	600	0.03
30	60	0.32	355	680	0.03
37	75	0.26	375	710	0.03
45	90	0.21	400	750	0.03
55	110	0.18	500	930	0.02
75	152	0.13	630	1200	0.02

T6 Series					
Power (kW)	Current (A)	Inductance (mH)	Power (kW)	Current (A)	Inductance (mH)
22	28	0.47	55	68	0.23
30	38	0.35	75	92	0.18
37	46	0.28	93	110	0.15
45	56	0.28	110	132	0.12
132	155	0.094	315	345	0.042
160	180	0.07	355	390	0.036
185	210	0.07	400	430	0.028
220	245	0.055	500	540	0.023
250	275	0.048	600	630	0.021
280	305	0.042	700	720	0.019

### A2.2 DC reactor

When the capacity of the power grid far exceeds that of the frequency inverter or when the power capacity is beyond 1000KVA, or when the user expects greatly improved power factor of the power supply, direct current reactors will be necessary. Direct current reactors can be used simultaneously with alternating current reactors, which is effective in reducing higher-order harmonic input.

Table of Matching Direct Current Reactors:

T4 Series					
Power KW	Current A	$\mu$ H Inductance $\mu$ H	Power KW	Current A	Inductance $\mu$ H
18.5~30	75	600	110~132	280	140
37~55	150	300	160~185	370	110
75~90	220	200			
T6 系列					
22~55	75	600	75~110	150	300

### A2.3 Radio noise filter

Radio noise filters are used to restrain the transmission of electromagnetic interfering noises generated by the frequency inverter. They can also be used to restrain interference with the motor from external radio, instantaneous impact and surges.

Table of matching 3-phase 3-wire Radio Noise Filters:

Voltage (V)	Motor power (kW)	Voltage (V)	Motor power (kW)	Filter model	Key filter parameters					
					Common-mode input loss dB			Derivation-mode input loss dB		
					0.1MHz	1MHz	30MHz	0.1MHz	1MHz	30MHz
220	0.4~0.75	380	0.75~1.5	DL-5EBT1	75	85	55	55	80	60
	1.5~2.2		2.2~3.7	DL-10EBT1	70	85	55	45	80	60
	3.7		5.5~7.5	DL-20EBT1	70	85	55	45	80	60
	5.5~7.5		11~15	DL-35EBT1	70	85	50	40	80	60
	11		18.5~22	DL-50EBT1	65	85	50	40	80	50
	15~18.5		30~37	DL-80EBT1	50	75	45	60	80	50
	22		45	DL-100EBK1	50	70	50	60	80	50
	30		55~75	DL-150EBK1	50	70	50	60	70	50
	0.4~0.75		93~110	DL-150EBK1	50	70	60	60	70	50

In situations requiring stronger anti-radio interference capability or conformity to CE, UL, or CSA standards, or when there are devices with poor anti-interference capabilities in the vicinity, filters should be installed. While installing, make sure the wiring is as short as possible, that is, the filter should be as close to the frequency inverter as possible.

### A2.4 Remote Operation Keyboard

Our series frequency inverters have all been equipped with operation keyboards, exquisitely designed and easily operated. If you wish to use it away from the frequency inverter or other places, an extended cable would serve the purpose. You just need to demand it when you place an order. Since the serial communication mode is employed to link the keyboard and the frame, you can remove the keyboard to work area as far as 10 meters away. Or if you want to or need to work farther away, then you can buy a remote operation keyboard from the suppliers concerned, or from our company.

## A2.5 Energy Consumption Brake Unit and Brake Resistance

All E100 Series and E102 Series frequency inverters are equipped with built-in brake unit, if the brake torque is required to be increased, it is to directly connect the brake resistance. CDI-E180 Series frequency inverters with power 15kW and below are equipped with built-in brake unit. The types with power 18.5~30kW are not equipped with built-in brake unit, if the brake torque is required to be increased, it is required to externally connect brake resistance. The built-in brake unit is not equipped on the inverters above 30 Kw, if the brake torque is required to be increased, it is required to externally connect brake unit and brake resistance.

### **The formula for simple calculation for brake unit and brake resistance is as below:**

Generally, the brake current is  $1/2 I$  of the rated current of the motor, the generated brake torque is approximately equal to the rate torque of the motor. Therefore, proper brake current  $I_B$  shall be selected based on requirements of load inertia and shutdown time. The greater the load inertia is, the shorter the shutdown time requires and the greater the selected brake current  $I_B$  is.

$$I_B = (1/2 \sim 3/2) * I$$

According to brake current, the value of resistance to brake unit and brake resistance can be selected.

The peak current of the brake unit (only aim at brake unit of Delixi) is larger than  $I_B$ .

Size of Brake Resistance Value

$$R_B = U / I_B \text{ (in S2 and T2 Series, U takes 400V; in T4 Series, U takes 800V)}$$

Size of Brake Resistance Power

$$P_B = K * U * U / R_B$$

In formula,  $K$  indicates braking coefficient with range of 0.1~0.5, and the braking coefficient shall be selected based on requirements of load inertia and shutdown time. The greater the load inertia is, the shorter the shutdown time requires and the greater the selected braking coefficient  $K$  is. General load can select 0.1~0.2 and the large load inertia selects 0.5.

The following sizing table is available when  $I_D$  is approximately equal to  $1/2 I$  and  $K$  is between 0.1~0.2. The greater the load inertia is, the shorter the shutdown time requires, and proper adjustment shall be made according to the formula above.

## 1. E100 、E102 Series

Type of Frequency inverter	Type of Brake Unit	Brake Resistance Value (Ω)	Brake Resistance Power (W)
<b>S2 (Single Phase 220V)</b>			
CDI-E100G0R4S2B	Built-in, allowable Max. Current 8A	400	80
CDI-E100G0R7S2B	Built-in, allowable Max. Current 8A	200	160
CDI-E100G1R5S2B	Built-in, allowable Max. Current 15A	120	250
CDI-E100G2R2S2B	Built-in, allowable Max. Current 15A	80	400
<b>T2 (Three-phase 220V)</b>			
CDI-E100G0R4T2B	Built-in, allowable Max. Current 8A	400	80
CDI-E100G0R7T2B	Built-in, allowable Max. Current 8A	200	160
CDI-E100G1R5T2B	Built-in, allowable Max. Current 15A	120	250
CDI-E100G2R2T2B	Built-in, allowable Max. Current 25A	80	400
<b>T4 (Three-phase 380V)</b>			
CDI-E100G0R7T4B	Built-in, allowable Max. Current 8A	600	160
CDI-E100G1R5T4B	Built-in, allowable Max. Current 8A	400	250
CDI-E100G2R2T4B	Built-in, allowable Max. Current 15A	250	400
CDI-E100G3R7T4B	Built-in, allowable Max. Current 15A	150	600
CDI-E100G5R5/P7R5T4B	Built-in, allowable Max. Current 40A	100	1000
CDI-E100G7R5/P011T4B	Built-in, allowable Max. Current 40A	75	1200
CDI-E100G011/P015T4BL	Built-in, allowable Max. Current 50A	50	2000
CDI-E100G015/P018.5T4BL	Built-in, allowable Max. Current 75A	40	2500
CDI-E100G018.5/P022T4	Built-in, allowable Max. Current 75A	30	4000
CDI-E100G022/P030T4	Built-in, allowable Max. Current 75A	30	4000
CDI-E100G030/P037T4	Built-in, allowable Max. Current 75A	20	6000
CDI-E100G037/P045T4	Built-in, allowable Max. Current 75A	16	9000
CDI-E100G045/P055T4	Built-in, allowable Max. Current 100A	13.6	9000
CDI-E100G055/P075T4	Built-in, allowable Max. Current 100A	20/2	12000
CDI-E100G075/P093T4	Built-in, allowable Max. Current 200A	13.6/2	18000
CDI-E100G093/P110T4	Built-in, allowable Max. Current 200A	20/3	18000
CDI-E100G110/P132T4	Built-in, allowable Max. Current 200A	20/3	18000
CDI-E100G132/P160T4	CDI-BR-200	20/4	24000
CDI-E100G160/P185T4	CDI-BR-400	13.6/4	36000
CDI-E100G185/P200T4	CDI-BR-400	13.6/5	45000
CDI-E100G200/P220T4L	CDI-BR-400	13.6/5	45000
CDI-E100G220T4L	CDI-BR-400	13.6/6	54000
CDI-E100P250T4L	CDI-BR-400	13.6/6	54000

Appendix 2 Guideline for Option of Optional parts

Type of Frequency inverter	Type of Brake Unit	Brake Resistance Value (Ω)	Brake Resistance Power (W)
CDI-E100G250/P280T4L	CDI-BR-400	13.6/6	54000
CDI-E100G280/P315T4L	CDI-BR-400	13.6/6	54000
CDI-E100G315/P355T4L	CDI-BR-400	13.6/6	54000
CDI-E100G355/P375T4L	CDI-BR-600	13.6/7	63000
CDI-E100G375T4L	CDI-BR-600	13.6/7	63000
CDI-E100P400T4L	CDI-BR-600	13.6/8	72000
CDI-E100G400T4L	CDI-BR-600	13.6/8	72000
CDI-E100P500T4L	CDI-BR-600	13.6/9	81000
CDI-E100G500T4L	CDI-BR-600	13.6/9	81000
CDI-E100G630T4L	2*CDI-BR-400	13.6/10	90000

**Note: The brake components of E102 series inverter types are same as those of E100 series inverter.**

**2. E180 Series**

Type of Frequency inverter	Type of Brake Unit	Brake Resistance Value (Ω)	Brake Resistance Power (W)
<b>T2 (Three-phase 220V)</b>			
CDI-E180G0R4T2B	Built-in, allowable Max. Current 10A	350	160
CDI-E180G0R75T2B	Built-in, allowable Max. Current 10A	200	160
CDI-E180G1R5T2B	Built-in, allowable Max. Current 25A	100	250
CDI-E180G2R2T2B	Built-in, allowable Max. Current 25A	75	400
CDI-E180G3R7T2B	Built-in, allowable Max. Current 40A	45	600
CDI-E180G5R5T2B	Built-in, allowable Max. Current 50A	30	1000
CDI-E180G7R5T2BL	Built-in, allowable Max. Current 75A	20	1200
CDI-E180G011T2	Built-in, allowable Max. Current 50A Externally-connect CDI-BR-50	16	2000
CDI-E180G015T2	Built-in, allowable Max. Current 75A Externally-connect CDI-BR-50	12	2500
CDI-E180G018.5T2	CDI-BR-100	20/2	4000
CDI-E180G022T2	CDI-BR-100	16/2	4000
CDI-E180G030T2	CDI-BR-100	13.6/2	6000
<b>T4 (Three-phase 380V)</b>			
CDI-E180G0R75T4B	Built-in, allowable Max. Current 10A	600	160
CDI-E180G1R5T4B	Built-in, allowable Max. Current 10A	400	250
CDI-E180G2R2T4B	Built-in, allowable Max. Current 15A	250	400
CDI-E180G3R7/P5R5T4B	Built-in, allowable Max. Current 25A	150	600
CDI-E180G5R5MT4B	Built-in, allowable Max. Current 40A	100	1000
CDI-E180G5R5/P7R5T4B	Built-in, allowable Max. Current 40A	100	1000
CDI-E180G7R5/P011T4B	Built-in, allowable Max. Current 40A	75	1200
CDI-E180G011MT4B	Built-in, allowable Max. Current 50A	50	2000
CDI-E180G011/P015T4BL	Built-in, allowable Max. Current 50A	50	2000
CDI-E180G015/P018.5T4BL	Built-in, allowable Max. Current 75A	40	2500
CDI-E180G018.5/P022T4	Built-in, allowable Max. Current 50A Externally-connect CDI-BR-50	30	4000
CDI-E180G022/P030T4	Built-in, allowable Max. Current 50A Externally-connect CDI-BR-50	30	4000
CDI-E180G030/P037T4	Built-in, allowable Max. Current 75A Externally-connect CDI-BR-50	20	6000
CDI-E180G037/P045T4	CDI-BR-100	16	9000
CDI-E180G045/P055T4	CDI-BR-100	13.6	9000
CDI-E180G055/P075T4	CDI-BR-100	20/2	12000
CDI-E180G075/P093T4	CDI-BR-200	13.6/2	18000
CDI-E180G093/P110T4	CDI-BR-200	20/3	18000
CDI-E180G110/P132T4	CDI-BR-200	20/3	18000

## Appendix 2 Guideline for Option of Optional parts

Type of Frequency inverter	Type of Brake Unit	Brake Resistance Value ( $\Omega$ )	Brake Resistance Power (W)
CDI-E180G132/P160T4	CDI-BR-200	20/4	24000
CDI-E180G160/P185T4	CDI-BR-400	13.6/4	36000
CDI-E180G185/P200T4	CDI-BR-400	13.6/5	45000
CDI-E180G200/P220T4L	CDI-BR-400	13.6/5	45000
CDI-E180G220T4L	CDI-BR-400	13.6/6	54000
CDI-E180P250T4L	CDI-BR-400	13.6/6	54000
CDI-E180G250/P280T4L	CDI-BR-400	13.6/6	54000
CDI-E180G280/P315T4L	CDI-BR-400	13.6/6	54000
CDI-E180G315/P355T4L	CDI-BR-400	13.6/6	54000
CDI-E180G355/P375T4L	CDI-BR-600	13.6/7	63000
CDI-E180G375T4L	CDI-BR-600	13.6/7	63000
CDI-E180P400T4L	CDI-BR-600	13.6/8	72000
CDI-E180G400T4L	CDI-BR-600	13.6/8	72000
CDI-E180P500T4L	CDI-BR-600	13.6/9	81000
CDI-E180G500T4L	CDI-BR-600	13.6/9	81000
CDI-E180G630T4L	2*CDI-BR-400	13.6/10	90000

Note: 13.6/2 means two resistances of 13.6 used in parallel connection;  
2\*CDI-BR-400 means two CDI-BR-400 brake units used in parallel connection, in this case, the brake resistance will be assigned to two brake units equally, otherwise the brake units will be damaged.

## Appendix 3 E180 I/O Expansion Card

### 1. Introduction

Expansion Card E180-IO is developed by Delixi (Hangzhou) Inverter Co., Ltd and is applied for CDI-E180 Series Terminal I/O. It is divided into: E180-IO1 and E180-IO2. Its specific configuration is as below:

Spec.	Function name	Description
E180-IO1	E180-IO1 Expansion Card	4-way Digital Input (DI7~DI10) 1-way Analog Input (VF3) 2-way Multi-functional Open Collector Output (YO1、YO2) RS-485 Communication Interface (SG+,SG-)
E180-IO2	E180-IO2 Expansion Card	4-way Digital Input (DI7~DI10) 1-way Analog Input (VF3) 2-way Multi-functional Open Collector Output (YO1、YO2)

### 2. Mechanical Installation

The frequency inverter shall be installed when it switched off completely.

Align IO expansion card with expansion card interface and positioning hole on the control panel of the frequency inverter and then fix them with screws.

IO  
Expansion  
Card

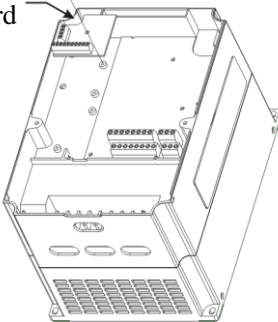

Installation Method of IO E180-IO1 Appearance Expansion Card

E180-IO2 Appearance

## 3. Description for Control Terminal

Category	Terminal	Name of Terminal	Explanation for Function
Digital Input Terminal	DI7-COM	Digital Input 7	Specific functions refer to explanation for use of Function Code P2.0.06~P2.0.09 <b>Note: Only internal power supply is applicable</b>
	DI8-COM	Digital Input 8	
	DI9-COM	Digital Input 9	
	DI10-COM	Digital Input 10	
Multi-functional Output Terminal	YO1	Multi-functional Open	Specific functions refer to explanation for use of Function Code P2.0.08~P2.0.31 Drive Capability: DC48V 50mA below
	CME	Collector Output 1	
	YO2	2 Multi-functional Open	
	CME	Collector Output 2	
Analog Input Terminal	VF3-GND	Analog Input Terminal 3	Be used for receiving external analog signal input, which is voltage signal 0V~10V or current signal 0/4mA~20mA
24V Power Supply	COM	24V Power Supply Output	Externally provide DC 24V Supply Voltage, which is generally used for digital input terminal or working power supply of external low-voltage devices. Drive Capability: Max. Output Current 300mA
	P24		
Communication Terminal	SG+	Positive Signal Terminal of RS485 Communication	Support MODBUS-RTU Protocol
	SG-	Negative Signal Terminal of RS485 Communication	

**Note: if Terminal VF3 is adopted, it is to short J9 on IO expansion card. At this moment, the function of keyboard potentiometer will be replaced by the function of Terminal VF3.**

## Appendix 4 E180 Encoder Expansion Card

### 1. Introduction

CDI-E180 Series can realize Closed-loop Vector Control against different load motor, which is required to different encoder. Accordingly, there are many various expansion cards of the encoder with specific types as below:

Type	Name	Description
E180-PG1	E180 Encoder Expansion Card 1	Support A, B, Z differential input without frequency division output Max.Speed:100kHz Differential Input Signal Amplitude: $\leq 7V$
E180-PG2	E180 Encoder Expansion Card 2	Support A, B, Z, U, V, W differential input without frequency division output Max.Speed:100kHz Differential Input Signal Amplitude: $\leq 7V$
E180-PG3	E180 Encoder Expansion Card 3	Support A, B, Z open collector input Max speed: 100kHz
E180-PG4	E180 Rotary Transformer Expansion Card 4	Support Rotary Transformer 10kHz 7VRMS excitation output 12-digit resolution Without frequency division output

### 2. Mechanical Installation

The frequency inverter shall be installed when it switched off completely.

Align expansion card with expansion card interface and positioning hole on the control panel of the frequency inverter and then fix them with screws.

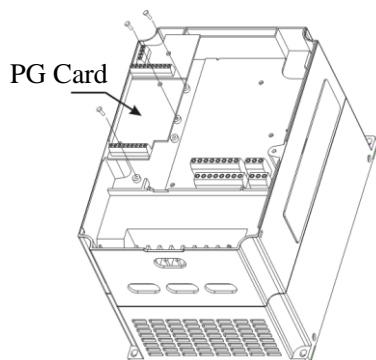

Installation method of PG Expansion Card



Appearance of E180-PG1

Appearance of E180-PG2

Appearance of E180-PG3

Appearance of E180-PG4

3. Definition Description of Connection Terminal Signal

Definition for E180-PG1 Connection Terminal Signal

Name of Terminal	Description
A+	Positive Encoder A Signal
A-	Negative Encoder A Signal
B+	Positive Encoder B Signal
B-	Negative Encoder B Signal
Z+	Positive Encoder Z Signal
Z-	Negative Encoder Z Signal
5V	Externally provide Power 5V and Max. output current is 100mA
COM	Power Ground

Definition for E180-PG2 Connection Terminal Signal

Name of Terminal	Description
A+	Positive Encoder A Signal
A-	Negative Encoder A Signal
B+	Positive Encoder B Signal
B-	Negative Encoder B Signal
Z+	Positive Encoder Z Signal
Z-	Negative Encoder Z Signal
U+	Positive Encoder U Signal
U-	Negative Encoder U Signal
V+	Positive Encoder V Signal
V-	Negative Encoder V Signal
W+	Positive Encoder W Signal
W-	Negative Encoder W Signal
5V	Externally provide Power 5V and Max. output current is 100mA
COM	Power Ground

Definition for E180-PG3 Connection Terminal Signal

Name of Terminal	Description
A	Encoder A signal
B	Encoder B signal
Z	Encoder Z signal
24V	Externally provide Power 24V and Max. output current is 100mA
COM	Power Ground

Definition for E180-PG4 Connection Terminal Signal

Name of Terminal	Description
EXC+	Rotary transformer excitation positive (+)
EXC-	Rotary transformer excitation negative (-)
SIN+	Rotary transformer feedback SIN positive (+)
SIN-	Rotary transformer feedback SIN negative (-)
COS+	Rotary transformer feedback COS positive (+)
COS-	Rotary transformer feedback COS negative (-)

## Appendix 5 Expansion Card of RS485 Communication

### 1. Introduction

For CDI-E180 Series and E102 are not configured with communication function, if communication required, the expansion card for communication needs to be added. Specific types are as below:

Type	Name	Description
E180-485	E180 Communication Expansion Card	SG+: Positive Signal Terminal of RS485 Communication SG-: Negative Signal Terminal of RS485 Communication Support MODBUS-RTU Protocol
E102-485	E102 Communication Expansion Card	SG+: Positive Signal Terminal of RS485 Communication SG-: Negative Signal Terminal of RS485 Communication Support MODBUS-RTU Protocol

### 2. Mechanical Installation

The frequency inverter shall be installed when it switched off completely.

Align RS485 Communication with expansion card interface and positioning hole on the control panel of the frequency inverter and then fix them with screws.

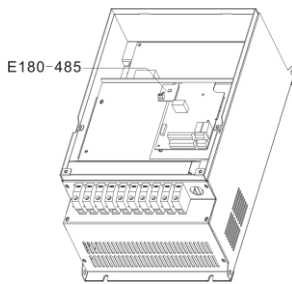

E180-485 Installation Method

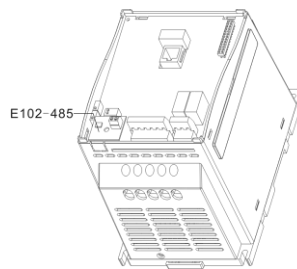

E102-485 Installation Method



Appearance of E180-485



Appearance of E102-485

## Appendix 6 Expansion Card of E180 Injection Molding Machine

### 1. Introduction

E180-ZS Expansion Card is developed by Delixi (Hangzhou) Inverter Co., Ltd and applied for CDI-E180 Series Terminal ZS, its specific configuration is as below:

Type	Name	Description
E180-ZS	E180 Expansion Card of Injection Molding Machine	2-way Digital Input Terminal (DI7~DI8) Refer to Description for use of specific functions of Function Code P2.0.06~P2.0.07 <b>Note: Only internal power supply is applicable</b>
		2-way Analog Input Terminal (G1-S1, G2-S2) G1:Connect proportional flow signal negative S1:Connect proportional flow signal positive G2:Connect proportional voltage signal negative S2:Connect proportional voltage signal positive <b>Note: proportional flow and proportional voltage signal are DC Current Signal 0~1A, and corrective wiring shall be made according to the flow of circuit current</b>

### 2. Mechanical Installation

The frequency inverter shall be installed when it switched off completely.

Align Expansion Card E180-ZS with expansion card interface and positioning hole on the control panel of the frequency inverter and then fix them with screws.

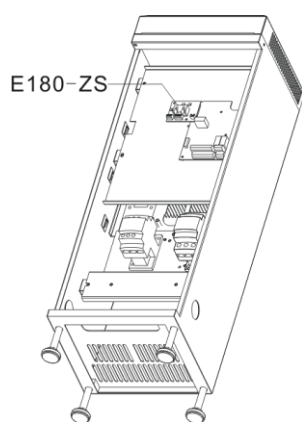

E180-ZS Installation Method

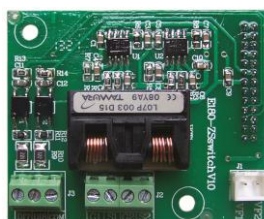

Appearance of E180-ZS

## Appendix 7 E180-DP Expansion Card

### 1. Introduction

E180-DP Expansion Card is developed by Delixi (Hangzhou) Inverter Co., Ltd. and used for E180 Series inverters and realizing PROFIBUS communication to PROFIBUS-DP master station.

**Description: The E180-DP card is only supported by the E180 series inverter with the model number including DP and the power above 3.7kW, the user shall pay special attention to the requirement. For example: CDI-E180G3R7/P5R5T4B(DP).**

### 2. Installation

Please cut off power supply of inverter before installation of E180-DP expansion card, so as to ensure the installation can be conducted only when LED indicator of power charging of inverter is black out completely. See the below figure for detailed installation method. Please fasten the relevant screws after the E180-DP is inserted into inverter.

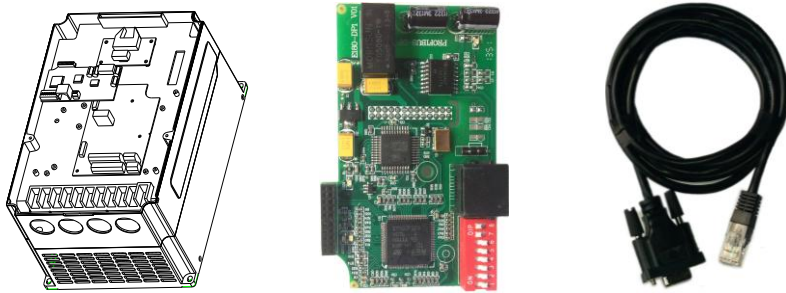

Installation schematic diagram of E180-DP      Appearance of E180-DP card      of Outer cable of E180-DP card

### 3. Parameter setting of inverter

Function Code	Name	Setting range	Description
P4.1.00	Baud rate of inverter	Tens: control PROFIBUS communication 0: 115200 1: 208300 2: 256000 3: 512000	When PROFIBUS communication is adopted, you can select baud rate same as inverter through the 1 <sup>st</sup> and 2 <sup>nd</sup> digit of DIP switch of E180-DP.
P4.1.02	Local IP address	1-126	
P4.1.05	Data transmission format	Tens: control PROFIBUS communication 0: PPO1 1: PP02 2: PP03 3: PP05	The data format shall be same as the format selected by PROFIBUS master station

4. Definition and description of connection terminal signal

DIP No.	Function	Description		
1 , 2	E180-DP card and inverter communication baud rate selection	The 1 <sup>st</sup> digit	The 2 <sup>nd</sup> digit	Baud rate
		OFF	OFF	115200
		OFF	ON	208300
		ON	OFF	256000
ON	ON	512000		
3~8	Address of E180-DP communication slave station	Total 64 addresses are comprised of 6-digit binary system, and for the addresses over 64 can be set up through function code. The examples of DIP switch setting and corresponding address are as follows: Setting of DIP switch    Address 000001                    1 011110                    30		
Wire jumper No.	Description of function			
J1	Selection of matched resistor for PROFIBUS terminal			

5. Description of 9-pin standard interface of outer cable

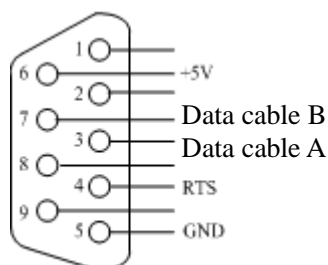

Syboмл	Name of terminal	Function description
3	Data cable B	Positive pole (+) of data cable
4	RTS	Request transferring signal
5	GND	Insulation 5V power supply grounding
6	+5V	Insulation 5V power supply
8	Data cable A	Negative pole (-) of data cable

6. LED indicator

LED indicator	Name	Description
LED1 (red)	LED indicator for power supply	The indicator shall be constant ON, after E180-DP card connects to inverter properly and inverter is electrified.
LED2 (green)	LED indicator for communication established between PROFIBUS master station and E180-DP card	After E180-DP card connects to inverter properly, the indicator shall be constant ON, if flicker, means improper connection (on-again & off-again), if black-out, means failure connection to PROFIBUS station (check slave station address, data format and programming cable).
LED3 (yellow)	LED indicator for communication established between inverter and E180-DP card	After E180-DP card connects to inverter properly, the indicator shall be constant ON, if flicker, means improper connection (on-again & off-again), if black-out, means failure connection to inverter (check baud rate).

6. Description and solution to failure

LED1 (red)	LED2 (green)	LED3 (yellow)	Description of failure	Corresponding solution
Black	Black	Black	No power supply on E180-DP card	Check whether the interface with inverter is connected properly?
Bright	Black	Black	No communication is established to PROFIBUS master station	Check whether the setup of PROFIBUS master station, address of slave station and data format are correct; check whether the connection of PROFIBUS cable is OK?
Bright	Bright	Black	No communication established to inverter	Check whether the baud rate of inverter is same as E180-DP DIP switch?
Bright	Bright	Bright	Communication established	

## Appendix 8 E180-WSP Expansion Card

### 1. Main features

1. The E180-WSP Expansion Card for constant pressure water supply is able to realize automatic control of 4 main pumps + 1 sub-pump.
2. The keyboard (E180 general type) is used for function parameters setting with 5-digit digital tube display for convenient operation and commission.
3. The active pumps can be set as adjustable pump and non-adjustable pump (standby adjustable pump and standby non-adjustable pump) through function parameters setting, and the pumps can be arranged on demands to satisfy various complicated water supply system or fire protection system.
4. The function of timed pump-changing function is added in order to balance working time among each pump and extend average lifetime of water pump.
5. Fire-protection pump polling function can carry out polling for the fire-protection pump under the mode of fire protection according to the set time, so as to prevent corrosion of fire-protection pump.
6. Total 8 time intervals pressure control are available in the product, and pressure value and timing ON/OFF setting function can be done within each time interval as desired.
7. The function of dormancy and sub-pump is able to realize energy-saving and extend the lifetime of machine.
8. Add function of second-target pressure and setting via external terminal input.
9. The function of Automatic Transfer Switching is equipped, i.e. the standby pump can automatically work while main pump has failure.
10. PI adjustment has function of positive and negative feedback selection, which can be used for both water supply and water pumping for water level maintaining.
11. Provide alarm function for over-pressure, lose-control pressure and inverter failure etc.
12. Once the inverter has failure, it is possible to select “shift to working frequency operation automatically (pressure section control)”
13. Be equipped with function of automatic failure reset with adjustable delay.
14. Be able to record 5 records of latest failure type and time in max.

### 2. Installation

Please cut off power supply of inverter before installation of E180-WSP expansion card, so as to ensure the installation can be conducted only when LED indicator of power charging of inverter is black out completely. See the below figure for detailed installation method. Please fasten the relevant screws after the E180-WSP is inserted into inverter. **(Note: only the models 5.5 kW and above support E180-WSP card)**

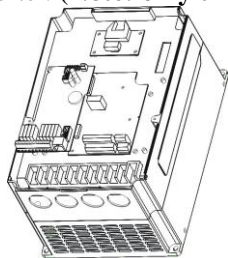

Installation method



Appearance of E180-WSP card

⊗	⊗	⊗	⊗	⊗	⊗	⊗	⊗	⊗	⊗
CM1	B1	D1	B2	D2	B3	D3	B4	D4	XB

Connection terminal of E180-WSP expansion card

Name	Description
CM1	Public terminal of pump output relay
B1	Variable frequency pump control point of pump No. 1
D1	Working frequency pump control point of pump No. 1
B2	Variable frequency pump control point of pump No. 2
D2	Working frequency pump control point of pump No. 2
B3	Variable frequency pump control point of pump No. 3
D3	Working frequency pump control point of pump No. 3
B4	Variable frequency pump control point of pump No. 4
D4	Working frequency pump control point of pump No. 4
XB	Control point of sub-pump (water supply pump)