

Micrometer

The origin of Mitutoyo's trustworthy brand of small tool instruments

High-Accuracy Digimatic Micrometer SERIES 293

MeasurLink® ENABLED
Data Management Software by Mitutoyo

- Enabling 0.1 μm resolution measurement, this micrometer is ideal for customers who need to make highly accurate measurements with a hand-held tool.
- The High-Accuracy Digimatic Micrometer utilizes Mitutoyo's innovative 0.1 μm resolution ABS (absolute) rotary sensor*1 and high-accuracy screw machining technology to reduce the Maximum permissible error to ±0.5 μm, delivering higher accuracy without sacrificing operability.
*1 Patent pending in Japan, the United States of America, the European Union, and China.
- A highly rigid frame and high-performance constant-force mechanism*2 enable more stable measurement, while the clicks emitted while the workpiece is being measured assure the operator that measurement is proceeding normally.
*2 Patent pending in Japan, the United States of America, the European Union, and China.
- Body heat transferred to the instrument is reduced by a (removable) heat shield, minimizing the error caused by thermal expansion of the frame when performing handheld measurements.

- The ABS (absolute) rotary sensor also eliminates the need to perform origin setting each time the power is turned on, letting you start measuring straight away. With no possibility of overspeed errors, the High-Accuracy Digimatic Micrometer also delivers a higher level of reliability.
- The High-Accuracy Digimatic Micrometer has a range of features to enable flexible measurement including switchable resolution (0.0001 mm/0.0005 mm), function lock and preset.
- Carbide-tipped measuring faces

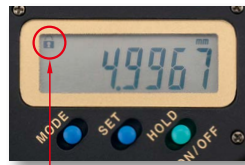

Function lock



293-100-10

MeasurLink® ENABLED
Data Management Software by Mitutoyo

Products equipped with the measurement data output function can be connected to the measurement data network system MeasurLink® (refer to page A-25 for details).



An inspection certificate is supplied as standard. Refer to page U-9 for details.

ABSOLUTE™

Functions

Preset (ABS measurement system):

The measurement origin can be preset to any value within the display range for convenience in measuring.

Zero-setting (INC measurement system):

The display can be zeroed at any position of the spindle, making comparison measurement easier. Returning to the absolute-measurement mode is easily accomplished.

Hold:

The displayed value is held while the spindle is withdrawn and the micrometer moved so that the display can be read at the operator's convenience. After cancelling the hold, the instrument returns to the previous measuring mode (absolute or incremental).

Resolution switching:

The resolution of the display can be switched. If 0.1 μm measurement is not required, the resolution can be switched to 0.5 μm.

Function lock:

Functions such as preset or zero-set can be locked to avoid inadvertently changing the origin position.

On / off:

The power can be turned off after measurement is complete. Even after the power is turned off, the origin or last zero-set position remains in the memory.

Auto power off:

Even if the power is left on, the power turns off automatically if the micrometer is not used within a 20-minute period.

Measurement data output:

Measurement data can be output, allowing easy incorporation of this instrument into a statistical process control or measurement system.

Error alarm:

In the unlikely event of a display overflow or calculation error, an error message is displayed and measurement stops. Measurement cannot continue until the error is corrected.

Also, if the battery voltage drops below a certain point, the battery indicator will turn on before measurement becomes impossible, warning the user that the battery needs to be replaced.

Micrometer

The origin of Mitutoyo's trustworthy brand of small tool instruments

QuantuMike SERIES 293 — IP65 Micrometer with 2 mm/rev Spindle Feed

- Advanced pioneering technology has created the next generation of micrometer, the most revolutionary advance in micrometer technology since James Watt invented the instrument.
- Faster measurement is achieved by using a coarser thread which feeds the spindle by 2 mm per revolution of the thimble. This increase in thread lead has been made possible thanks to new high precision thread-cutting and testing techniques.

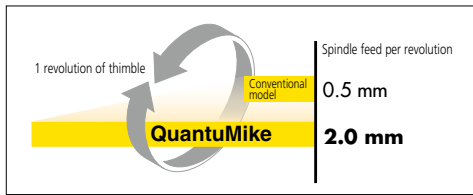

- QuantuMike is equipped with a function lock feature to prevent the origin point being moved by mistake during measurement.

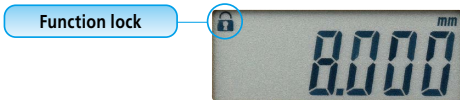

- A graduated scale is provided on the sleeve for use with a reference mark on the thimble so that every millimeter displacement can be checked to provide extra confidence.

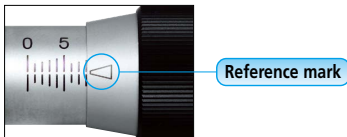

- A statistical process control system and a measurement network system can be established to share information regarding quality with a model equipped with the data output function. (Refer to page A-3 for details.)
- There is a lineup of convenient Interface Input Tools which enable the conversion of measurement data to keyboard signals and directly input them to cells in off-the-shelf spreadsheet software such as Excel. (Refer to page A-5 for details.)
- Excellent resistance against oil, water and dust (IP65 protection level) enables this product to be used in machining situations that include splashing coolant fluid.
- Measuring faces: Carbide.



Ratchet-induced microvibrations along the spindle help ensure repeatable measurements.

MeasurLink[®] ENABLED
Data Management Software by Mitutoyo



293-140-30



293-142-30



293-143-30

- The name QuantuMike is from Quantum and Micrometer, reflecting our belief this tool represents a quantum leap in micrometer ergonomics.



MeasurLink[®] ENABLED
Data Management Software by Mitutoyo

Products equipped with the measurement data output function can be connected to the measurement data network system MeasurLink[®] (refer to page A-25 for details).

IP65

These marks indicate that a product has successfully passed IP65-level testing, which is carried out by the independent German certification organization TÜV Rheinland.

TÜVRheinland
CERTIFIED

Dust- and
Water-
Protected

www.tuv.com
ID 000040191

PROPRIETARY
INSPECTION
CERTIFICATE

An inspection certificate is supplied as standard. Refer to page U-9 for details. (Maximum measuring range up to 50 mm)

IP Codes

Level 6: Dust-proof.

No ingress of dust allowed.

Level 5: Protected against water jets.

Water projected in jets against the enclosure from any direction shall have no harmful effects.

Technical Data

- Dust/Water protection level: IP65 (IEC60529)*1
- Measuring force: 7 to 12 N*2
- Battery: SR44 (1 pc.), **938882**, for initial operational checks (standard accessory)
- Battery life: Approx. 2.4 years under normal use
- Length standard: Electromagnetic rotary sensor
- Standard accessories: Reference bar, 1 pc. (except for 0 to 25 mm (0 to 1 in) models) Spanner (**301336**), 1 pc.

*1 Rustproofing shall be applied after use.

*2 Measuring force when using the speeder ratchet (Apply a measuring force in the same condition as for measurement and then set the origin.)

Functions

Origin point setting (ABS length measurement system):

Pressing the ORIGIN button resets the ABS origin at the current spindle position. Origin values can be set depending on each size.

Zero setting (INC length measurement system):

A brief press on the ZERO/ABS button sets display to zero at the current spindle position and switches to the incremental (INC) measuring mode. A longer press resets to the ABS measuring mode.

Hold:

Pressing the HOLD button freezes the current value in the display. This function is useful for preserving a measurement in situations of poor visibility when the instrument must be moved away from the workpiece before the reading can be recorded.

Function lock:

This function allows the ORIGIN (origin point setting) function and the ZERO (zero setting) function to be locked to prevent these points being reset accidentally.

Auto power ON/OFF:

The reading on the LCD disappears after this instrument is idle for approx. 20 minutes, but the origin point is retained. Turning the spindle causes the reading on the LCD to reappear.

Data output*3:

Models equipped with this function have an output port for transferring measurement data to a Statistical Process Control (SPC) system.

Error alarm:

In case of an overflow on the LCD or a computing error, an error message appears on the LCD, and the measuring function stops. This prevents an instrument from giving an erroneous reading. Also, when the battery voltage drops to a certain level, the low-battery-voltage alarm annunciator appears well before the micrometer becomes unusable.

*3 Only for the models with SPC data output

Optional Accessories

(Only for models with data output function)

- Connecting cables with output switch
1 m: **05CZA662** 2 m: **05CZA663**
- USB Input Tool Direct
USB-ITN-B (2 m): **06AFM380B**
- **U-WAVE-T** dedicated connection cable
160 mm: **02AZD790B**
For foot switch: **02AZE140B**

Wireless Data Output U-WAVE™

- **U-WAVE-TM 264-622** (IP67 type) **264-623** (Buzzer type)
 - **U-WAVE-TMB** Transmitter
Mitutoyo Bluetooth® U-WAVE 264-626 (IP67 type)
264-627 (Buzzer type)
- Refer to page A-10 for details.
- Connecting unit for **U-WAVE-TM/TMB**
02AZF310 (IP67/buzzer type common specification)
Refer to pages A-10 and A-12 for details.



SPECIFICATIONS

		Metric					
	Order No.	Range (mm)	Resolution (mm)	Maximum permissible error J_{MPE} (μm)	Flatness (μm)	Parallelism (μm)	Mass (g)
with SPC data output	293-140-30	0 - 25	0.001	±1	0.3	1	265
	293-141-30	25 - 50					325
	293-142-30	50 - 75		±2		2	465
	293-143-30	75 - 100					620
without SPC data output	293-145-30	0 - 25	0.001	±1	0.3	1	265
	293-146-30	25 - 50					325
	293-147-30	50 - 75		±2		2	465
	293-148-30	75 - 100					620

		Inch/Metric					
	Order No.	Range (in)	Resolution	Maximum permissible error J_{MPE} (in)	Flatness (in)	Parallelism (in)	Mass (g)
with SPC data output	293-180-30	0 - 1	0.00005 in/ 0.001 mm	±0.00005	0.000012	0.00004	265
	293-181-30	1 - 2					325
	293-182-30	2 - 3		±0.0001		0.00008	465
	293-183-30	3 - 4					620
without SPC data output	293-185-30	0 - 1	0.00005 in/ 0.001 mm	±0.00005	0.000012	0.00004	265
	293-186-30	1 - 2					325
	293-187-30	2 - 3		±0.0001		0.00008	465
	293-188-30	3 - 4					620

DIMENSIONS

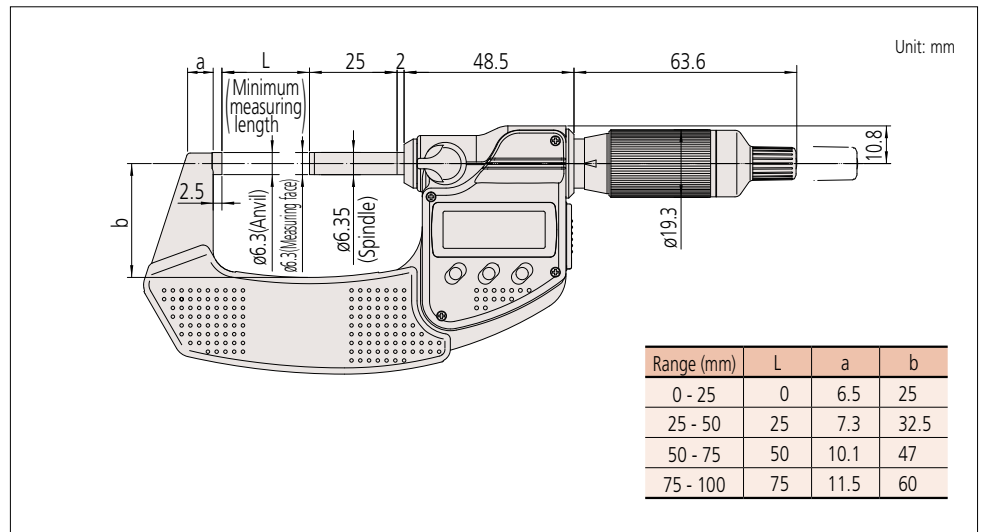

Measuring time on a 6-stepped workpiece with one hand

Thanks to the quick movement, positioning times are reduced by 60%* and measuring times by 35%* compared with a conventional micrometer.

* According to Mitutoyo's comparison test data for measuring time on typical workpieces.

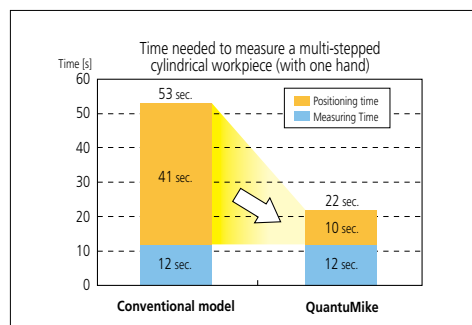

Micrometer

The origin of Mitutoyo's trustworthy brand of small tool instruments

Coolant Proof Micrometers SERIES 293 — with Dust/Water Protection Conforming to IP65 Level

MeasurLink® ENABLED
Data Management Software by Mitutoyo

- World's highest performing micrometer overall.
- Extended battery life of approximately 2.4 years.
- Ergonomic anti-slip frame cover and front panel for more comfortable hand-held measurements.
- Ratchet thimble provides better operability for one-handed operation.
- Oil-resistant material used for all plastic parts.
- Models equipped with a Digimatic output port can form part of a statistical process control or networked measurement system. (Refer to page A-3 for details.)
- Interface Input Tools are available that enable the conversion of measurement data to keyboard signals that are then directly input to cells in off-the-shelf spreadsheet software such as Excel. (Refer to page A-5 for details.)
- Two types of constant-force devices are available: Ratchet Stop and Ratchet Thimble.
- Measuring faces: Carbide.



293-230-30



293-252-30



293-234-30
With ratchet thimble

MeasurLink® ENABLED
Data Management Software by Mitutoyo

Products equipped with the measurement data output function can be connected to the measurement data network system MeasurLink® (refer to page A-25 for details).



These marks indicate that a product has successfully passed IP65-level testing, which is carried out by the independent German certification organization TÜV Rheinland.



Dust- and Water-Protected

www.tuv.com
ID 0000040191



An inspection certificate is supplied as standard. Refer to page U-9 for details. (Maximum measuring range up to 50 mm)

IP Codes

Level 6: Dust-proof.

No ingress of dust allowed.

Level 5: Protected against water jets.

Water projected in jets against the enclosure from any direction shall have no harmful effects.

Technical Data

- Flatness: 0.3 μm/0.000012 in
- Dust/water protection level: IP65 (IEC60529)*1
- Measuring force: 5 to 10 N (ratchet thimble type is 7 to 12 N.)*2
- Battery: SR44 (1 pc.), **938882**, for initial operational checks (standard accessory)
- Battery life: Approx. 2.4 years under normal use
- Length standard: Electromagnetic rotary sensor
- Standard accessories: Reference bar, 1 pc. (except for 0 to 25 mm (0 to 1 in) models)
Spanner (**301336**), 1 pc.

*1 Rustproofing shall be applied after use.

*2 Refer to page B-6 for details.

Optional Accessories

(Only for models with data output function)

- Connecting cables with output switch
1 m: **05CZA662**
2 m: **05CZA663**
- USB Input Tool Direct
USB-ITN-B (2 m): **06AFM380B**
- **U-WAVE-T** dedicated connection cable
160 mm: **02AZD790B**
For foot switch: **02AZE140B**
Refer to page A-21 for details.



Wireless Data Output **u-WAVE™**

U-WAVE-TM 264-622 (IP67 type)
264-623 (Buzzer type)

- **U-WAVE-TMB** Transmitter
Mitutoyo Bluetooth® U-WAVE
264-626 (IP67 type)
264-627 (Buzzer type)
Refer to page A-10 for details.
- Connecting unit for **U-WAVE-TM/TMB**
02AZF310 (IP67/buzzer type common specification)
Refer to pages A-10 and A-12 for details.



SPECIFICATIONS

Metric

	Order No	Range (mm)	Resolution (mm)	Maximum permissible error J_{MPE} (μm)	Parallelism (μm)	Constant-force device	Mass (g)			
with SPC data output	293-230-30	0 - 25	0.001	± 1	1	With ratchet stop	270			
	293-231-30	25 - 50					330			
	293-232-30	50 - 75		2	2		470			
	293-233-30	75 - 100					625			
	293-250-30	100 - 125		3	3		600			
	293-251-30	125 - 150					740			
	293-252-30	150 - 175		4	4		800			
	293-253-30	175 - 200					970			
	293-254-30	200 - 225		5	5		1100			
	293-255-30	225 - 250					1270			
	293-256-30	250 - 275		1	1		1370			
	293-257-30	275 - 300					1590			
	without SPC data output	293-234-30		0 - 25	0.001		± 1	1	With ratchet thimble	280
		293-235-30		25 - 50						340
293-236-30		50 - 75	2	2		480				
293-237-30		75 - 100				635				
293-240-30		0 - 25	1	1		270				
293-241-30		25 - 50				330				
293-242-30		50 - 75	2	2		470				
293-243-30		75 - 100				625				
293-244-30		0 - 25	1	1		280				
293-245-30		25 - 50				340				
293-246-30		50 - 75	2	2		480				
293-247-30		75 - 100				635				

Note: All digits of models over 125 mm (5 in) measuring range are presettable.

Inch/Metric

	Order No	Range (in)	Resolution	Maximum permissible error J_{MPE} (in)	Parallelism (in)	Constant-force device	Mass (g)			
with SPC data output	293-330-30	0 - 1	0.00005 in / 0.001 mm	± 0.00005	0.00004	With ratchet stop	270			
	293-331-30	1 - 2					330			
	293-332-30	2 - 3		0.00008	0.00008		470			
	293-333-30	3 - 4					625			
	293-350-30	4 - 5		0.00012	0.00012		600			
	293-351-30	5 - 6					740			
	293-352-30	6 - 7		0.00015	0.00015		800			
	293-353-30	7 - 8					970			
	293-354-30	8 - 9		0.00016	0.00016		1100			
	293-355-30	9 - 10					1270			
	293-356-30	10 - 11		0.0002	0.0002		1370			
	293-357-30	11 - 12					1590			
	without SPC data output	293-334-30		0 - 1	0.00005 in / 0.001 mm		± 0.00005	0.00004	With ratchet thimble	280
		293-335-30		1 - 2						275
293-336-30		1 - 2	0.00004	0.00004		335				
293-340-30		0 - 1				0.00005	0.00004	270		
293-341-30		1 - 2	0.00008	0.00008				330		
293-342-30		2 - 3				0.00008	0.00008	470		
293-343-30		3 - 4	0.00005	0.00004				625		
293-344-30		0 - 1				0.00005	0.00004	280		
293-345-30		1 - 2	0.00008	0.00008				340		
293-346-30		2 - 3				0.00008	0.00008	480		
293-347-30		3 - 4	0.00005	0.00004				635		
293-348-30		0 - 1				275				

Note: All digits of models over 125 mm (5 in) measuring range are presettable.

Functions

Origin point setting (ABS measurement system):

Resets the ABS origin at the current spindle position to the minimum value of the measuring range and switches to ABS mode.

Zero-setting:

A brief press on the ZERO/ABS button sets display to zero at the current spindle position and switches to the incremental (INC) measuring mode. A longer press resets to the ABS measuring mode.

Hold:

Pressing the HOLD button freezes the current value in the display. This function is useful for preserving a measurement in situations of poor visibility where the instrument must be moved away from the workpiece before the reading can be recorded.

Data output*:

Models equipped with this function have an output port for transferring measurement data to a Statistical Process Control (SPC) system.

* Only models with the data output function

Auto power ON/OFF:

The reading on the LCD disappears after this instrument is idle for about 20 minutes, but the reading and measurement mode are retained. Turning the spindle causes the reading to reappear.

Error alarm:

In case of an overflow on the LCD or a computing error, an error message appears on the LCD, and the measuring function stops. This prevents an instrument from giving an erroneous reading. Also, when the battery voltage drops to a certain level, the low-battery-voltage alarm annunciator appears well before the micrometer becomes unusable.

Function lock:

This function allows the ORIGIN (origin point setting) function and the ZERO (zero-setting) function to be locked to prevent these points being reset accidentally.

DIMENSIONS

Unit: mm

Range (mm)	Order No.	L	a	b	c
0 - 25	293-230-30/293-240-30	0	6.5	25	2.5
25 - 50	293-231-30/293-241-30	25	7.3	32.5	
50 - 75	293-232-30/293-242-30	50	10.1	47	
75 - 100	293-233-30/293-243-30	75	11.5	60	
0 - 25	293-234-30/293-244-30	0	6.5	25	
25 - 50	293-235-30/293-245-30	25	7.3	32.5	2.5
100 - 125	293-250-30	100	16.7	76	
125 - 150	293-251-30	125	18.8	90	
150 - 175	293-252-30	150	19.1	103	
175 - 200	293-253-30	175	18.2	115	
200 - 225	293-254-30	200	16.8	126	
225 - 250	293-255-30	225	18	139	
250 - 275	293-256-30	250	18	152	
275 - 300	293-257-30	275	16	166	

Micrometer

The origin of Mitutoyo's trustworthy brand of small tool instruments

Digimatic Outside Micrometers SERIES 293

MeasurLink[®] ENABLED
Data Management Software by Mitutoyo

- Equipped with measurement data output function, it can form part of a statistical process control system or networked measurement system.
- Constant-force device: ratchet stop

- Interface Input Tools are available that enable the conversion of measurement data to keyboard signals that are then directly input to cells in off-the-shelf spreadsheet software such as Excel. (Refer to page A-5 for details.)
- Measuring faces: Carbide.



SPECIFICATIONS

Metric				
Order No.	Range (mm)	Maximum permissible error J_{MPE} (μ m)	Flatness (μ m)	Parallelism (μ m)
293-582	300 - 325	±6	0.6	5
293-583	325 - 350			
293-584	350 - 375			
293-585	375 - 400	±7	0.6	6
293-586	400 - 425			
293-587	425 - 450			
293-588	450 - 475	±8	0.6	7
293-589	475 - 500			

Inch / Metric				
Order No.	Range (in)	Maximum permissible error J_{MPE} (in)	Flatness (in)	Parallelism (in)
293-782	12 - 13	±0.0003	0.00024	0.0002
293-783	13 - 14			
293-784	14 - 15			
293-785	15 - 16	±0.00035	0.00024	0.00024
293-786	16 - 17			
293-787	17 - 18			
293-788	18 - 19	±0.0004	0.00028	0.00028
293-789	19 - 20			

DIMENSIONS

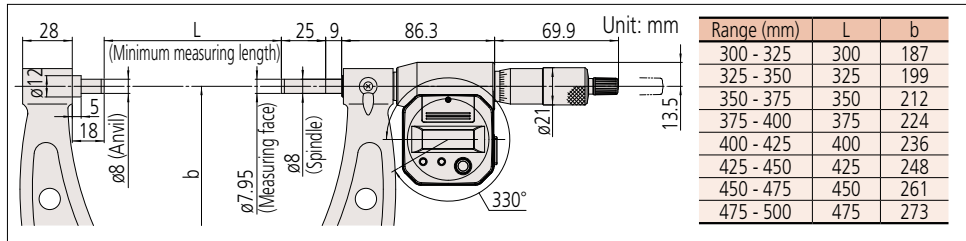

SERIES 293 — Digimatic Outside Micrometers

- Extended battery life of approximately 2.4 years.
- Simple design and excluding the data output function keeps price economical.
- One switch operation (Origin Set) for easy use.
- Equipped with Ratchet Stop for constant measuring force.
- Measuring faces: Carbide.



SPECIFICATIONS

Metric			
Order No.	Range (mm)	Resolution (mm)	Maximum permissible error J_{MPE} (μ m)
293-821-30	0 - 25	0.001	±2

Inch / Metric			
Order No.	Range (in)	Resolution	Maximum permissible error J_{MPE} (in)
293-831-30	0 - 1	0.00005 in/ 0.001 mm	±0.0001

Inch / Metric			
Order No.	Range (in)	Resolution	Maximum permissible error J_{MPE} (in)
293-832-30	0 - 1	0.00005 in/ 0.001 mm	±0.0001

DIMENSIONS

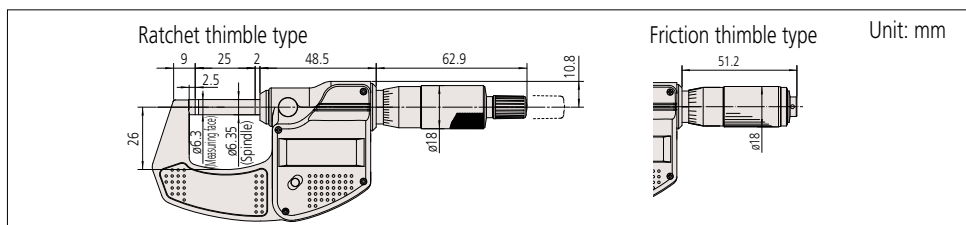

MeasurLink[®] ENABLED
Data Management Software by Mitutoyo

Products equipped with the measurement data output function can be connected to the measurement data network system MeasurLink[®] (refer to page A-25 for details).

Technical Data

- Resolution: 0.001 mm or 0.0001 in/0.001 mm
- Measuring force: 10 to 15 N
- SR44 (2 pcs.), **938882**, for initial operational checks (standard accessory)
- Battery life: Approx. 1.8 years under normal use
- Length standard: Electromagnetic rotary sensor
- Standard accessories: Reference bar, 1 pc. Spanner (**200154**), 1 pc.

Functions

Origin point setting (ABS measurement system): Resets the ABS origin at the current spindle position to the minimum value of the measuring range and switches to ABS mode.

Zero-setting (INC measurement system): A brief press on the ZERO/ABS button sets display to zero at the current spindle position and switches to the incremental (INC) measuring mode. A longer press resets to the ABS measuring mode.

Hold: Pressing the HOLD button freezes the current value in the display. This function is useful for preserving a measurement in situations of poor visibility where the instrument must be moved away from the workpiece before the reading can be recorded.

Function lock: This function allows the PRESET (origin point setting) function and the ZERO (zero-setting) function to be locked to prevent these points being reset accidentally.

Auto power ON/OFF: The reading on the LCD disappears after this instrument is idle for about 20 minutes, but the reading and measurement mode are retained. Turning the spindle causes the reading to reappear.

Data output: Models equipped with this function have an output port for transferring measurement data to a Statistical Process Control (SPC) system.

Error alarm: In case of an overflow on the LCD or a computing error, an error message appears on the LCD, and the measuring function stops. This prevents an instrument from giving an erroneous reading. Also, when the battery voltage drops to a certain level, the low-battery-voltage alarm annunciator appears well before the micrometer becomes unusable.

Optional Accessories

- Connecting Cables
 - Recommended cables:
 - L-Type (does not interfere with operating the thimble.)
 - 1 m: **04AZB512**
 - 2 m: **04AZB513**
 - Straight type (may interfere with operating the thimble.)
 - 1 m: **959149**
 - 2 m: **959150**
- Refer to page A-21 for detailed information about recommended cables.



An inspection certificate is supplied as standard. Refer to page U-9 for details.

Technical Data

- SR44 (1 pc.), **938882**, for initial operational checks (standard accessory)
- Length standard: Electromagnetic rotary sensor
- Battery life: Approx. 2.4 years under normal use
- Spanner (**301336**), 1 pc.

Functions

Zero-setting: A brief press on the ORIGIN button sets display to zero at the current spindle position (zero-setting), which allows easy comparison measurement.

Auto power ON/OFF: The reading on the LCD disappears after this instrument is idle for about 20 minutes, but the reading is retained. Turning the spindle causes the reading on the LCD to reappear.

Error alarm:

In case of an overflow on the LCD or a computing error, an error message appears on the LCD, and the measuring function stops. This prevents an instrument from giving an erroneous reading. Also, when the battery voltage drops to a certain level, the low-battery-voltage alarm annunciator appears well before the micrometer becomes unusable.

IP Codes

Level 6: Dust-proof.

No ingress of dust allowed.

Level 5: Protected against water jets.

Water projected in jets against the enclosure from any direction shall have no harmful effects.

Technical Data

- Resolution: 0.001 mm, 0.00005 in/0.001 mm
- Accuracy: Refer to the list of specifications.
- Measuring force: 5 to 12 N
- SR44 (1 pc.), **938882**, for initial operational checks (standard accessory)
- Battery life: Approx. 5 years under normal use
- Approx. 18,000 hours in continuous use
(1 year previous models **293-667/68/69/77/78/79**)
- Length standard: Electrostatic capacity absolute sensor
- Standard accessories: Reference bar, 1 pc.
(except for measuring range 0 to 30 mm (0 to 1.2 in) models)
- Maximum response speed: without limit
- The non-rotating spindle enables even inexperienced operators to perform measurements repeatably and accurately.

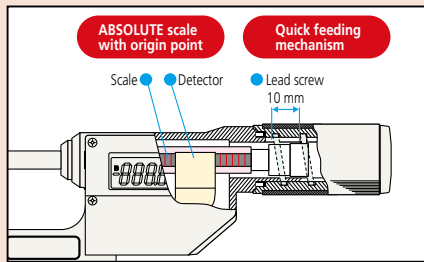

Optional Accessories

- Connecting cables
1 m: **05CZA662**
2 m: **05CZA663**
- USB Input Tool Direct
USB-ITN-B (2 m): **06AFM380B**
- Connecting cables for **U-WAVE-T**
160 mm: **02AZD790B**
For foot switch: **02AZE140B**
Refer to page A-21 for details.



Quickmike SERIES 293 — IP65 ABSOLUTE Digimatic Micrometers

- The Quickmike provides a speedy spindle feed of 10 mm per thimble rotation which enables widely differently sized features to be measured quickly.
- Set the origin only once. The absolute linear scale maintains the origin throughout the life of battery, meaning no more zero setting (presetting) or overspeed error.
- Excellent resistance against oil, water and dust (IP65 protection level) enables this product to be used in machining operations that includes splashing coolant fluid.
- Equipped with a large LCD offering easy readability.
- Pressing the HOLD button freezes the current value in the display.
- With function lock added to prevent unintended operation.
- A new low current consumption IC provides extremely long battery life.
- Measuring faces: Carbide.
- Supplied with a Ratchet Stop for constant measuring force.
- The lineup includes Blade Micrometer types (refer to page B-47), Disk Micrometer types (refer to page B-33) and Crimp Height Micrometer types (refer to page B-40).



293-666-20



293-667-20



293-668-20



293-669-20

SPECIFICATIONS

Metric							
Order No.	Range (mm)	Maximum permissible error J_{MPE} (μ m)	Flatness (μ m)	Parallelism (μ m)	Constant-force device	Mass (g)	Output function
293-666-20	0 - 30	±2	0.3	2	Yes	275	With
293-667-20	25 - 55					340	
293-668-20	50 - 80	±3	3	480			
293-669-20	75 - 105			585			

Inch / Metric							
Order No.	Range (in)	Maximum permissible error J_{MPE} (in)	Flatness (in)	Parallelism (in)	Constant-force device	Mass (g)	Output function
293-676-20	0 - 1.2	±0.0001	0.000012	0.00008	Yes	275	With
293-677-20	1 - 2.2					340	
293-678-20	2 - 3.2	±0.00015	0.00012	480			
293-679-20	3 - 4.2			585			

DIMENSIONS

