



# STAINLESS STEEL RULER KAIDAN (SATIN / POLISHED)



New stepped millimeter graduations prevents misreading



SV-150KD



SV-300KD



ST-300KD

USE

- For measuring dimensions, drawing a straight line and scribing

MATERIAL

- Stainless steel (SUS420J2)

FEATURES

- Stepped length of linear graduations by 1 mm for easy-to-read
- Sequential graduation numbers for prevention of misreading
- JIS B7516

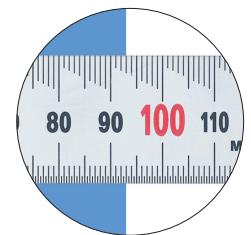
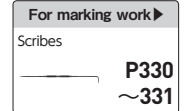
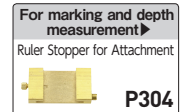

Order No.	Model No.	Nominal Size (mm)	Finish	Accuracy (mm)	Length (mm)	Width (mm)	Thickness (mm)	Weight
111287	SV-150KD	150	Satin	± 0.15	175	15	0.5	10g
111288	SV-300KD	300			335	25	1	65g
111289	SV-600KD	600		± 0.20	640	30	1.2	180g
111290	SV-1000KD	1000		± 0.25	1050	35	1.5	425g
111291	SV-1500KD	1500		± 0.30	1565	40	2	950g
111292	SV-2000KD	2000	Polished	± 0.15	2065	25	1	1250g
111281	ST-150KD	150			175	15	0.5	10g
111282	ST-300KD	300		335	25	1	65g	
111283	ST-600KD	600		± 0.20	640	30	1.2	180g
111284	ST-1000KD	1000		± 0.25	1050	35	1.5	425g
111285	ST-1500KD	1500	± 0.30	1565	40	2	950g	
111286	ST-2000KD	2000	2065	40	2	1250g		



# STAINLESS STEEL RULER KAIDAN NARROW TYPE



New stepped millimeter graduations prevents misreading



USE

- For measuring dimensions, drawing a straight line and scribing

MATERIAL

- Stainless steel (SUS420J2)

FEATURES

- Stepped length of linear graduations by 1 mm for easy-to-read
- Sequential graduation numbers for prevention of misreading
- Thin, Narrow type, can also be mounted on machine

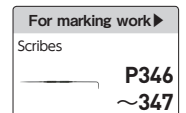
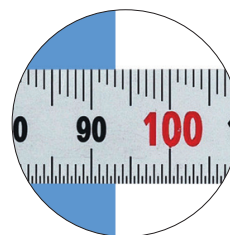

Order No.	Model No.	Nominal Size (mm)	Finish	Accuracy (mm)	Length (mm)	Width (mm)	Thickness (mm)	Weight
111295	HS-300KD	300	Satin	± 0.15	325	15	0.5	18g

Easy to pick up with on hand.  
New stepped millimeter graduations prevents misreading.

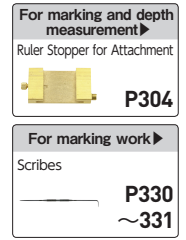
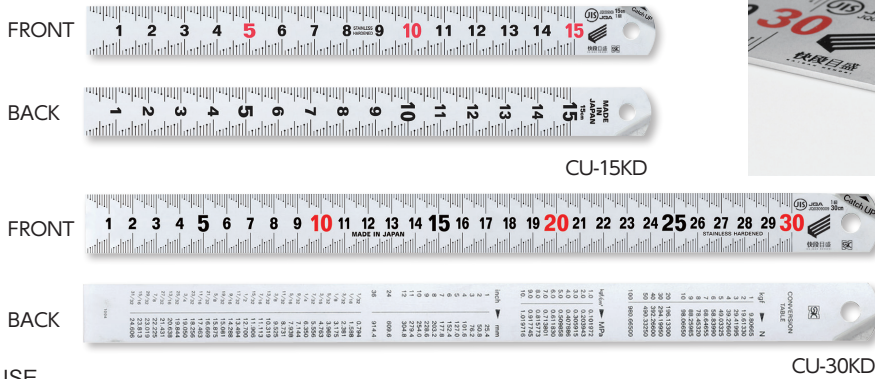

**USE**

- For measuring dimensions, drawing a straight line and scribing

**MATERIAL**

- Stainless steel (SUS420J2)

**FEATURES**

- Stepped length of linear graduations by 1mm for easy-to-read
- Sequential graduation numbers and dot marking every 2mm for prevention of misreading
- Linear graduations every 0.5mm (CU-15KDF)
- Bent-up edge for easy to pick up with one hand
- Edges are finished smoothly to prevent marring surfaces
- JIS B7516
- Satin finish

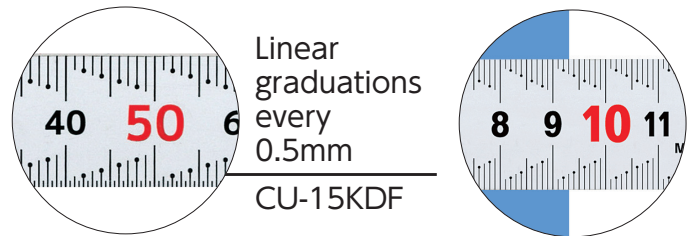

Order No.	Model No.	Nominal Size (cm)	Finish	Accuracy (mm)	Length (mm)	Width (mm)	Thickness (mm)	Weight
111158	CU-15KD	15	Satin	± 0.15	175	15	0.5	10g
111159	CU-30KD	30			335	25	1	65g
111293	CU-60KD	60		640	30	1.2	180g	
111294	CU-100KD	100		1050	35	1.5	425g	
111261	CU-15KDF	15		± 0.15	175	15	0.5	10g

# HOOK STAINLESS STEEL RULER K Aidan

Multi use scale with hook

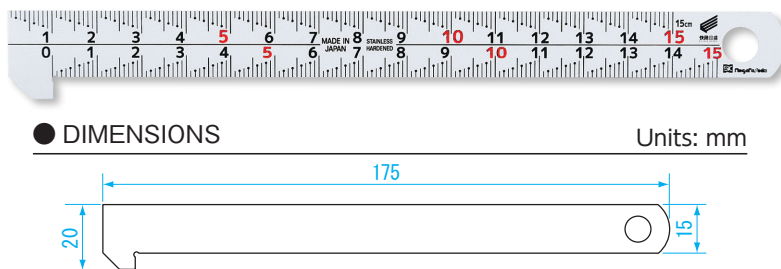

**USE**

- Dimensional measurement from the end side and simplified measurement of C chamfering

**MATERIAL**

- Stainless steel (SUS420J2)

**FEATURES**

- Ruler with hook on the end of scale
- Stepped length of linear graduations by 1mm for easy-to-read
- Sequential graduation numbers and dot marking every 2mm for prevention of misreading
- Edges are finished smoothly to prevent marring surfaces

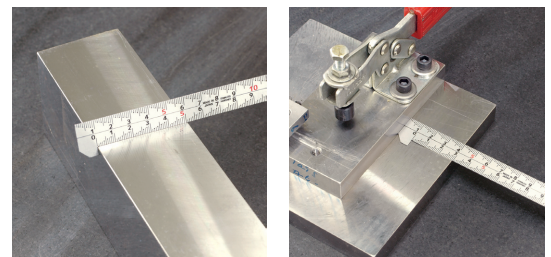

Order No.	Model No.	Nominal Size (cm)	Finish	Accuracy (mm)	Length (mm)	Width (mm)	Thickness (mm)	Weight
111105	FS-15KD	15	Satin	± 0.15	175	20	0.5	10g

RULER  
TRIANGLE RULER  
TAPE MEASURE  
CARPENTERS SQUARE



## VERTICAL STAINLESS STEEL RULER KAIDAN



For depth measurement of machines and jigs.  
Convenient vertical graduation numbers for depth measurement.

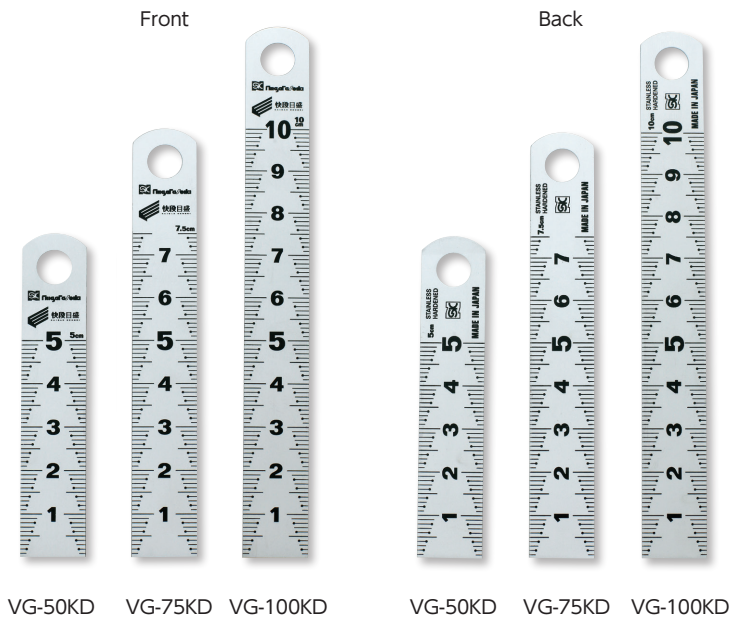

### USE

- For depth measurement of machines and jigs

### MATERIAL

- Stainless steel

### FEATURES

- Convenient vertical graduation numbers for depth measurement
- Stepped length of linear graduations by 1mm and point marking every 2mm for easy-to-read

Order No.	Model No.	Nominal Size (cm)	Accuracy (mm)	Graduation (mm)	Length (mm)	Width (mm)	Thickness (mm)	Weight
111426	VG-50KD	5	± 0.15	1	75.2	15	0.5	4.0g
111427	VG-75KD	7.5			100.3			5.5g
111428	VG-100KD	10			125.2			7.0g



## SNAP-OFF RULER KAIDAN

Solution for those who cut and customize ruler at a desired length.  
Snappable with hand at every 10mm.

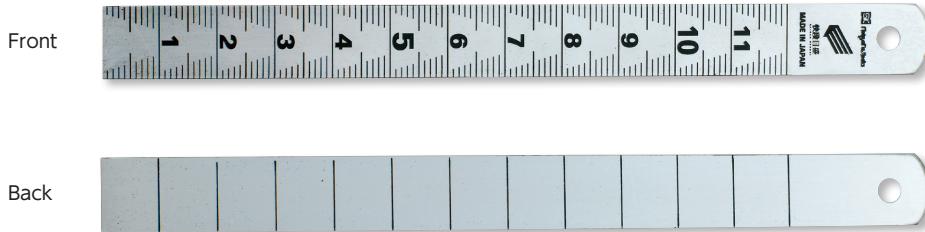

### USE

- For length measurement of short range

### MATERIAL

- Carbon tool steel

### FEATURES

- Snappable at every 10mm
- No cutter needed
- Stepped length of graduations by 1mm for easy-to-read

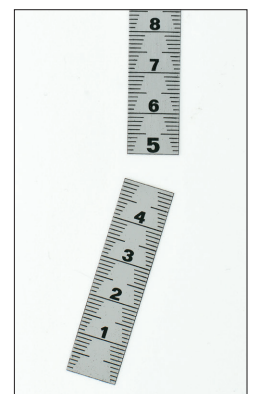

Snappable at every 10mm

Order No.	Model No.	Nominal Size (cm)	Accuracy (mm)	Graduation (mm)	Length (mm)	Width (mm)	Thickness (mm)	Weight
111429	BS-150KD	12	± 0.15	1	146	12.7	0.2	4.1g



# SCALE STICKER K Aidan

Useful scale sticker with Kaidan graduation

### Stick and be a ruler



Mobile phone, planner...



Scales (for weight and length measurement at once)

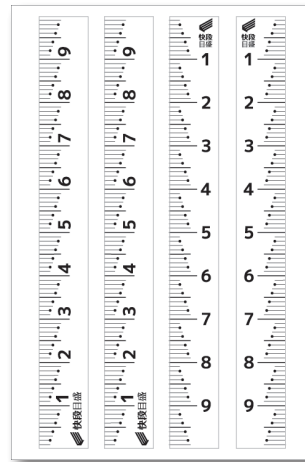

Black colored graduation on white sheet

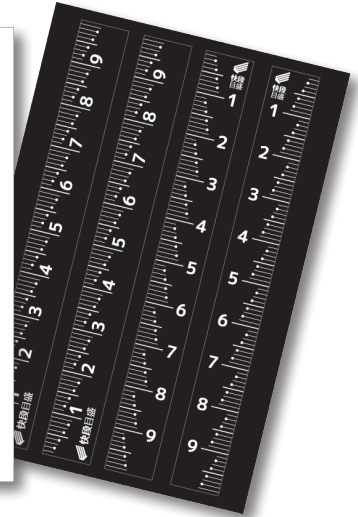

White colored graduation on black sheet

### USE

- For length measurement

### MATERIAL

- PET (Polyethylene terephthalate)

### FEASTURES

- Strong adhesion but easily removable

### FEATURES

- Two stickers (black & white 1 each)

Order No.	Model No.	Nominal Size (cm)	Sticker length (mm)	Sticker width (mm)	Weight
111329	MSL-10KD	9.9	100	10.0	1g



# POCKET RULER WITH DEPTH CLIP K Aidan

New stepped millimeter graduations prevents misreading

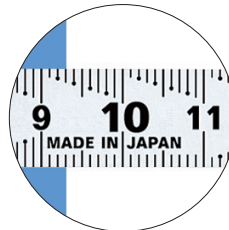

### USE

- For measuring dimensions, drawing and scribing

### MATERIAL

- Stainless steel (SUS420J2)

### FEATURES

- Stepped length of linear graduations by 1 mm for easy-to-read
- Sequential graduation numbers and dot marking every 2mm for prevention of misreading
- Can be used as depth gauge by sliding clip along scale
- With clip for not-to-fall-off
- Edges are finished smoothly to prevent marring surfaces
- Satin finish



With clip for easy carrying

Order No.	Model No.	Size (cm)	Finish	Length (mm)	Width (mm)	Thickness (mm)	Weight
009903	SVC-15KD	15	Satin	160	12	0.5	8g



RULER

TRIANGLE RULER

TAPE MEASURE

CARPENTERS SQUARE

# RULER STOPPER FOR DEPTH MEASUREMENT

Attach to ruler for scribing and depth measurement

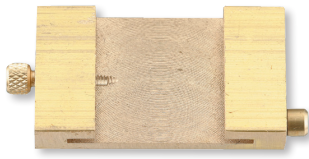
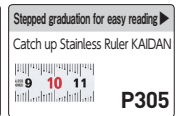
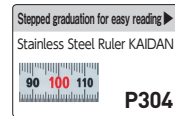

SD-300

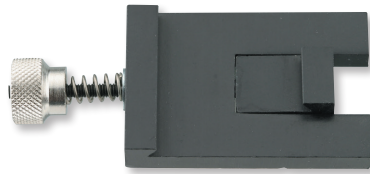

SD-6010

**USE**

- For accurate scribing and measurement of width, height and depth

**MATERIAL**

- Brass (SD-150·SD-300)
- Aluminum (SD-6010)

**FEATURES**

- Slide and screw on ruler for depth measurement
- Convenient size for metal and woodworking use
- Attachable to JIS rulers

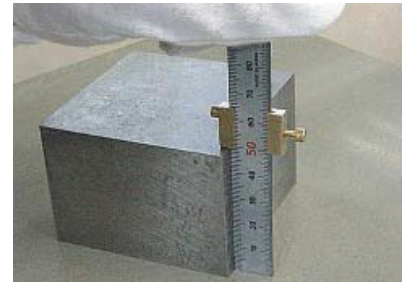
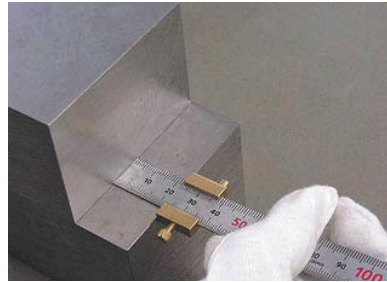

Order No.	Model No.	Type	Length (mm)	Thickness (mm)	Weight
006843	SD-150	For 150mm ruler	15	5	10g
006844	SD-300	For 300mm ruler	20	6	23g
006845	SD-6010	For 600 · 1000mm ruler	30	13	26g



# STAINLESS STEEL RULER KAIDAN WITH RULER STOPPER



Ruler stopper for repeated scribing and depth measurement.  
Ruler comes with ruler stopper.

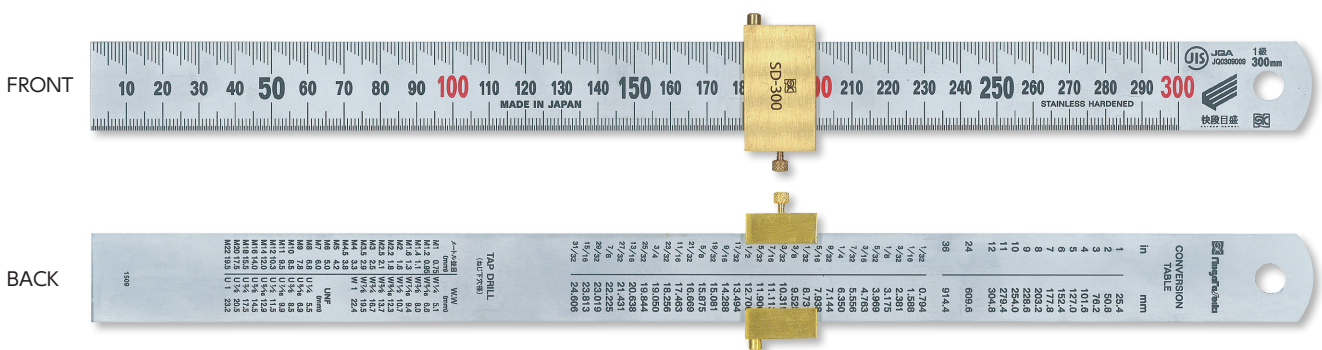

SV-300DKD

**USE**

- Accurate scribing and measuring depth, height, width

**MATERIAL**

- Ruler: Stainless steel (SUS420J2)
- Ruler stopper: Brass

**FEATURES**

- Ruler with ruler stopper
- Edges are thread-chamfered for safety

Order No.	Model No.	Nominal Size (mm)	Length (mm)	Width (mm)	Thickness (mm)	Weight
111298	SV-150DKD	150	175	32	5	20g
111299	SV-300DKD	300	335	45	6	86g



# T-SHAPE RULER K Aidan

For measuring dimensions and scribing from the edge of object

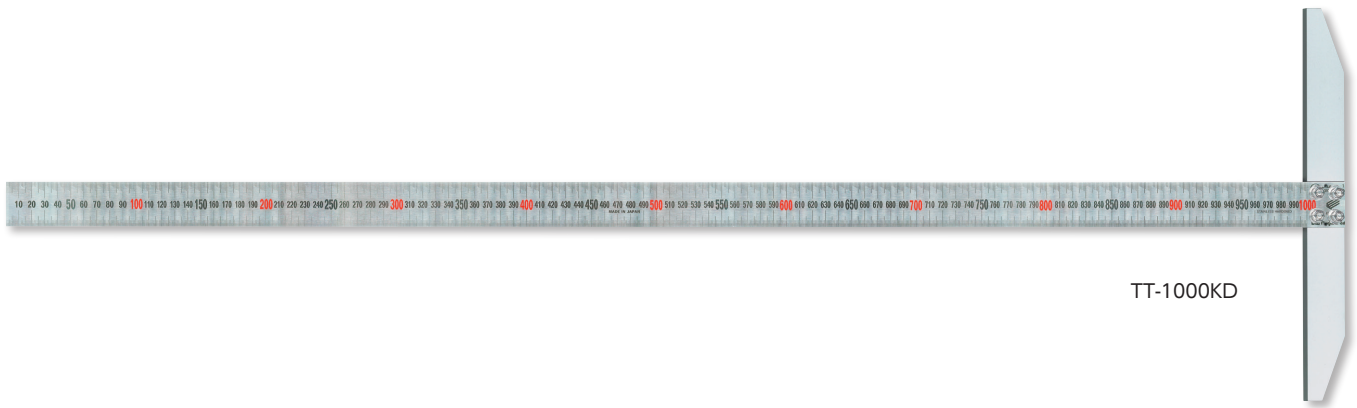

TT-1000KD

### USE

- For measuring dimensions and scribing from the edge of object

### MATERIAL

- Base: Aluminum
- Scale: Stainless steel (SUS420J2)

### FEATURES

- For measuring dimensions and scribing from the edge of object

Order No.	Model No.	Nominal Size (mm)	Accuracy (mm)	Length (mm)	Base Width (mm)	Thickness (mm)	Weight
111300	TT-1000KD	1000	± 0.20	1300	300	16	640g
111301	TT-2000KD	2000	± 0.30	2400			1530g



# CIRCUMFERENCE MEASURING TAPE (CIRCO METER) K Aidan **NEW!**



For circumference and diameter measurement at the same time



CUJ-2200BKD

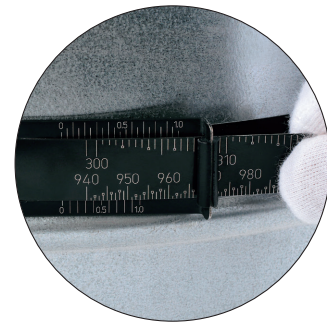

### USE

- For measuring circumference and diameter of large round parts

### MATERIAL

- Stainless steel

### FEATURES

- Black-and-white and stepped length of linear graduations by 1mm and dot marking every 2mm for easy-to-read
- Circumference and diameter measurement at the same time

### SPECIFICATIONS

- Tape width: 16mm
- Dimensions of reading area: W25×L130mm

Order No.	Model No.	Measuring Range [dia.] (mm)	Accuracy [dia.] (mm)	Measuring Range [circumference] (mm)	Accuracy [circumference] (mm)	Weight
<b>NEW!</b> 111362	CUJ-950BKD	φ 20 ~ 300	± 0.05	60~950	±0.1	50g
<b>NEW!</b> 111363	CUJ-2200BKD	φ 300 ~ 700		940~2200		82g
<b>NEW!</b> 111364	CUJ-3460BKD	φ 700 ~ 1100		2190~3460		114g
<b>NEW!</b> 111365	CUJ-4720BKD	φ 1100 ~ 1500		3450~4720		150g



# ALUMINUM RULER K Aidan



New stepped millimeter graduations prevent misreading

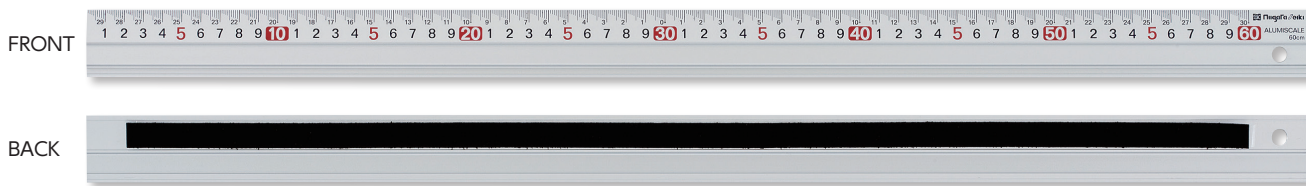

With non-slip sticker (except AS-15), and grip groove

AS-60

**USE**

- For measuring distance, cutting and/or scribing

**MATERIAL**

- Aluminum

**FEATURES**

- Stepped length of linear graduations by 1mm for easy-to-read
- Colored numbers and graduations (Navy & Red) is easy to distinguish the lines and graduations when drawing
- Centered-zero secondary markings (AS-30·AS-60·AS-100)
- With non-slip sticker (except AS-15), and grip groove



Order No.	Model No.	Nominal Size (cm)	Center-zero secondary marking (Yes/No)	Accuracy (mm)	Length (mm)	Width (mm)	Thickness (mm)	Weight
111165	AS-15	15	None	± 0.16	180	35	5	36g
111166	AS-30	30	Yes	± 0.20	330			65g
111167	AS-45	45	None	± 0.25	480			95g
111168	AS-60	60	Yes	± 0.28	630			124g
111169	AS-100	100		± 0.40	1030			203g



# ALUMINUM SAFETY CUTTING RULER K Aidan



Suitable for cutting by non-slip sticker and stainless steel back plate

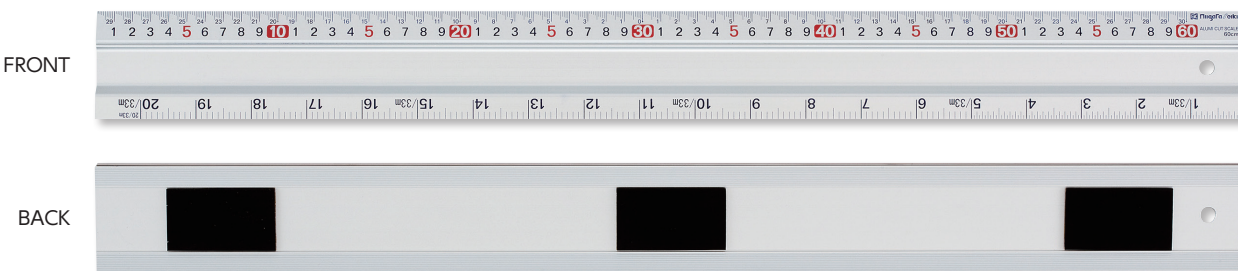

Non-slip sticker and stainless steel back plate included

ACS-60

**USE**

- For measuring dimensions, drawing a straight line, cutting and scribing

**MATERIAL**

- Aluminum

**FEATURES**

- Stepped length of linear graduations by 1mm for easy-to-read
- Colored numbers and graduations (Navy & Red) is easy to distinguish the lines and graduations when drawing
- Centered-zero secondary markings
- Non-slip sticker and stainless steel back plate



With stainless steel back plate to protect blade when used as cutting guide

Order No.	Model No.	Nominal Size (cm)	Center-zero secondary marking (Yes/No)	Accuracy (mm)	Length (mm)	Width (mm)	Thickness (mm)	Weight
006851	ACS-60	60	Yes	± 0.28	630	61	9	330g
006852	ACS-100	100		± 0.40	1030			530g
006853	ACS-150	150		± 0.55	1530			770g
006854	ACS-200	200		± 0.70	2030			1020g

Optimal for cutting with no-slip backing and Stainless plate. Handle to help stabilize work.

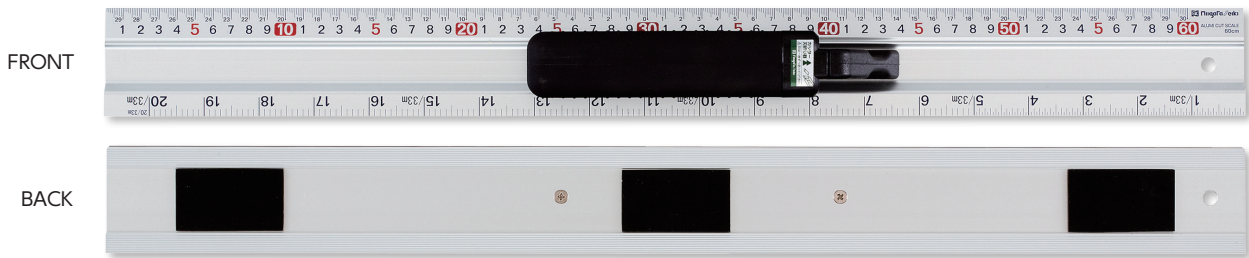

USE Non-slip sticker and stainless steel back plate included

ACS-60H

●For measuring dimensions, drawing a straight line, cutting and scribing

MATERIAL

●Aluminum

FEATURES

- Stepped length of linear graduations by 1 mm for easy-to-read
- Handle to stabilize while cutting
- Slot in handle for snapping off knife blade
- Colored numbers and graduations (Navy & Red) is easy to distinguish the lines and graduations when drawing
- Centered-zero secondary markings
- With non-slip sticker, and stainless steel back plate



Handle has slot for blade removal



With Stainless steel plate to protect blade when used as cutting guide

Order No.	Model No.	Size (cm)	Center-zero secondary marking (Yes/No)	Accuracy (mm)	Length (mm)	Width (mm)	Thickness (mm)	Weight
006855	ACS-60H	60	Yes	± 0.28	630	61	58	500g
006856	ACS-100H	100		± 0.40	1030			700g
006857	ACS-150H	150		± 0.55	1530			940g
006858	ACS-200H	200		± 0.70	2030			1190g

Handy ruler made by anti-rust and energize-retardant material



PFR-100CKD

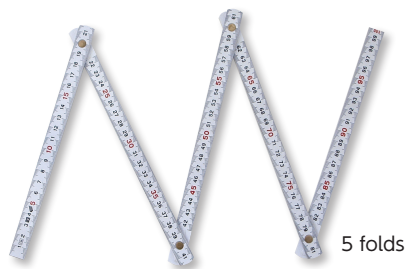

5 folds

Glass-reinforced plastic

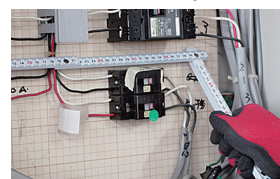

Anti-rust and energize-retardant material

Click locking joints



Stop at 90° and 180°

USE

●For length measurement

MATERIAL

●Glass-reinforced plastic

FEASTURES

- Stepped length of linear graduations by 1 mm for easy-to-read
- Handy and foldable
- Click locking joints at 90° and 180°

SPECIFICATIONS

- Five folds
- Accuracy full length: ±1.5mm / 1m

Order No.	Model No.	Nominal Size	Width (mm)	Thickness (mm)	Weight
111349	PFR-100CKD	1m	15	3.1	60g



# ACRYLIC GRID RULER K Aidan / Cutting Acrylic Grid Ruler K Aidan

Available in three different sizes and two different types

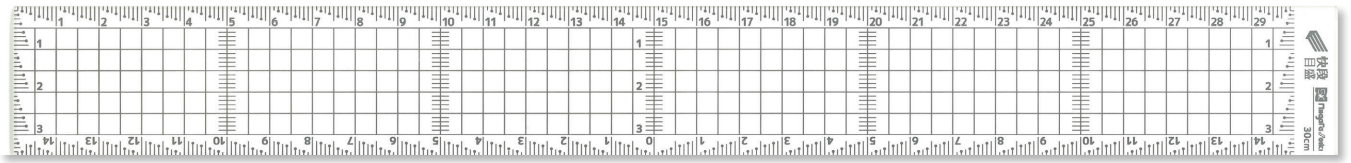

AGS-30KD, CAGS-30KD

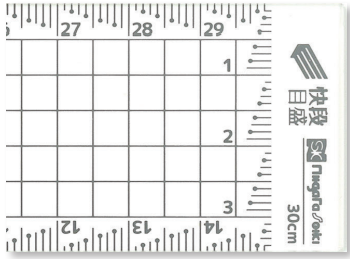

**K Aidan graduation & dots on every 2mm**

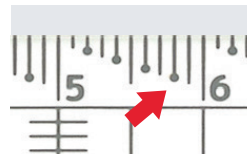

Prevents from miss-scale reading

**"0" origin on the center (Back side ruler)**

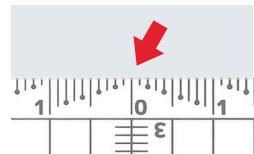

Convenient when measuring in sideways

**Gray colored graduations**

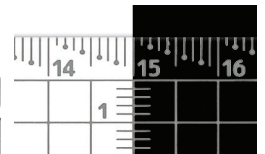

Contrasting coloring improve visibility

**USE**

- For measuring and drawing
- For cutting work (CAGS-15KD, CAGS-30KD, CAGS-50KD)

**MATERIAL**

- Acrylic (AGS-15KD, AGS-30KD, AGS-50KD)
- Acrylic and stainless steel (CAGS-15KD, CAGS-30KD, CAGS-50KD)

**FEATURES**

- Stepped length of linear graduations by 1mm and dot marking every 2mm for easy-to-read
- Back side scale: "0" in the center
- Gray colored graduations and numbers
- "0" origin at end edge for height and depth measurement

**"0" origin at end edge**

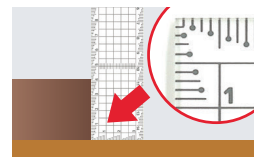

Suitable for height and depth measurement

**With stainless steel plate**



Protect the product from cutter scratch (CAGS series only)

Order No.	Model No.	Nominal Size (cm)	Product type	Length (mm)	Width (mm)	Thickness (mm)	Weight
111307	AGS-15KD	15	—	160	30	2	11g
111308	AGS-30KD	30		310	35	2	26g
111309	AGS-50KD	50		526	60	2	75g
111310	CAGS-15KD	15	Cutting	160	30	3	17g
111311	CAGS-30KD	30		310	35	3	38g
111312	CAGS-50KD	50		526	60	3	111g

RULER

TRIANGLE RULER

TAPE MEASURE

CARPENTERS SQUARE



# BAMBOO RULER K Aidan

High quality Japanese bamboo material



BR-30CKD

**USE**

- For length measurement

**MATERIAL**

- Bamboo

**FEATURES**

- Stepped length of linear graduations by 1mm for easy-to read
- Upper graduation: "0" origin on the left edge, Lower graduation: "0" origin on the right edge

**SPECIFICATIONS**

- Graduation: 10cm from both ends: every 1mm / 10cm in the center: every 2mm

Order No.	Model No.	Nominal Size (cm)	Length (mm)	Width (mm)	Thickness (mm)	Weight
111304	BR-30CKD	30	300	22	3.5	23g
111305	BR-50CKD	50	500	22	3.5	36g
111306	BR-100CKD	100	1000	28	4.5	99g





# TRIANGULAR SCALE RULER K Aidan (ARCHITECTURE USE)



New stepped millimeter graduations prevents misreading



### Accuracy

Length (mm)	Tolerance (mm)
50 and less	± 0.1
More than 50 to less than 100	± 0.2
More than 100 to less than 150	± 0.3
More than 150 to less than 300	± 0.4



1/50, 1/200mm



1/100, 1/200mm



1/300, 1/250mm

### USE

- For drafting reading scaled drawing

### MATERIAL

- ABS

### FEATURES

- Stepped length of linear graduations for easy-to-read
- All number reading type
- Laser marked graduation

### SCALE SPECIFICATIONS

- Scale: 1/20, 1/50, 1/100, 1/200, 1/250, 1/300

Order No.	Model No.	Length (mm)	Width (mm)	Thickness (mm)	Weight
111148	TSB-15KD	170	15	14	11g
111149	TSB-30KD	325	25	22	54g



# ALUMINUM TRIANGULAR SCALE RULER K Aidan (ARCHITECTURE USE)

Graduation of 1/20 scale is 0.5 step

New stepped millimeter graduations prevents misreading

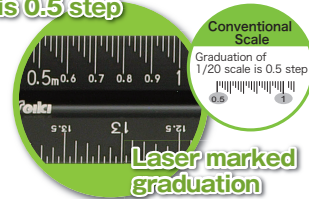

### Accuracy

Length (mm)	Tolerance (mm)
50 and less	± 0.06
More than 50 to less than 100	± 0.07
More than 100 to less than 150	± 0.08
More than 150 to less than 300	± 0.09



1/20, 1/50mm



1/100, 1/200mm



1/250, 1/300mm

### USE

- For drafting reading scaled drawing

### MATERIAL

- Aluminum

### FEATURES

- Stepped length of linear graduations for easy-to-read
- All number reading type
- Laser marked graduation

### SCALE SPECIFICATIONS

- Scale: 1/20, 1/50, 1/100, 1/200, 1/250, 1/300

Order No.	Model No.	Length (mm)	Width (mm)	Thickness (mm)	Weight
111250	TSBA-15KD	170	15	14	18g
111251	TSBA-30KD	325	25	22	60g



## ALUMINUM TRIANGULAR SCALE RULER KAIDAN (GENERAL USE)

New stepped millimeter graduations prevents misreading

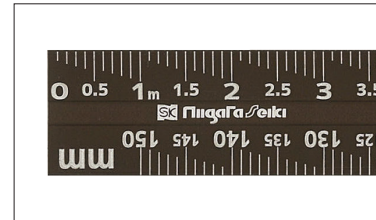
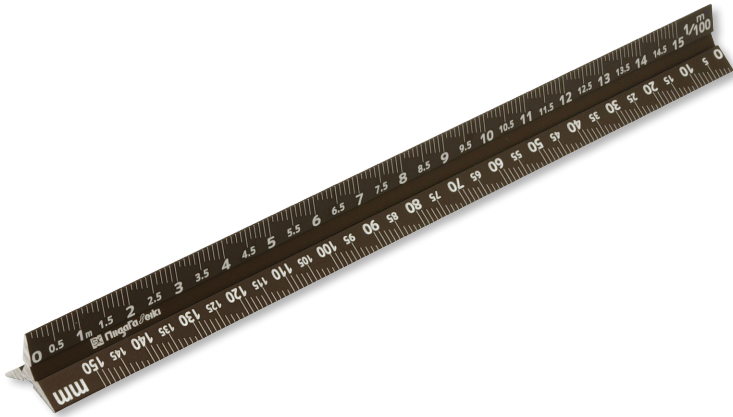

Enlarged view (scale: 1/100m, 1/1mm)

### Accuracy

Length (mm)	Tolerance (mm)
50 and less	±0.06
More than 50 to less than 100	±0.07
More than 100 to less than 150	±0.08

### USE

- For drafting reading scaled drawing

### MATERIAL

- Aluminum

### FEATURES

- Stepped length of linear graduations for easy-to-read
- All number reading type
- Laser marked graduation

### SCALE SPECIFICATIONS

- Scale: 1/1, 1/100, 1/150, 1/200, 1/250, 1/300



1/100m, 1/1mm



1/150, 1/200m



1/250, 1/300m

Order No.	Model No.	Length (mm)	Width (mm)	Thickness (mm)	Weight
111254	TSGA-15KD	160	15	14	18g



## ALUMINUM TRIANGULAR SCALE RULER KAIDAN (REAL-ESTATE SURVEYOR USE)

New stepped millimeter graduations prevents misreading

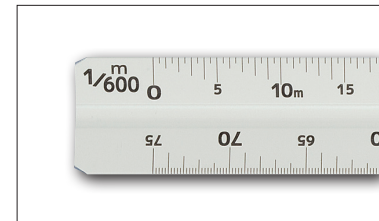
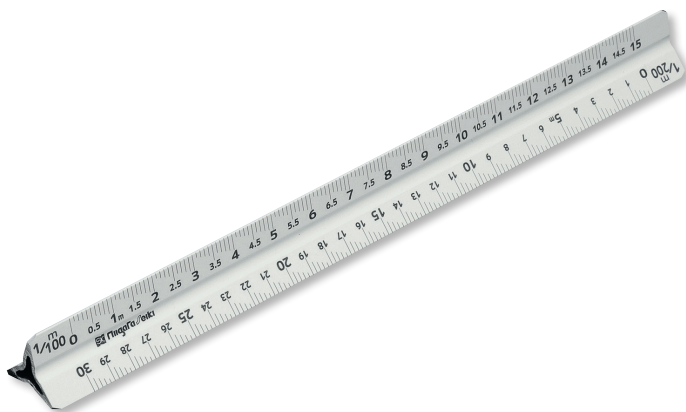

Enlarged view (scale: 1/500, 1/600m)

### Accuracy

Length (mm)	Tolerance (mm)
50 and less	±0.06
More than 50 to less than 100	±0.07
More than 100 to less than 150	±0.08

### USE

- For drafting reading scaled drawing

### MATERIAL

- Aluminum

### FEATURES

- Stepped length of linear graduations for easy-to-read
- All number reading type
- Laser marked graduation

### SCALE SPECIFICATIONS

- Scale: 1/100, 1/200, 1/250, 1/300, 1/500, 1/600



1/100, 1/200m



1/250, 1/300m

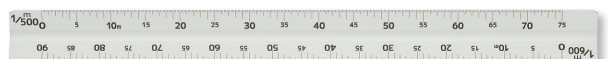

1/500, 1/600m

Order No.	Model No.	Length (mm)	Width (mm)	Thickness (mm)	Weight
111255	TSIA-15KD	170	15	14	18g

RULER

TRIANGLE RULER

TAPE MEASURE

CARPENTERS SQUARE



# AUTO LOCK TAPE MEASURE PRO K Aidan



With out-locking anti-retraction tape measure



ALCP-2555KD



RULER

TRIANGLE RULER

TAPE MEASURE

CARPENTERS SQUARE

### Rubber body



Non-slip rubber grip perfectly fits hand

### Auto-locking function

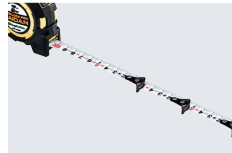

Auto-lock is engaged when tape is pulled for anti-retraction

### With belt clip and strap



Easy to carry around

### Nylon coating tape

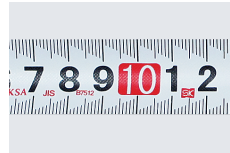

Highly durable against wear

### Hardened end-hook

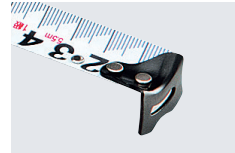

Ensures durability

### USE

- Measure dimensions

### MATERIAL

- Body: ABS, Rubber
- Tape: SK4 tool steel (Nylon coated)

### FEATURES

- Stepped length of linear graduations by 1 mm for easy-to-read
- Repeating digit type for large, easy to read numbers
- Auto-lock is engaged when tape is pulled for anti-retraction
- Water resistant Nylon-coated tape
- JIS class 1 tape
- Non-slip rubber grip

Order No.	Model No.	Max measuring length (m)	Tape width (mm)	Weight
111196	ALCP-1620KD	2.0	16	110g
111197	ALCP-1635KD	3.5		140g
111198	ALCP-1955KD	5.5	19	270g
111199	ALCP-2555KD		25	340g

Strong rigidity tape resists to folding and deflection



LCG-1950KD



Three colored printing (black, red and blue), easy to distinguish the graduations



Back side is vertical scale

**USE**

- Measure dimensions

**MATERIAL**

- Body: ABS, Rubber
- Tape: SK4 tool steel (Nylon coated)

**FEATURES**

- Strong rigidity tape resists to bending and deflection
- Repeating digit type for large, easy to read numbers
- Three colored printing (black, red and blue), easy to distinguish the graduations
- Water resistant Nylon-coated tape
- JIS class 1 tape
- Non-slip rubber grip

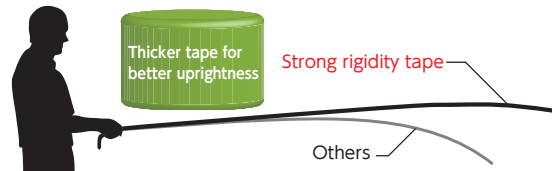

Order No.	Model No.	Max measuring length (m)	Tape Width (mm)	Body Color	Weight
111256	LCG-1950KD	5.0	19	White	270g
111257	LCG-2550KD		25	Black	320g

KAIDAN LOCK GUARD with its dedicated holder



LCG-2550HKD



CVH-45



Simple "slot-in" design

**MATERIAL**

- CVH-45: ABS

**FEATURES**

- CVH-45: Dedicated holder for KAIDAN LOCK GUARD. Easy and quick operation when attaching/ detaching the tape measure to/ from the holder.
- LCG-2550HKD: KAIDAN LOCK GUARD LCG-2550KD plus TAPE MEASURE HOLDER CVH-45 in one set

Order No.	Product Name	Model No.	Max Measuring Length	Tape Width (mm)	Attachable Belt Size		Weight
					Width (mm)	Thickness (mm)	
111348	KAIDAN LOCK GUARD WITH HOLDER	LCG-2550HKD	5.0m	25	45	7	340g
111361	TAPE MEASURE HOLDER	CVH-45	-	-			27g



## TAPE MEASURE (KAIDAN LOCK POCKET)



With convenient magnetic hook for attaching to metal surface

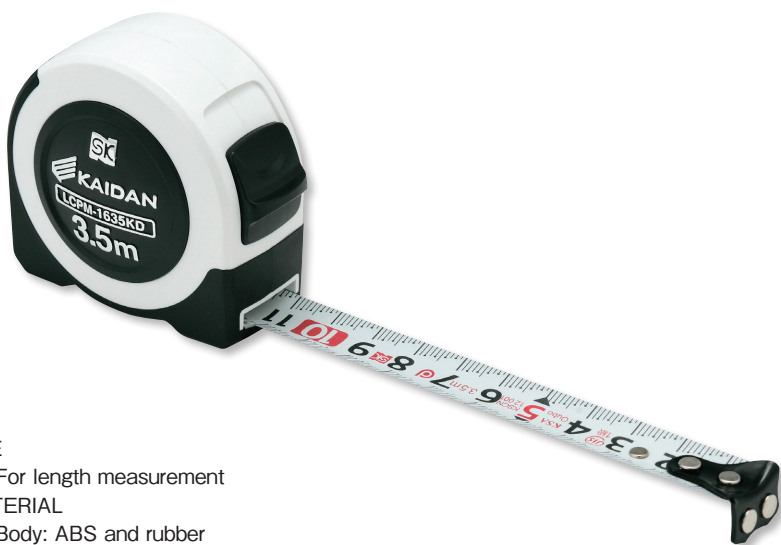

Pocket size



Convenient magnetic hook

**USE**

- For length measurement

**MATERIAL**

- Body: ABS and rubber
- Tape: SK4 (resin coated)

**FEATURES**

- Neodymium magnetic hook for attaching to metal surface
- Pocket size
- Stepped length of linear graduations by 1 mm for easy-to-read
- JIS class 1 tape



Sequential marking tape with dot on every 2mm for easy scale reading

Order No.	Model No.	Max Measuring length (m)	Tape Width (mm)	Weight
111360	LCPM-1635KD	3.5	16	123g



## TAPE MEASURE (AUTO LOCK KAIKIDAN)



With out-locking anti-retraction tape. Handy model of AUTO LOCK series.



ALC-1635KD

With convenient carabiner clip



For attaching to belt loop or storing everywhere with hook

Rubber plating on both sides



Designed to fit for both right and left handed

**USE**

- For length measurement

**MATERIAL**

- Body: ABS and rubber
- Tape: SK4 (resin coated)

**FEATURES**

- Auto-lock is engaged when tape is pulled for anti-retraction
- With convenient carabiner clip. Light weight and handy.
- Stepped length of linear graduations by 1 mm for easy-to-read
- Dot marking-every 2mm



Sequential graduation numbers and dot marking every 2mm for easy-to-read

Order No.	Model No.	Max Measuring Length (m)	Tape Width (mm)	Weight
111342	ALC-1320KD	2.0	13	88g
111343	ALC-1635KD	3.5	16	135g



# TAPE MEASURE (KAIDAN LOCK)



New stepped millimeter graduations prevents misreading



### USE

- For length measurement

### MATERIAL

- Body: ABS and rubber
- Tape: SK4 (resin coated)

### FEATURES

- Stepped length of linear graduations by 1 mm for easy-to-read
- Dot marking-every 2mm
- Sequential marking tape



### Hardened end-hook



Ensures durability

### With convenient belt clip



Easy to carry around

Order No.	Model No.	Max Measuring Length (m)	Tape Width (mm)	Body Color	Weight
111336	LC-1620KD	2.0	16	Pink	90g
111337	LC-1635KD	3.5		Yellow	122g
111338	LC-1955KD	5.5	19	Green	210g
111339	LC-2555KD		25	Blue	270g



# TAPE MEASURE (KAIDAN MINI)



Mini tape measure with quality JIS CLASS 1 tape



### Compact



Handy size

### With convenient carabiner clip

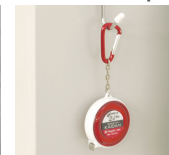

Portable and easy to store

### With 0 adjustment end-hook

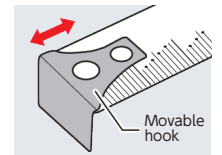

For fine-adjustment of measuring point

### USE

- For length measurement

### MATERIAL

- Body: ABS and rubber
- Tape: SK4 (resin coated)

### FEATURES

- 9mm width tape, convenient when measuring small objects
- With 0 adjustment end-hook
- JIS class 1 tape
- Stepped length of linear graduations by 1 mm for easy-to-read
- Dot marking-every 2mm
- Sequential marking tape

### Comparison with 25mm width tape

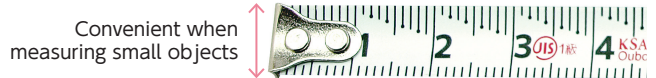
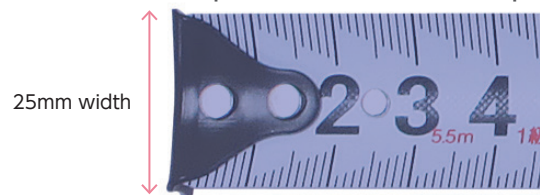

Order No.	Model No.	Max Measuring Length (m)	Tape Width (mm)	Weight
111335	MMF-0902KD	2.0	9	45g



## SEWING TAPE MEASURE K Aidan

Made in Japan. JIS class 1 and antimicrobial tape.



DMA-1215KD



DMB-1215KD

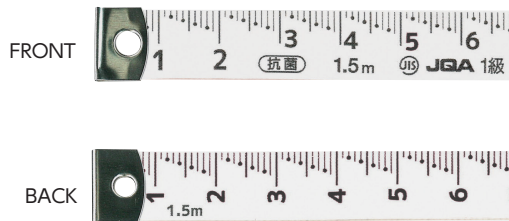

### USE

- For length measurement

### MATERIAL

- Core tape: Fiberglass
- Tape coating: Polyvinyl chloride (antimicrobial)
- Case: ABS (DMA-1215KD)

### FEATURES

- Low elasticity fiberglass tape
- Silent when pulling out the tape (DMA-1215KD)
- Antimicrobial tape
- Stepped length of linear graduations by 1mm for easy-to-read
- Dot marking-every 2mm
- JIS class 1 tape

Order No.	Model No.	Product Type	Max measuring length (m)	Tape Width (mm)	Tape Thickness (mm)	Weight
111333	DMA-1215KD	Cased	1.5	12	0.3	25g
111334	DMB-1215KD	Tape				10g



## LONG TAPE MEASURE K Aidan

Triple speed tape retraction and dust remover attached

Triple Speed tape retraction

Original New Mechanics

Comfortable smooth gear handle

DUST REMOVER MDR-12 prevents sand and dust from getting into the entrance



MDR-12

GFM-30KD

### USE

- For distance measurement

### MATERIAL

- Case: ABS
- Core tape: Fiberglass
- Tape coating: Polyvinyl chloride

### FEATURES

- Four planetary gears and rotation axis allow smooth and quick (triple speed) tape retraction
- Resistant to wear, heat and energize
- Washable
- Stepped length of linear graduations by 1mm for easy-to-read
- Dot marking-every 2mm
- JIS class 1 tape

Order No.	Product name	Model No.	Max Measuring Length (m)	Tape Width (mm)	Tape Thickness (mm)	Tensile force	Accuracy (L=Measuring Length (m))	Weight
111331	LONG TAPE MEASURE K Aidan	GFM-30KD	30	12.5	0.47	20N	±(0.6+0.4L)mm	640g
111332	LONG TAPE MEASURE K Aidan	GFM-50KD	50					890g
111359	DUST REMOVER FOR TAPE MEASURE	MDR-12	-	-	-	-	-	60g

New stepped millimeter graduations prevents misreading

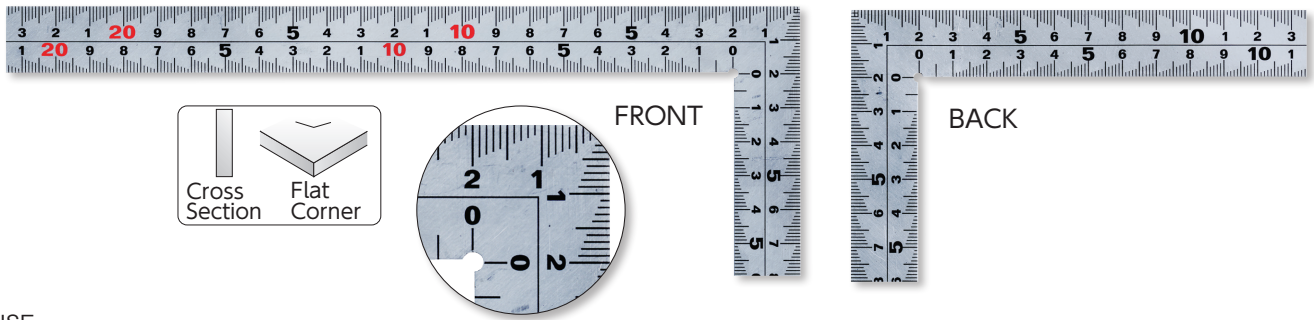

### USE

- Measure dimensions and marking for stone or metal work

### MATERIAL

- Stainless steel

### FEATURES

- Stepped length of linear graduations by 1 mm for easy-to-read
- Highly legible repeated numerals
- Thick blade type protects the product from shock and keep the product shape
- Thin blade type for easy handling (TH-30KD, TH-50KD)
- With a rope hole (MT-30KD, TH-30KD)

Order No.	Model No.	Size	Type	Graduations	Long blade (mm)	Short blade (mm)	Width (mm)	Thickness (mm)	Weight
111190	MT-30KD	30cm	Thick and wide	Four edges, both sides	320	160	20	2.0	145g
111191	MT-50KD	50cm			520	260			235g
111303	TH-30KD	30cm	Thin and wide		320	160		1.0	75g
111302	TH-50KD	50cm			520	260			120g

## MANHOLE DEPTH MEASURING ADAPTER

Measure the step between manhole and road surface when attached to steel square

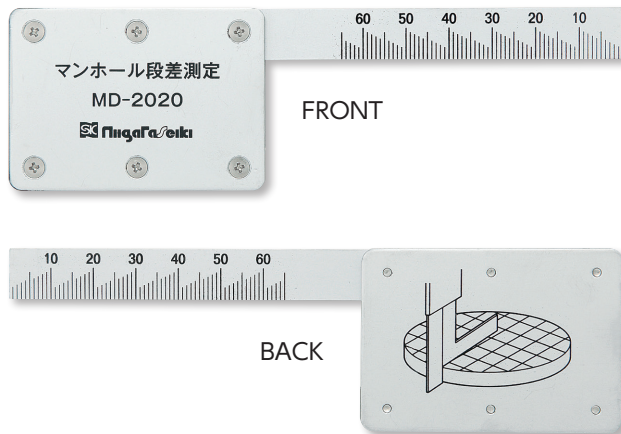

Mount on steel square

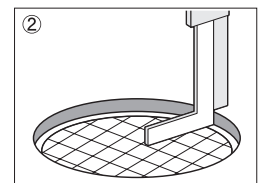
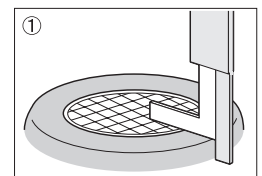

Step measurement between manhole and road surface

### ● DIMENSIONS

Units : mm

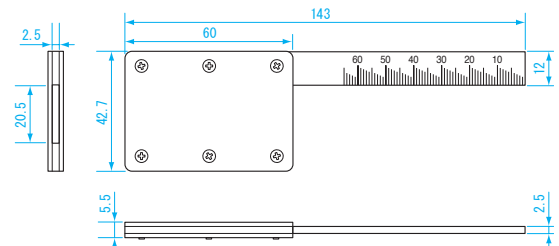

### USE

- For measuring gaps between manhole and road surface
- Applicable steel square: MT-30KD, MT-50KD

### MATERIAL

- Stainless steel

### FEATURES

- Measuring range: ① 65mm
- Horizontal length: ② 143mm

Order No.	Model No.	Accuracy (mm)	Applicable square size (mm)	Weight
006991	MD-2020	± 0.2	Width 20 × Thickness 2.0	100g

RULER

TRIANGLE RULER

TAPE MEASURE

CARPENTERS SQUARE



# CARPENTER'S SQUARE K Aidan WITH MAGNETS



With strong magnets to firmly place it onto metal surface

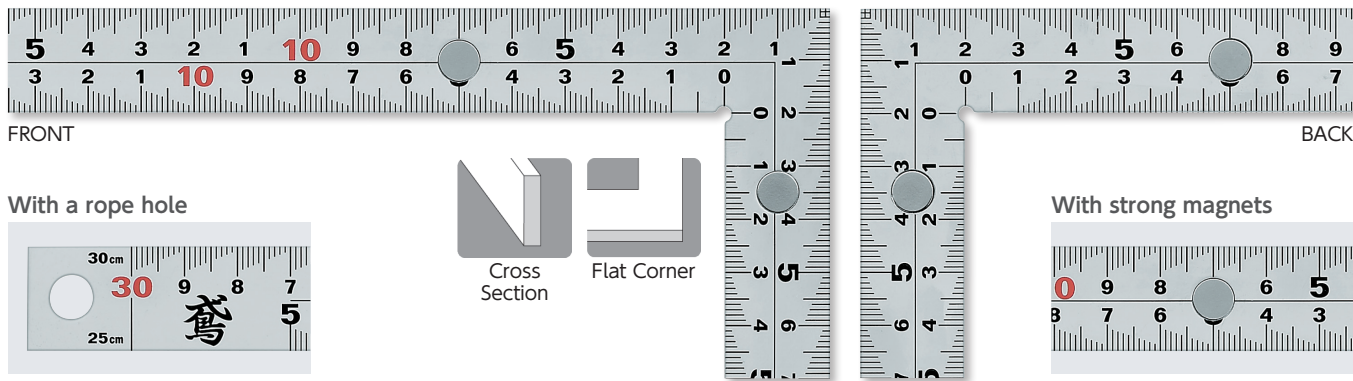

**USE**

- For measuring dimensions and marking

**MATERIAL**

- Stainless steel

**FEATURES**

- With a rope hole
- Suitable size to carry around in a tool bag
- Thick blades protect the product from shock and keep the product shape

Order No.	Model No.	Size	Type	Long blade (Short blade) × Width × Thickness (mm)	Outer Scale (Front & Back are identical)				Accuracy		Weight
					Long blade 30cm	Short blade 15cm	Long blade 25cm	Short blade 10cm	Deviation from a right angle per 100mm length	Tolerance of length	
111317	MT-30CMGKD	30cm	Magnet attached	320(160)×20×2.0	Long blade 30cm	Short blade 15cm	Long blade 25cm	Short blade 10cm	Less than 0.1mm	300mm ±0.2mm	142g



# MEDIUM / LARGE CARPENTER'S SQUARE K Aidan



Sheet metal workshop essential. Measure dimensions, check right angles, and marking work.

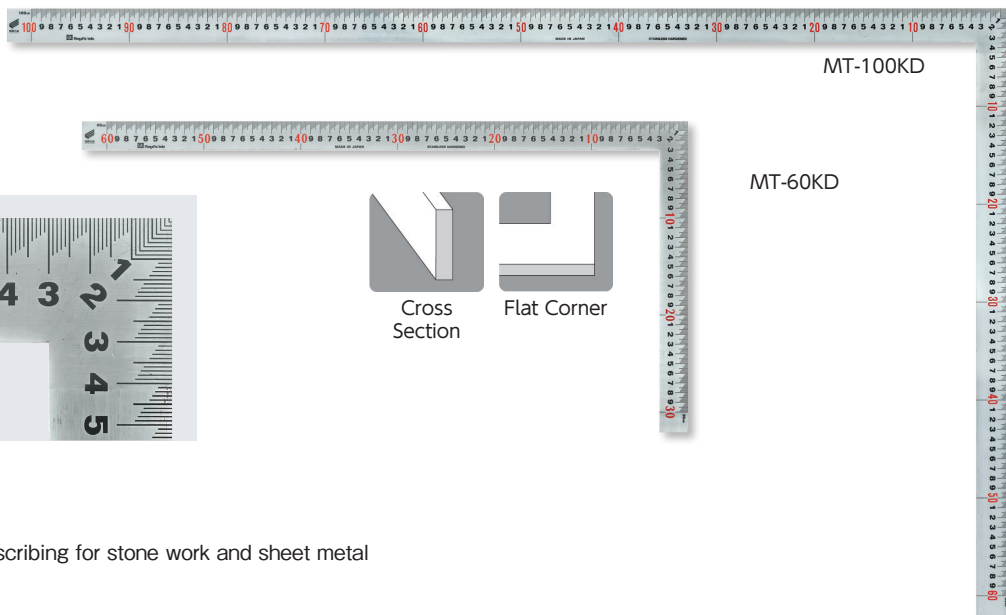

**USE**

- Measuring dimensions and scribing for stone work and sheet metal

**MATERIAL**

- Stainless steel

**FEATURES**

- For working with large material

Order No.	Model No.	Size	Type	Length of Long blade (Short blade) × Width × Thickness (mm)	Outer scale (Front only)		Weight
					Long blade	Short blade	
111296	MT-60KD	60cm	Medium	631(325)×30×2.0	60cm	30cm	420g
111297	MT-100KD	100cm	Large	1026(629)×35×2.5	100cm	60cm	1080g



# CARPENTER'S SQUARE K Aidan (IDENTICAL OUTER / INNER SCALES)



Flat corner thickness type

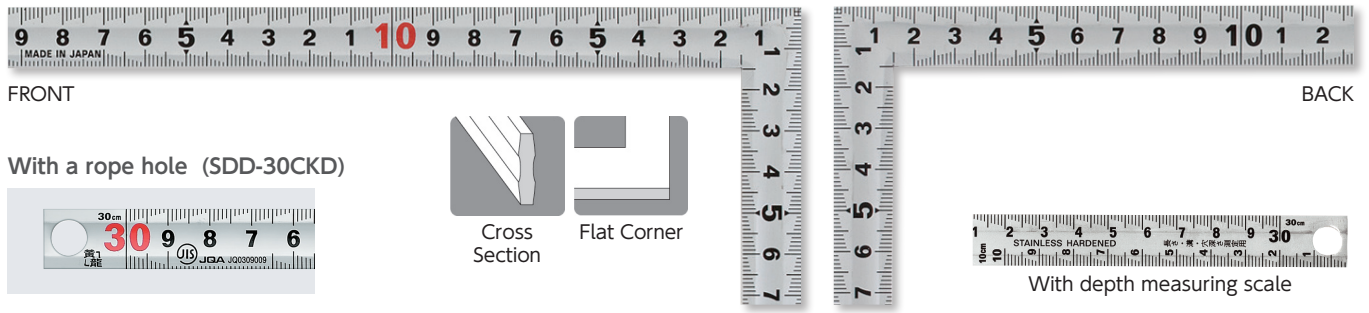

### USE

- For measuring dimensions and marking

### MATERIAL

- Stainless steel

### FEATURES

- Repeated numerals
- Flat corner thickness
- With a rope hole (SDD-30CKD)

Order No.	Model No.	Size	Type	Long blade (Short blade) × Width × Thickness (mm)	Front Scale		Back Scale		Accuracy		Weight
					Long blade	Short blade	Long blade	Short blade	Deviation from a right angle	Tolerance of length	
111188	SDD-30CKD	30cm	Flat corner thickness	320(160)×15×1.3	30cm	15cm	30cm	15cm	Less than 0.1mm per 100mm length	300mm ±0.2mm 500mm ±0.2mm	50g
111189	SDD-50CKD	50cm	Flat corner thickness	520(260)×15×1.3	50cm	25cm	50cm	25cm			90g



# CARPENTER'S SQUARE K Aidan YELLOW GOLD (IDENTICAL OUTER / INNER SCALES)



Oil-repellent coated surface for improved visibility. Yellow gold color.

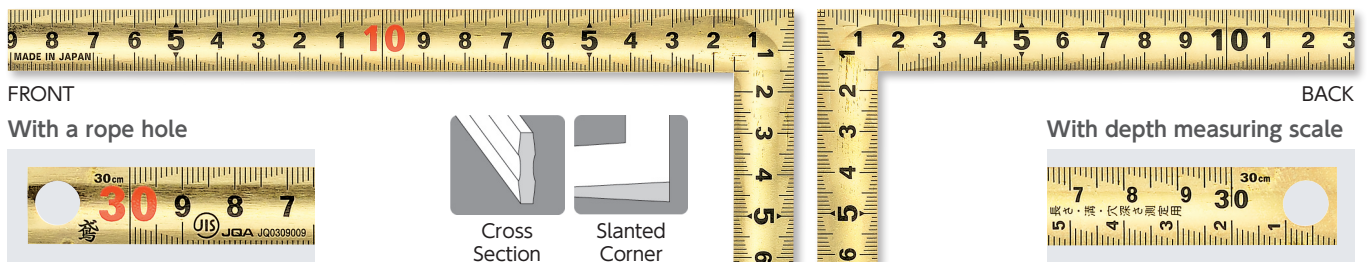

### USE

- For measuring dimensions and marking

### MATERIAL

- Stainless steel

### FEATURES

- Pliable and durable high quality rolled material for long product life
- With a rope hole

Order No.	Model No.	Size	Type	Long blade (Short blade) × Width × Thickness (mm)	Front Scale		Back Scale		Accuracy		Weight
					Long blade	Short blade	Long blade	Short blade	Deviation from a right angle	Tolerance of length	
111316	GCT-30CKD	30cm	Yellow gold	320(160)×15×1.3	30cm	15cm	30cm with depth scale	15cm	Less than 0.1mm per 100mm length	300mm ±0.2mm	61g



# CARPENTER'S SQUARE K Aidan WITH SUB-SCALES



Diagonal, Circumference and depth measuring scales on the back

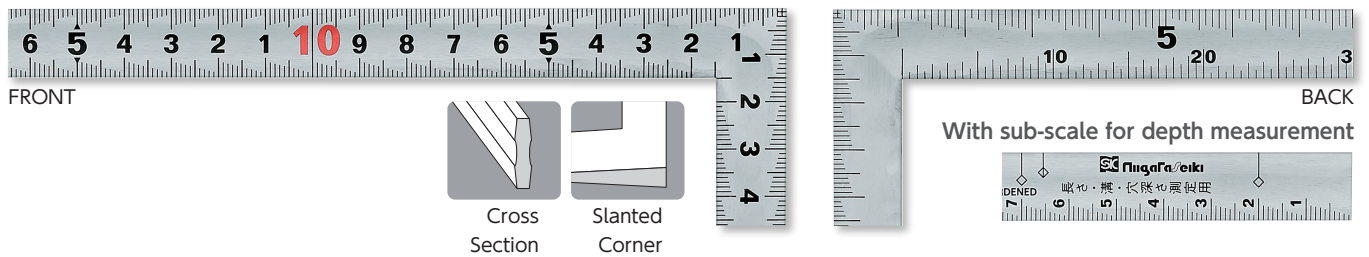

**USE**

- For measuring dimensions and marking

**MATERIAL**

- Stainless steel

**FEATURES**

- Pliable and durable high quality rolled material for long product life
- With Japanese carpenter style diagonal, circumference and depth measuring scales on the back

Order No.	Model No.	Size	Type	Long blade (Short blade) × Width × Thickness (mm)	Front Scale		Back Scale		Accuracy		Weight
					Long blade	Short blade	Long blade	Short blade	Deviation from a right angle	Tolerance of length	
111318	SC-30CKD	30cm	Diagonal & Circumference/ Satin finish	320(160) × 15 × 1.3	30cm	15cm	Diagonal	15cm	Less than 0.1mm per 100mm length	300mm ±0.2mm	50g
111320	SC-50CKD	50cm	Diagonal & Circumference/ Polished finish	520(260) × 15 × 1.3	50cm	25cm	Circumference	25cm		500mm ±0.2mm	90g
111319	NC-50CKD						Depth		90g		



# CARPENTER'S SQUARE K Aidan MINI



Small but usufulle. Easy to carry around.



**USE**

- For measuring dimensions and marking

**MATERIAL**

- Stainless steel

**FEATURES**

- Compact and handy
- With sub scale for depth measurement (Back side)
- With a rope hole



Compact and handy



Order No.	Model No.	Size	Long blade (Short blade) × Width × Thickness (mm)	Front Scale		Back Scale		Weight
				Long blade	Short blade	Long blade	Short blade	
111325	CM-10KD	10cm	110(58) × 12 × 1.2	10cm	5cm	10cm	5cm	20g
111326	CM-15KD	15cm	162(83) × 12 × 1.2	15cm	7.5cm	15cm	7.5cm	26g

Dot marking every 2mm and sequential graduation numbers

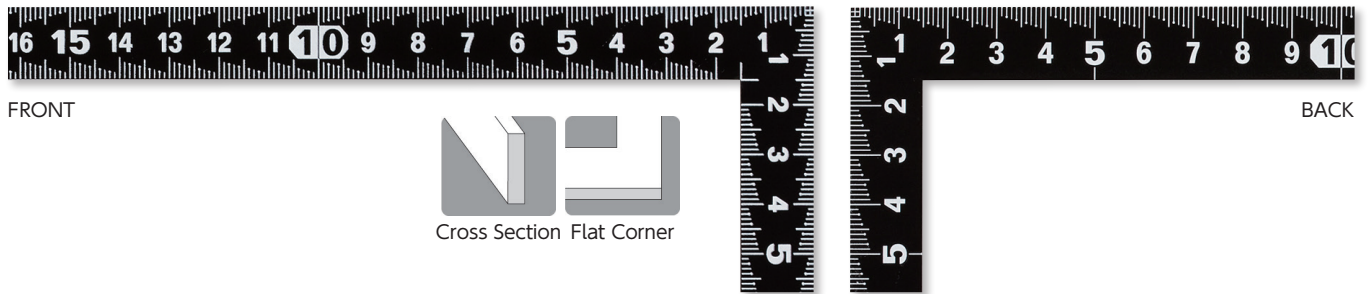

**USE**

- For measuring dimensions and scribing

**MATERIAL**

- Steel

**FEATURES**

- Stepped length of linear graduations by 1mm for easy-to-read
- Dot marking-every 2mm
- Sequential graduation numbers for prevention of misreading

Order No.	Model No.	Size	Long blade (Short blade) × Width × Thickness (mm)	Front Scale		Back Scale		Weight
				Long blade	Short blade	Long blade	Short blade	
111192	CB-15KD	30cm	325(165)×15×1.2	30cm	15cm	30cm	15cm	68g

# DURABLE PLASTIC 3D ANGLE SCRIBING MITRE SQUARE

For marking at 45, 90 and 135 deg. Polycarbonate material allows scratch-free contact to workpiece.

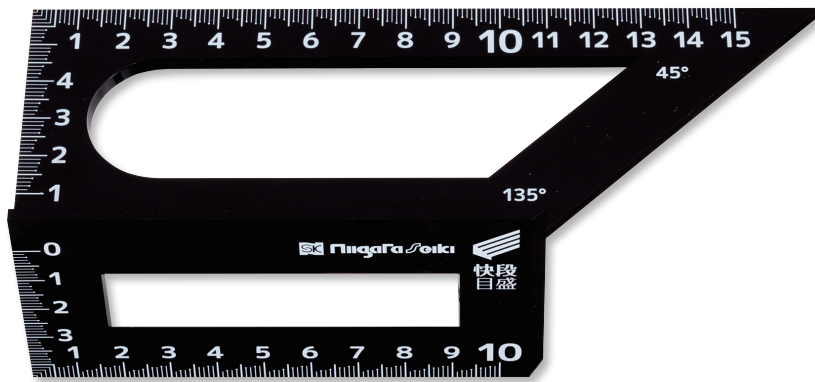

Use example - at 45 deg

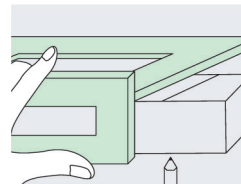

Use example - at 90 deg

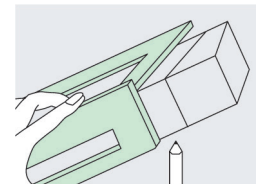

**USE**

- For measuring dimensions and marking

**MATERIAL**

- Polycarbonate

**FEATURES**

- Polycarbonate material for scratch-free contact to workpiece
- With 45deg / 135deg angle indication
- Stepped length of linear graduations by 1mm for easy-to-read

Order No.	Model No.	Size	Total Length × Total Width × Thickness (mm)	Weight
111330	ASQ-100PCKD	15cm	169×63×55	35g