



HIRAYAMA AUTOCLAVE

HICLAVE

HVA-85

HVA-110

OPERATION MANUAL



WARNING:

- Be sure to read this operation manual carefully and handle it properly.

- This manual covers the operation and basic maintenance procedure for the Autoclave HVA-85/110. Proper handling will allow the autoclave to demonstrate its full performance and ensure a long lifetime for the instrument.
- Please confirm that this product conforms to your order, and confirm that it was not damaged during transport. In the event of damaged or broken equipment, please contact our authorized distributor in your region.

- ① No part of this document may be reproduced without permission.
- ② The contents of this document are subject to change without notice.
- ③ This document has been carefully compiled. If you have any questions or necessary information uncovered in the document, please contact our authorized distributor in your region.

Read Carefully Before Using

- Determine the handling person responsible of this product.
- In this manual the following headings are applied to items to which great attention should be given:

 **WARNING :** Precaution indicating an imminent dangerous situation which if not avoided may lead to death or serious injury.

 **CAUTION:** Precaution indicating a dangerous situation which if not avoided may lead to moderate or slight injury.

 **IMPORTANT:** Indicates items you are strongly advised to obey.

 **NOTE:** Items that will aid in proper operation of the equipment.

WARNING:

- Never use the autoclave to sterilize any of the following hazardous materials or substances with alkali content. Sterilization of such objects can cause explosion, corrosion of the working chamber or chamber piping, and deterioration of gaskets.

List of Hazardous Materials

① Explosive substances

- Nitroglycol, nitroglycerin, nitrocellulose, and other explosive nitric esters.
- Trinitrobenzene, trinitrotoluene, picric acid, and other explosive nitro compounds.
- Peracetic acid, methyl ethyl ketone peroxide, benzoyl peroxide, and other organic peroxides.

② Ignitable substances

- Metallic lithium, potassium, sodium, yellow phosphorous, phosphorus sulfide, and red phosphorus.
- Celluloids, calcium carbide (carbide), lime phosphide, and magnesium powder
- Aluminum powder, magnesium powder, and metallic powders other than aluminum powder
- Sodium dithionite (or sodium hydrosulfite)

③ Oxidizing agents

- Potassium chlorate, sodium chlorate, ammonium chlorate, and other chlorates
- Potassium perchlorate, sodium perchlorate, ammonium perchlorate, and other perchlorates.
- Potassium peroxide, sodium peroxide, barium peroxide, and other inorganic peroxides
- Potassium nitrate, sodium nitrate, ammonium nitrate, and other nitrates
- Sodium chlorite and other chlorites • Calcium hypochlorite and other hypochlorites

④ Flammable substances

- Ethyl ether, gasoline, acetaldehyde, propylene oxide, carbon disulfide, and other substances whose flash points range from -30 to 0°C.
- Methanol, ethanol, xylene, benzyl acetate (or amyl acetate), and other substances whose flash points range from 0 to 30°C.
- Kerosene, gas oil, turpenine oil, isopentyl alcohol (or isoamyl alcohol), acetic acid, and other substances whose flash points range from 30 to 65°C.

⑤ Flammable gas (hydrogen, acetylene, ethylene, methane, ethane, propane, butane, and other substances that are gases at a temperature of 15°C under 1 atmospheric pressure.)

- When liquid with salt water and much salinity of salt agar etc. spills in the chamber, blowing, discharge water in the chamber and wipe up drop of water around the lid gasket beautifully. It causes the corrosion of the chamber and the piping when leaving just as it is
- Check that the pressure is below "0Mpa" before opening the lid.

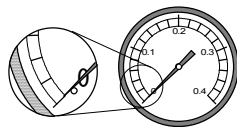

- Absolutely do not attempt to remodel or alter this product.
- Do not use this product near explosive gas, as a few parts used are not explosion proof structure.



CAUTION:

Foreign matter (metals, liquid) may enter through the vent hole. Operating the equipment with such foreign matter inside may cause trouble with the equipment, fire or electric shock.

- Do not forcibly bend, twist, tie or extend the power cord. Do not place heavy objects on the cord. A damaged cord or exposed wire can cause fire or electric shock.
- Never connect the power cord to a power supply other than one of the rated voltage. Connection to such a power supply can cause fire or electric shock.
- If grounded socket is unavailable, ground the equipment using a separate ground wire before connecting the power cord to the power source.
- Never ground to a gas pipe or vinyl chloride water service pipe.
- Raise the lid slowly. When an impact is added to the lid, there is fear which the hinge of the lid damages.
- Close the lid after confirming that no foreign matter is adhering to the section contacting the lid gasket. Foreign matter in this section can cause vapor leaks.
- When using a waste processing bag or other kind of bag and disinfecting, place the bag in the metal mesh holder and then insert it into the chamber. Using the bag “as is” can cause excessive temperatures, pressures, lack-of-water, etc.
- Be careful not to pinch your hands when closing the lid.
- Do not put your face or hands close to the chamber when lifting the lid after operations are complete; steam will gush out of the chamber.
- The lid, chamber, gasket and panel are extremely hot immediately after the completion of operation. Do not touch the equipment or you may get burned.
- Put on heat insulating gloves before removing a substance from the chamber. Do not put hands into the chamber until the steam has been vented.
- Some time is required for liquids to cool. Be sure to check that the temperature has dropped sufficiently before unloading a liquid from the working chamber or burns can result.
- Do not unload the exhaust bottle or drain the chamber when the chamber is under pressure. Boiling water or steam may gush out causing burns.
- Do not remove the exhaust bottle before water in the bottle has sufficiently cooled.
- If any abnormality occurs (e.g. abnormal sounds, smells, smoke), immediately shut the power off. After checking to see that the abnormal condition does not continue, call our authorized distributor in your region.
- If the display reading changes between the steps, turn the POWER switch off then on again. If the problem continues, turn the power switch off and call our authorized distributor in your region.

How to Read this Manual

- This operation manual consists of the following sections covering the information required for proper operation of the Autoclave HVA-85/110:

Chapter 1. What is the Autoclave HVA-85/110?

This section describes the uses and features of the product, and the names and functions of its parts.

Chapter 2. Installation

This section explains where the equipment should be installed and how to install it. The product incorporates precision parts, so be sure to follow the instructions covered in this chapter.

Chapter 3. Operation Method

This section illustrates how to change various set values, and describes operations before starting the equipment and after automatic operation. This section also covers the display and performance of the equipment during automatic operation.

Chapter 4. Maintenance and Service

This section explains the methods for draining water from the exhaust bottle or chamber, servicing the body of the equipment, and parts replacement.

Chapter 5. Specifications

This section includes dimensions, power consumption and working range of the product. Refer to this section as required.

Chapter 6. Troubleshooting

This section covers troubleshooting procedures for the product. If you encounter a problem, read this section first.

Appendix

This section contains information on the warranty and a glossary of terms that appear in the manual. Refer to this section when necessary.

Contents

Introduction	1
Read Carefully Before Using	2
How to Read this Manual	4
Contents	5
Chapter 1. What is the Autoclave HVA-85/110	6
1. Product Uses	6
2. Product Features	6
3. Names and Functions of Parts	6
Chapter 2. Installation	8
1. Installation Instructions	8
2. Installation Procedure	9
Chapter 3. Operation Method	12
1. Power On	13
2. Pouring Water	13
3. Loading Substance	14
4. Selecting Mode (Process)	15
5. Changing Set Values (Registering of Values by Customer)	17
6. Starting Operation	19
7. Unloading	20
8. After Completion of Operation	21
9. Canceling Operation	21
10. When Power Supply Is Cut during Operation	21
11. Operation of Cycles	22
Chapter 4. Maintenance and Service	25
1. Draining Exhaust Bottle	25
2. Draining Chamber	26
3. Cleaning Chamber	26
4. Cleaning Body	27
Chapter 5. Specifications	28
Chapter 6. Troubleshooting	29
1. Error Detection (Alarms)	29
2. Early Troubleshooting	31
Appendix	32
1. Limited Warranty	32
2. Fast wearing Parts	32
3. Glossary	32

Chapter 1. What is the Autoclave HVA-85/110?

1. Product Uses

- The product is used to sterilize substances that can withstand high temperature and/or high pressure steam: there include tools of glass, ceramic, metal or rubber, water, media, reagents, and liquid medicines.

2. Product Features

- The product is equipped with a lid cover to protect personnel from the high temperatures reached by the lid during use.
- The product is provided with a sterilization-warming mode to prevent coagulation of sterilized media that are not immediately removed from the Autoclave chamber.
- The product can execute the cooling down automatically after sterilization by setting the cooling pattern.

3. Names and Functions of Parts

Outer View of Body

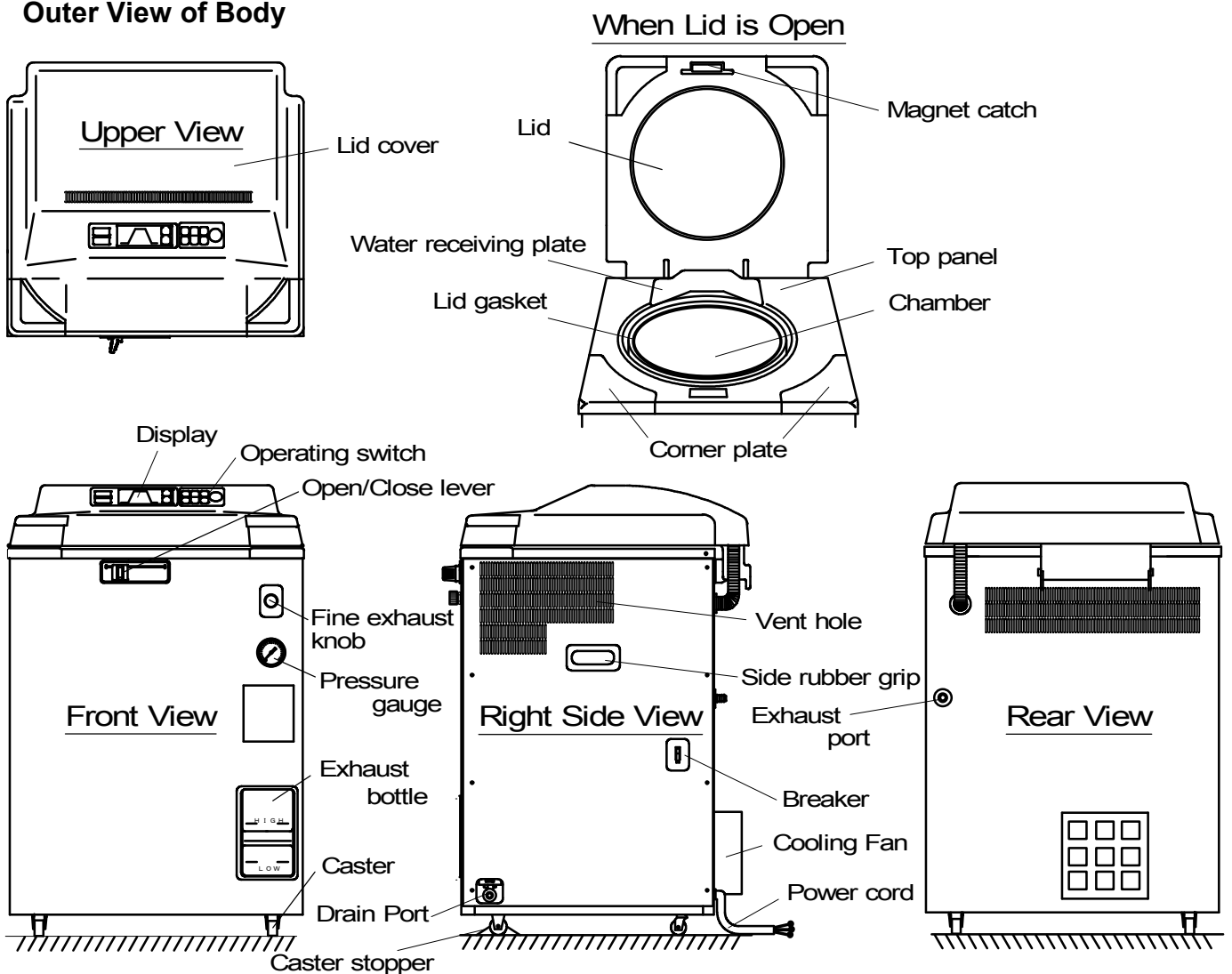

Display and Operation Switches

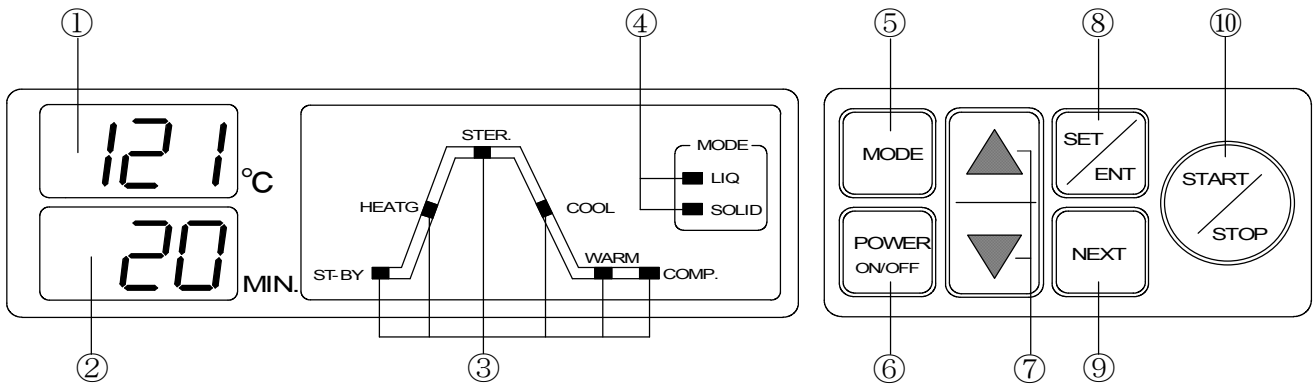

- ① **Digital Display (Temperature, Error)**
The digital display indicates the set temperature when the equipment is in standby and the temperature in the working chamber during operation. When a problem occurs and an error is detected, the display indicates the error.
- ② **Digital Display (Time, Cooling Pattern)**
The digital display indicates the set time and the set cooling pattern when the equipment is in standby and the time remaining before completion of sterilization during operation.
- ③ **Cycle Display (ST-BY, HEATG, STER., COOL., WARM, COMP.)**
All the steps included in the selected mode illuminate and the current step flashes.
- ④ **Mode Display (LIQ, SOLID)**
The operation/action of the selected mode lights.
- ⑤ **MODE Switch**
Selects a mode or checks a set temperature, time, or exhaust pattern.
- ⑥ **POWER ON/OFF Switch**
Turns the power on or off.
- ⑦ **Set Value Increase/Decrease Switches (▲, ▼)**
Increase or decrease the set values.
- ⑧ **SET/ENT Switch**
Used to change a set value.
- ⑨ **NEXT Switch**
Selects the item for which the setting will be changed.
- ⑩ **START/STOP Switch**
Used to start or stop operation.

Chapter 2. Installation

! IMPORTANT :

- If the equipment is installed in a place which is 800m or higher than sea level (i.e. under low pressure in mountainous areas), the settings must be changed. In this case, be sure to contact our authorized distributor in your region. Do not use the equipment before changing.
- When transporting the equipment, close the lid and slide the open/close lever to **LOCK** side (left end) to prevent the lid from opening.
- When moving the lid, do not hold it by the handle, otherwise the lid may become difficult to close.

1. Installation instructions

- ① Avoid installing the equipment in a place where its body may be exposed to water or chemicals, or where corrosive and explosive gases may be produced nearby.
- ② Avoid installing the equipment in a place which is exposed to high humidity, direct sunlight or much dust.

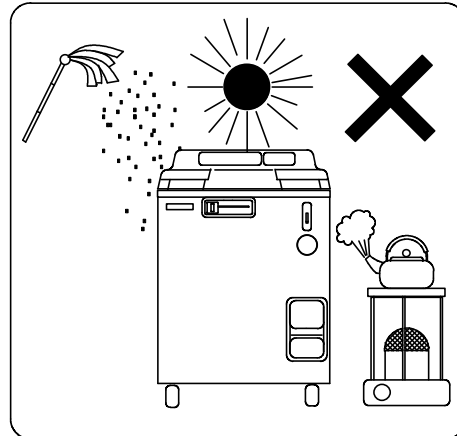
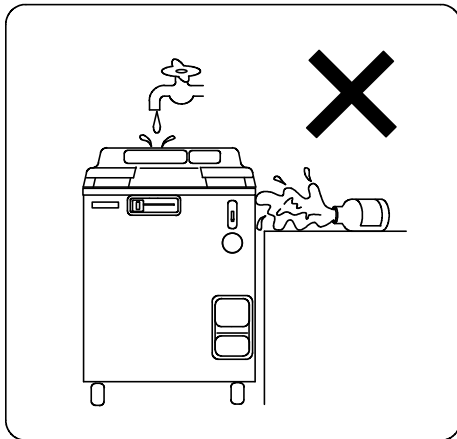

- ③ Avoid placing the equipment directly under a fire detector. If you open the lid immediately after completion of operation, steam comes out of the working chamber, and may activate the detector.
- ④ Arrange the equipment with a clearance of 10 cm or wider on the right side and 12 cm or wider on the rear side to prevent the vent hole from being blocked.

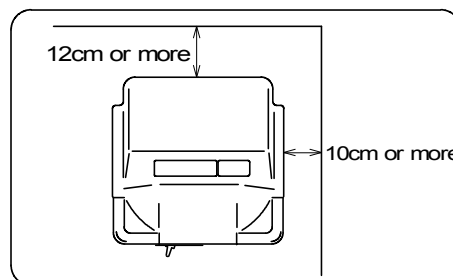
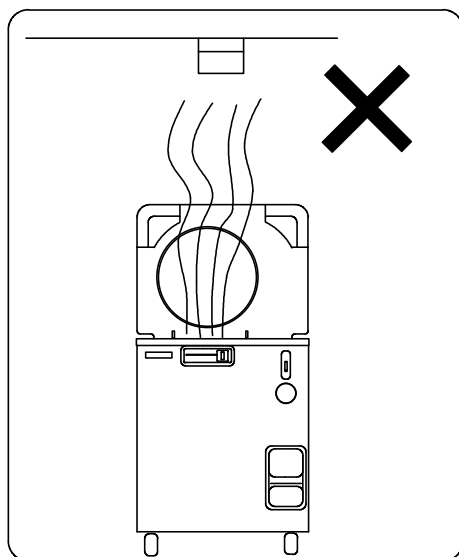

- ⑤ Avoid installing the equipment with its rear side located near outlets or electrical appliances as steam comes out of the exhaust port on the rear.
- ⑥ Avoid an installation place which is subject to impact or vibration.
- ⑦ Avoid outdoor usage.
- ⑧ Place the unit in a level, firm place.
- ⑨ Avoid installing in a place which is subjected to a room temperature of 5 °C or below or 35 °C or above.

2. Installation Procedure

- Put the body on the caster stoppers to prevent it from accidentally moving.
Anchor the body as described in the following.

(1) Set the stopper the specified distance from walls.

Specified distance L = **HVA-85/110**..... 67 cm or more

(2) Push the body until the front casters roll onto the stopper

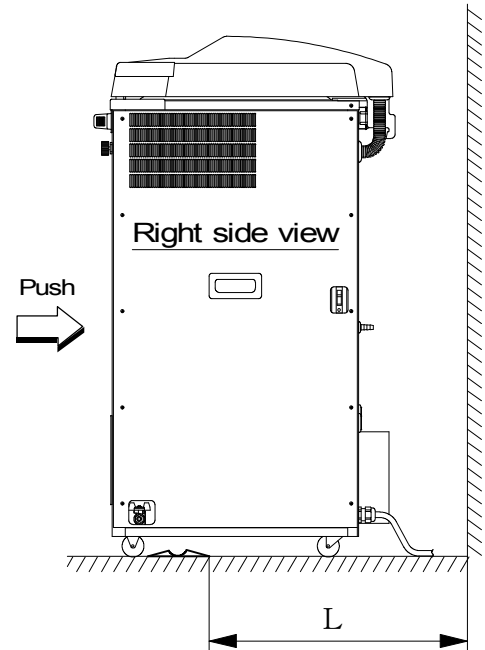

- Connect the power cord to a rated power supply.
 - Reliably ground the grounding cable.

WARNING:

- Do not forcibly bend, twist, tie, or extend the power cord. Do not place heavy objects on the cord. A damaged cord or exposed wire may cause fire or electric shock.
- Never connect the power cord to a power supply with a voltage other than the rated voltage. Connection to such a power supply may cause fire or electric shock.
- If not plugging the sterilizer into a grounded socket, ground the equipment separately before connecting it to the power source.
- Never ground to a gas pipe or vinyl chloride water service pipe.

CONNECT TO RATED VOLTAGE

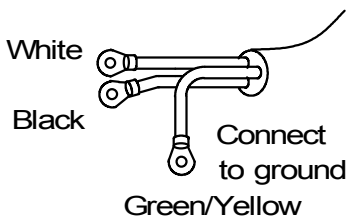

Model	AC220V	AC230V	AC240V
HVA-85	14A or more	13A or more	13A or more
HVA-110	19A or more	18A or more	17A or more

③ Pour water into the exhaust bottle.

- Add water to the exhaust bottle as described below.

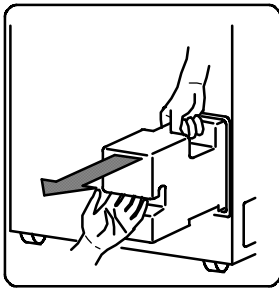

(1) Unload the exhaust bottle from the body.

- Pull the bottle outwards until the top handle can be grabbed securely. Lift the bottle out of the autoclave using this handle.

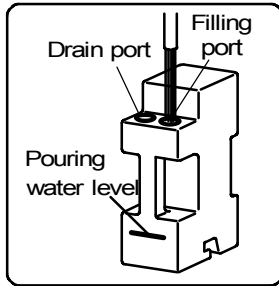

(2) Pour water into the bottle through the water filling port. Fill water to the reference line level.

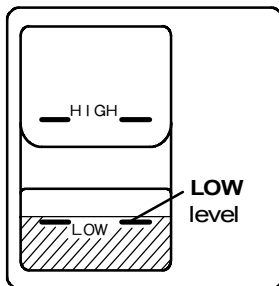

(3) Check to make sure that the water level is at **LOW** level (the lowest water level).

- If too much water has been poured in, then place the bottle in a level sink with the side of the water filling and drain ports facing downwards. Any excessive water is drained automatically until the water level is lowered to the **LOW** level.

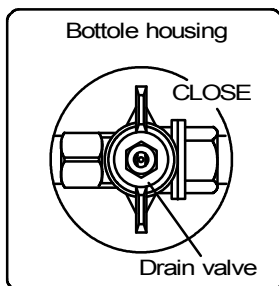
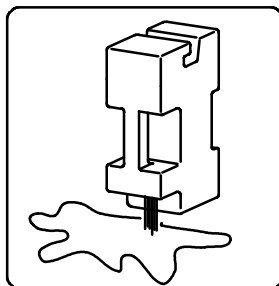

(4) Check to see that the drain valve, located at the bottom of the exhaust bottle housing area, is closed.

(5) Load the bottle into the area.

- Be sure to push the bottle to the end, or else an error (**E r E**) will occur.

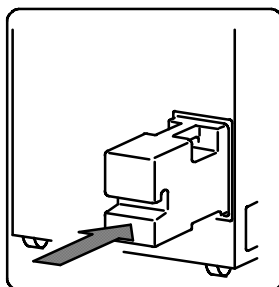

④ Turn the breaker ON.

Lift the circuit breaker lever on the right side of the main body.

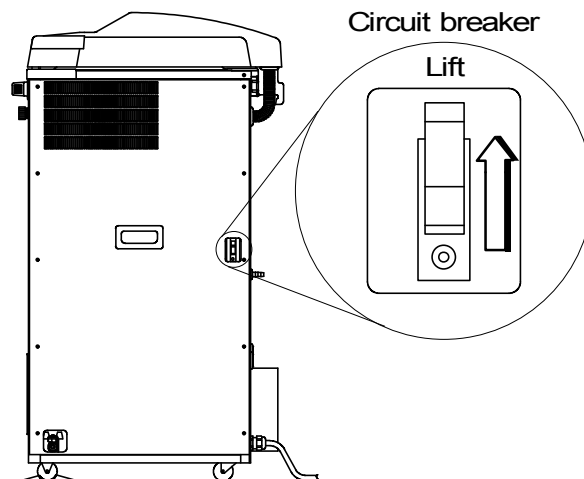

⑤ Referring to “**Chapter 3, Operation Method**”, open the lid and take out the accessories.

⑥ Place the bottom plate in the chamber.

⑦ Steam is apt to emit from the exhaust port located at the rear of the body.

Therefore, install the exhaust hose and the drain bottle in the following manner:

(1) Attach the strap and clamp loosely in use of the screw attached to the body.

(2) Pass the exhaust hose through the strap. Be careful not to clog the hose by folding.

(3) Put the hose tip about 5cm into the drain bottle, and tighten the strap.

[N.B.] Pour out the water from the drain bottle so that the hose tip does not touch the water.

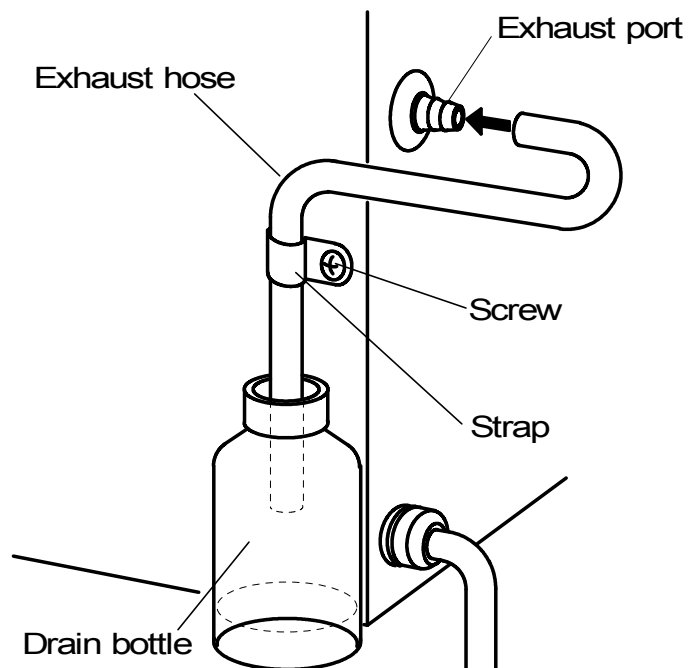

Chapter 3. Operation Method

Basic Operation Method

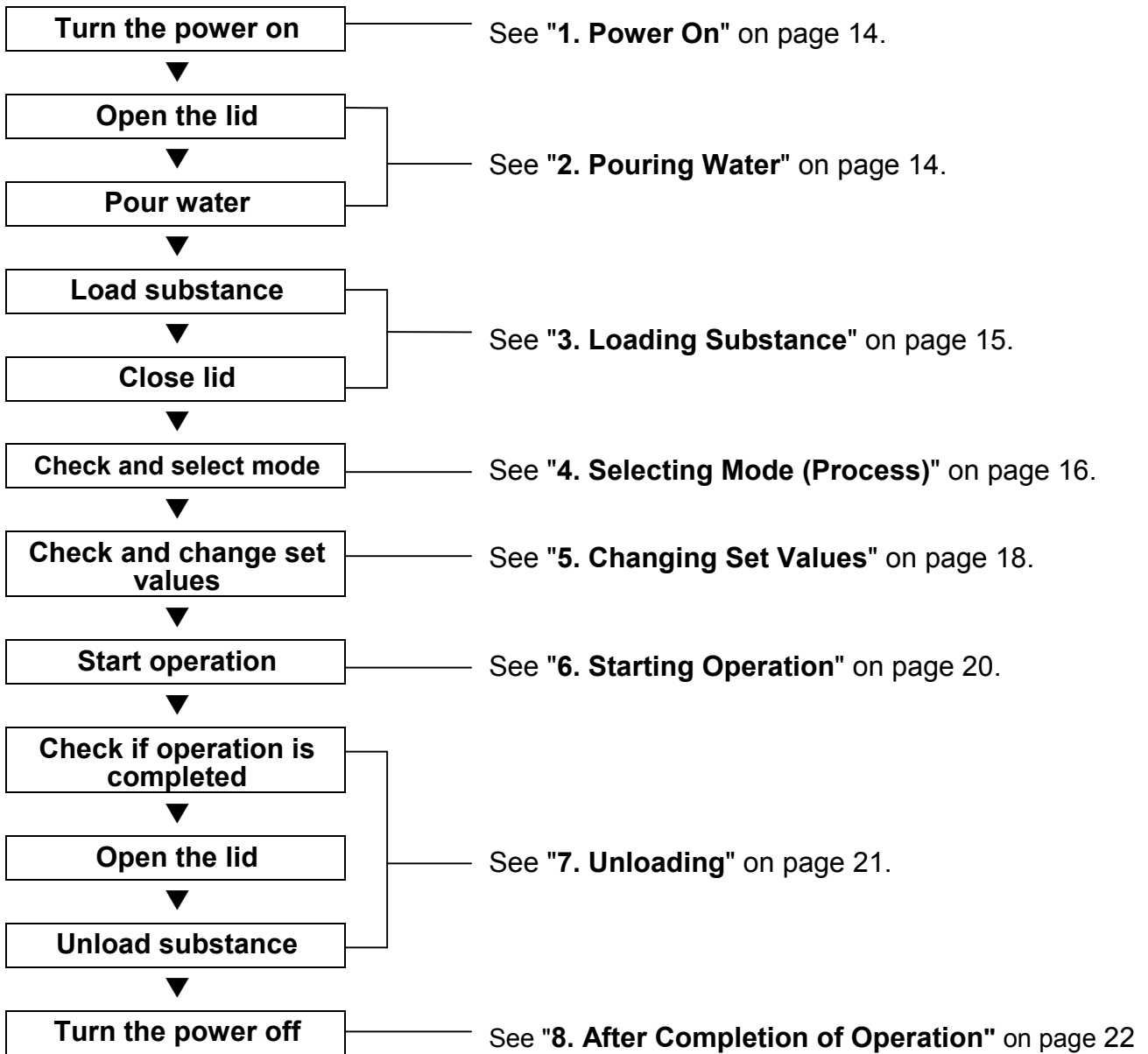

1. Power On

- Press the POWER ON/OFF switch at the front of the body.
When the open/close lever is set to “**LOCK**” (left side), Mode number is indicated on the display. After 2 seconds, the display indication changes into setting values, and the autoclave is ready in this state. When the open/close lever is set to “**UNLOCK**” (anywhere other than on the left side), “Lid” and “Temperature in the working chamber” are shown alternately on the display.

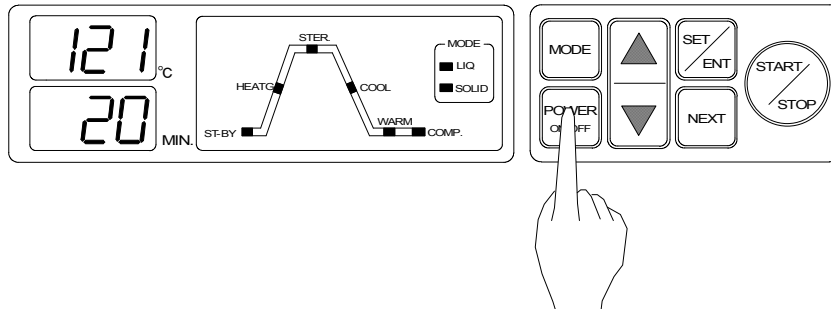

NOTE:

- If the operation switches and the lock / unlock lever are left un-operated for **30 minutes**, the power saving function starts to work so that the display board blackens except for dots blinking at the temperature zone. For reviving the display, please press any of the operation switches.

2. Pouring Water

CAUTION:

- Do not pour anything except for water.
- Raise the lid slowly. When an impact is added to the lid, there is fear which the hinge of the lid damages.

IMPORTANT:

- In operation of **UNLOCK/LOCK** lever, never fail to put **POWER** switch **ON**.

- Slide the open/close lever to the **UNLOCK** side (right end).
- Grab the handle and lift the lid as shown in the figure below.
- Pour water through the opening of the chamber until you can see water through the hole at the center of the Heater cover.
 - The **HVA-85** requires **4 liters** and **HVA-110** requires **5 liters** of water.

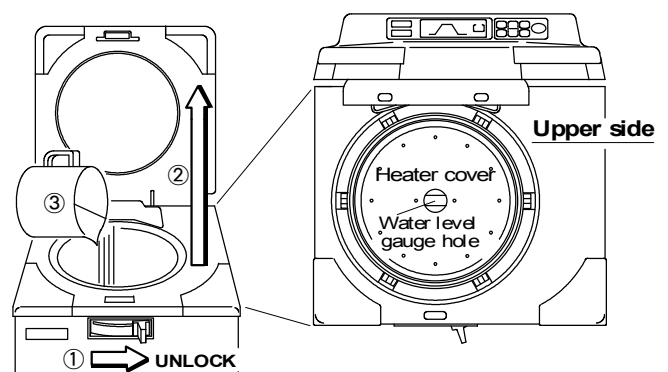

3. Loading Substance

! CAUTION:

- Be careful not to pinch hands when closing the lid.
- Close the lid after confirming that no foreign matter is adhering to the section contacting the lid gasket. Foreign matter in this section may cause vapor leaks.
- When using a waste processing bag or other kind of bag and disinfecting, place the bag in the metal mesh holder and insert it into the working chamber. Using the bag “as is” can cause excessive temperatures, pressures, lack-of -water, etc.

! IMPORTANT :

- Check to see that the temperature in the chamber is 50°C or below before starting the next operation (operating the open/close lever).
- Be sure to use the Heater cover.

- ① Place the substance to be sterilized into the chamber.
- ② While having the handles, lid down the lid.
- ③ Press the front-center portion of the lid down until the magnet catch is attracted to the magnet.
- ④ While pressing the lid, slide the open/close lever to the **LOCK** side (the left end).

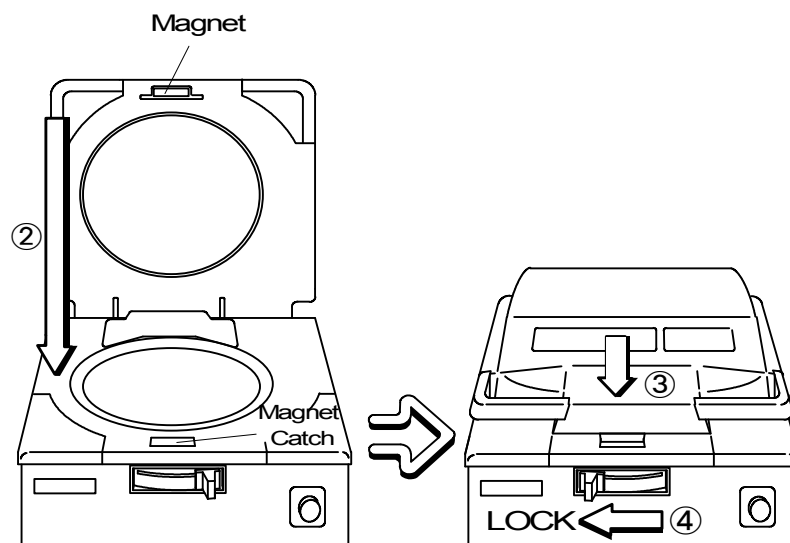

NOTE:

- When sterilizing an empty deep container, lay the container on its side in the chamber so that it will be permeated with steam. An upright position may cause insufficient sterilization.
- If a waste disposal bag is used in sterilization, open the bag far enough that the bag is not in contact with the inside surface of the chamber. Insufficient sterilization may be caused if the bag is closed during sterilization. When the bag is opened excessively, steam is prevented from circulating in the chamber. This may also result in insufficient sterilization.
- Do not pile specimens on top of one another. When the chamber is overly packed, steam fails to penetrate to all points, resulting in incomplete sterilization.
- In sterilizing liquids such as chemicals and media, pay attention to the quantity of the liquid in relation to its container. For an Erlenmeyer flask, the amount of chemical should be approx. 3/4 of the capacity of the container; for a test tube, the appropriate quantity of chemical is approx. half of the capacity of the container. Too much chemical may result in overflow from the container during the temperature rising or cooling process.
- Use container caps that are loose fitting and allow the passage of air. Containers may break if venting is not possible.
- Use the DURHAM TEST TUBE (Sample tube) with 6mm caliber or more. At the DURHAM TEST TUBE (Sample tube) with less than 6 mm caliber, air bubble sometimes remains.

4. Selecting Mode (Process)

- The following modes are programmed in the microcomputer. Select an appropriate mode.

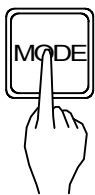

- ① Press the **MODE** switch.
Each time the switch is pressed, the current mode repeatedly changes from Mode 1 to Mode 2, 3, 1... in sequence.
After 2 seconds of Mode number indication, the setting values are displayed.

Mode	Application
1	Sterilization of agar medium (warmed for the prevention of coagulation after sterilization).
2	Sterilization of liquids, such as water, media, reagents, and liquid medicines, that withstand high temperature, high pressure steam.
3	Sterilization of tools of glass, ceramic, metal or rubber that withstand high temperature, high pressure steam and abrupt depressurization during the exhaust process.

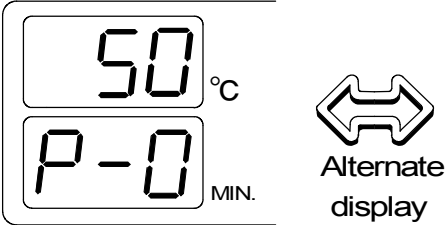
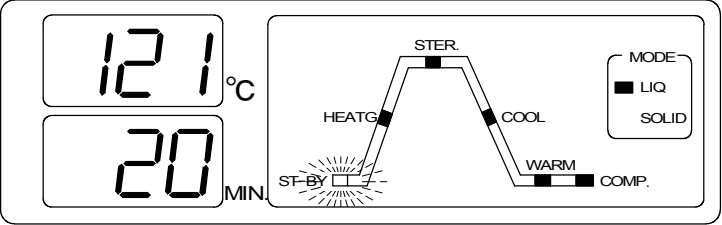
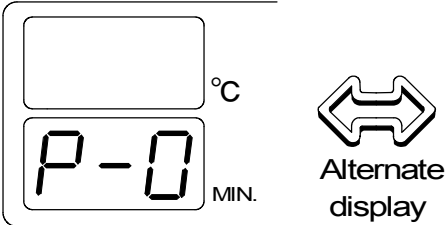
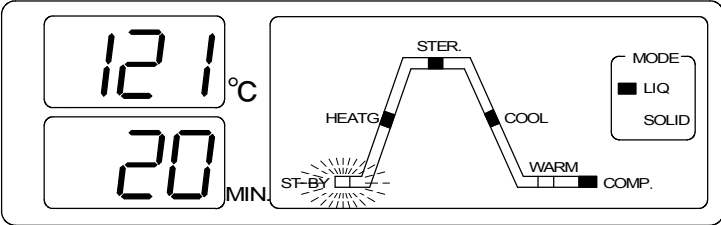
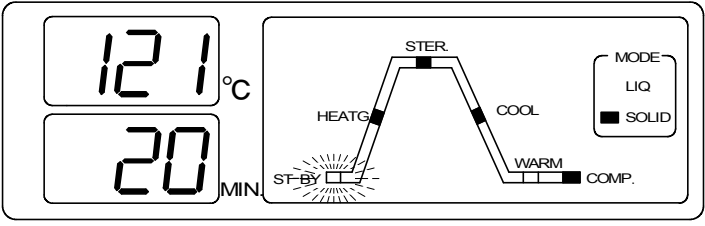
	Step Display	Initial Value				Mode Display
		Sterilization Temperature	Sterilization Time	Warming Temperature	Cooling pattern	
Mode 1	HEATG → STER. → COOL → WARM	121°C	20 minutes	50°C	P - 0	LIQ
1						
Mode 2	HEATG → STER. → COOL	121°C	20 minutes	—	P - 0	LIQ
2						
Mode 3	HEATG → STER. → COOL	121°C	20 minutes	—	—	SOLID
3						

5. Changing Set Values (Registering of Values by Customer)

- Follow the steps below to change set values (sterilization temperature, sterilization time, warming temperature, and exhaust pattern). Settings cannot be changed during operation (after starting).

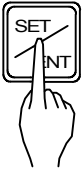

- ① Press the **SET/ENT** switch.

- The display of the set sterilization temperature will blink indicating that the value is now changeable.



- ② Press the **NEXT** switch to select an item to change.

- Each time the switch is pressed, the item to set will change in the sequence shown below.

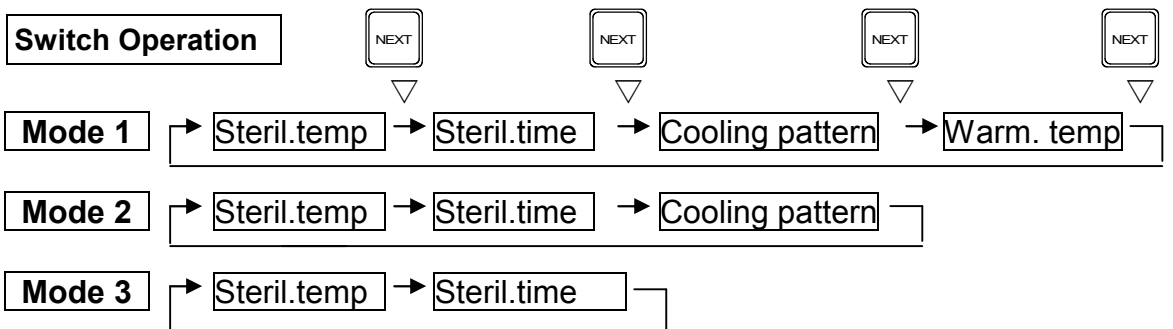
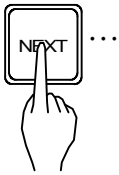

- ③ Change the displayed value using the setting increase/decrease switches (▲, ▼).

- Each time the switches are pressed, the displayed value increases or decreases as follows:



Sterilization temperature: (In increments of 1°C within a range of:)

HVA-85/110 : 105~135°C

Sterilization time : 1 minute increments within a range of 1 - 250 minutes

Cooling pattern : Units of 1 within a range of 0 - 2

Warming temperature: 1°C increments within a range of 45 - 80°C

- If a switch is held down, the displayed value increases or decreases in 10 unit increments. When the displayed value exceeds the upper limit (lower limit), it returns to the lower limit (upper limit).



- ④ Press the **SET/ENT** switch.

- The changed value is stored and the display stops blinking and lights up. This completes the setting operation.

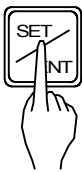

Canceling Setting Value Changes

- To cancel setting changes during the change operation, press the **MODE** switch. The changed values will not be stored and the equipment will return to the standby state.

NOTE:

- For sterilization of liquids, set a sterilization time longer than desired, taking a delay time into account according to the table below.

Example)

When there is 3 liters of water in a flask, it takes nearly 30 minutes (delay time) for the temperature of the water to reach a set sterilization temperature after the temperature in the chamber reaches the set value. The sterilization time should therefore be set 30 minutes longer than desired in order to deal with this time delay. The sterilization time is therefore set at 50 minutes.

Set sterilization time (50 minutes)
 = *Delay time (30 minutes) + desired sterilization time (20 minutes)*

HVA-85 Reference Values of Delay Time (per flask)

Liquid Volume	Delay Time
3 liters	30 minutes
2 liters	20 minutes
1 liter	10 minutes
500cc	7 minutes

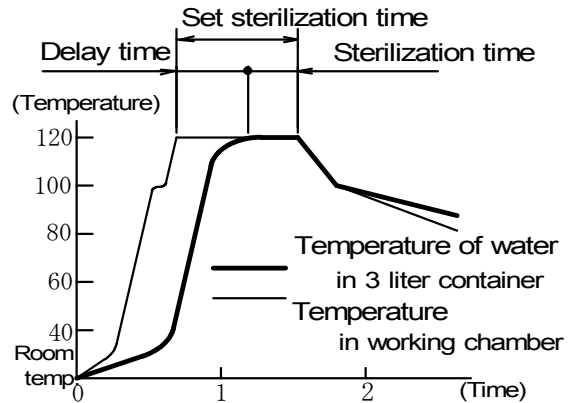

Delay Time Reference Data

- If steam is abruptly exhausted after sterilization of a liquid, the liquid may gush out. To prevent this, change the exhaust pattern setting depending on the container. When purging manually using the fine exhaust knob, change the setting to P-0.

- P-0: Cooling is not executed and equipment is left to sit. (Natural Cooling)
- P-1: Pulse Cooling is executed (Cooling Fan 50 % works).
- P-2: Cooling is executed (Cooling Fan 100 % works).

- The mode, temperature, time, and cooling pattern are memorized even if the power is cut off by the **POWER ON/OFF** switch. When the power is cut by the breaker, a power outage, or a temporary loss of power, the settings will return to the initial settings of mode 1. Reset the setting values as desired when this occurs.

6. Starting Operation

- ① Ascertain that the water level in the exhaust bottle is between the **HIGH** and **LOW** levels.

If above the **HIGH** level: See "**1. Draining Exhaust Bottle**" on page 26.

If below the **LOW** level: See "**2. Installation Procedure (3)**" on page 10.

- ② Ascertain that the water level in the drain bottle is low enough not to touch the tip of the exhaust hose.
[N.B.] Pour out the water from the drain bottle so that the hose tip does not touch the water.

- ③ Confirm that the fine exhaust knob is closed.



Fine exhaust knob



- ④ Press the **START/STOP** switch

- The open/close lever is locked and the lid can not be opened.

Thereafter, one of the following processes is executed depending on the

chosen mode of operation. For details on each specific mode, see "**11 Operation of Cycles**" on page 23.

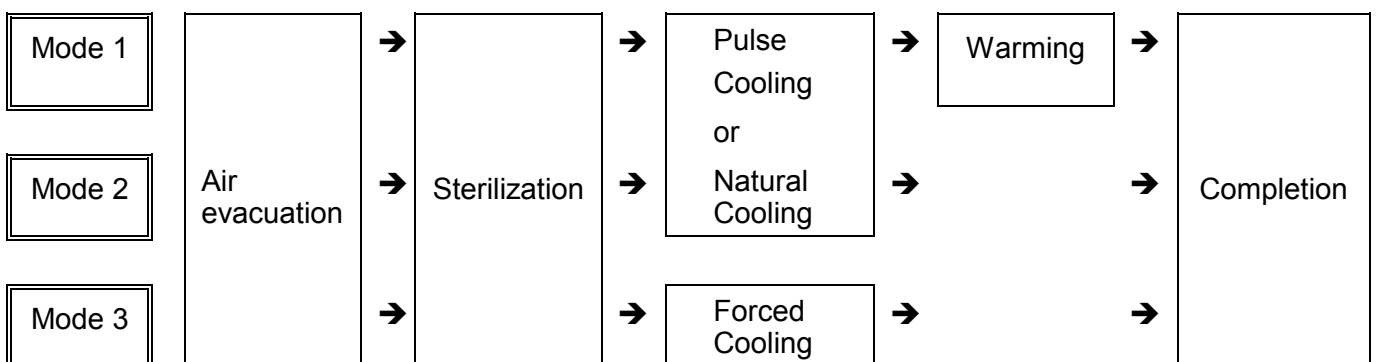

Checking the Set Values during Operation

- To check the set values for temperature, time, or cooling pattern during operation, press the **MODE** switch. The set value remains on the display while the switch is held down. Set values are not changeable.

7. Unloading

WARNING:

- Confirm that the gauge for pressure in the chamber reads "0MPa".

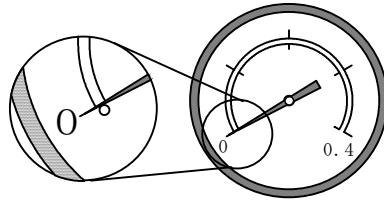

Pressure gauge

CAUTION:

- Keep the face and hands away from the chamber when lifting the lid after operation is complete; steam will gush out of the opening of the chamber.
- When operation is complete, the lid, chamber and panel are hot. To prevent burns, do not touch these areas with bare hands.
- A long time is required for a liquid to cool. Be sure to check that the temperature has dropped sufficiently before unloading a liquid from the chamber or a burn may result.
- Put on heat insulation gloves before removing a substance from the chamber. Do not put hands into the chamber until the steam has been vented.

- ① Slide the open/close lever to the **UNLOCK** side (to right end).
- ② Lift the lid
- ③ Take the sterilized substance out of the chamber.

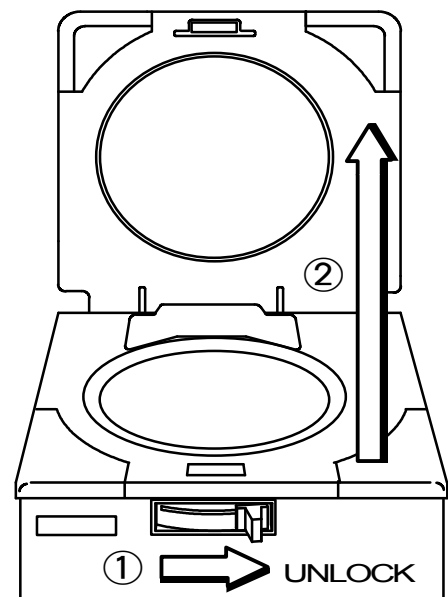

8. After Completion of Operation

- ① Turn off the power switch after the completion of daily operations.
- ② If the fine exhaust knob is open, turn it until closed.

! **IMPORTANT :**

- To prevent clogging of the piping, refer to "**Draining Chamber**" and change the water within the chamber once per day.

9. Canceling Operation

- ① Press the **START/STOP** switch



- The process currently being executed will be interrupted and the equipment will return to the standby state (state before operation).
- When removing the sterilized substance from the chamber, follow the instructions described in "**7. Unloading.**" (When the chamber temperature drops below 97°C, the pressure drops to 0MPa. In this state, the open/close lever is unlocked.)

10. When power supply is shut off during operation

- If power supply is shut off before completing the operation due to power failure etc, operation is interrupted and the power switch is in the off state when power supply comes back.

When the POWER switch is pressed and the equipment becomes standby state, $E r \square$ is displayed in the digital display window and an electronic alarm sounds to notify it that the operation was not completed due to the power failure. This power failure notice is stored in memory and it continues to notify even if the ON /OFF operation of the POWER switch is repeated.

When the START/STOP switch is pressed during the power failure notice, the display turns to the standby state (the state before operation startup). Redo the operation once again.

△ **NOTE :**

- If the power supply is cut due to power failure or other problem, the open/close lever is locked for safety. To open or close the lid, follow the instructions described in "**7. Unloading**" on page 21 after the power supply has been restored.

11. Operation of Cycles

■ Air Evacuation Cycle --- Common to all modes

- The **ST-BY** display stops flashing and lights up and the **HEATG** display starts blinking. The temperature in the chamber is displayed in the digital temperature display section.
- Any air remaining in the working chamber makes the temperature distribution in the chamber uneven. This hinders temperature increases (sterilization). To deal with this problem, a microcomputer-controlled automatic exhaust valve vents virtually 100% of the air.
- Temperature increases until the set sterilization temperature (pressure) is reached.
- After the set sterilization temperature is attained, the **HEATG** display stops flashing and lights up. Operation then proceeds to the next cycle.

■ Sterilization Cycle --- Common to all modes

- The **STER.** display goes out and starts blinking. The set sterilization time is shown in the digital display upon activation of the sterilization timer.
- A constant temperature (pressure) is maintained during the set sterilization time period.
- If the temperature in the chamber drops 1°C or more from the set value due to any trouble, the temp. over-drop mark appears on the digital display, and the digital timer operation is interrupted. When the set temperature is regained, the timer restarts operation.
- The digital timer displays the remaining time during the sterilization cycle. Refer to "**Checking Set Values during Operation**" on page 18 for the method of checking the set time during operation.
- When the preset sterilization time has passed, the **STER.** display stops blinking and lights up, and operation proceeds to the next cycle.

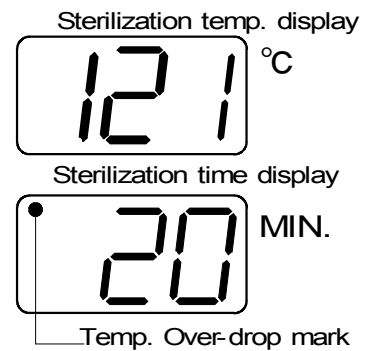

△ **NOTE:**

- In sterilization of petri dishes or empty containers, the air remaining in the container expands and may increase the pressure remarkably within the chamber. If the pressure in the chamber exceeds the saturated steam pressure, the automatic exhaust valve opens and discharges the air in the chamber into the exhaust bottle.
- The chamber temperature is somewhat high to prevent the internal temperature from falling below the sterilization setting temperature.

■ Cooling Cycle --- Modes 1 and 2

- The **COOL** display will start to flash.
- When the cooling pattern is set to P-1, the cooling fan independently and pulse cooling is executed. When the exhaust pattern is set to P-2, Forced Cooling is executed. When P-0, the cooling fan does not work the chamber cools naturally.

△ **NOTE :**

- If steam is abruptly exhausted after sterilization of a liquid, the liquid may gush out. To prevent this, change the cooling pattern setting depending on the container. When purging manually using the fine exhaust knob, change the setting to P-0.

P-0: Cooling is not executed and equipment is left to sit. (Natural Cooling)

P-1: Pulse Cooling is executed (Cooling Fan 50 % works)

P-2: Forced Cooling is executed (Cooling Fan 100 % works)

- When the chamber temperature falls below 79°C, the **COL** display stops blinking and lights up. Operation then proceeds to the next cycle.

■ Forced Cooling Cycle --- Mode 3

- The **COOL** display flashes and the Cooling Fan start to work.
- When the temperature in the chamber falls below 97°C the **COOL** stops blinking and lights up. Operation then proceeds to the next cycle.

■ Warming Cycle --- Mode 1

- The **WARM** display starts blinking.
- When the temperature in the chamber falls to the set incubation temperature, the electronic alarm gives a beeping sound.
- When 20 hours (fixed) has elapsed after the temperature dropped to the set incubation temperature, the **WARM** display stops flashing and lights up. Operation then proceeds to the next cycle.

△ **NOTE :**

- After the warming time (20 hours) has elapsed, the chamber is not heated; temperature in the chamber falls to room temperature, and the remaining agar medium, if any, in the chamber will coagulate.
- When removing a sterilized substance from the chamber during the warming cycle, press the **START/STOP** switch to stop operation. Refer to "**7. Unloading**" on page 21 for further operations.

■ **Completion Cycle --- Common to all modes**

- When all cycles of a mode are complete, the electronic alarm indicates the completion by beeping 3 times. The **COMP** display then starts blinking.

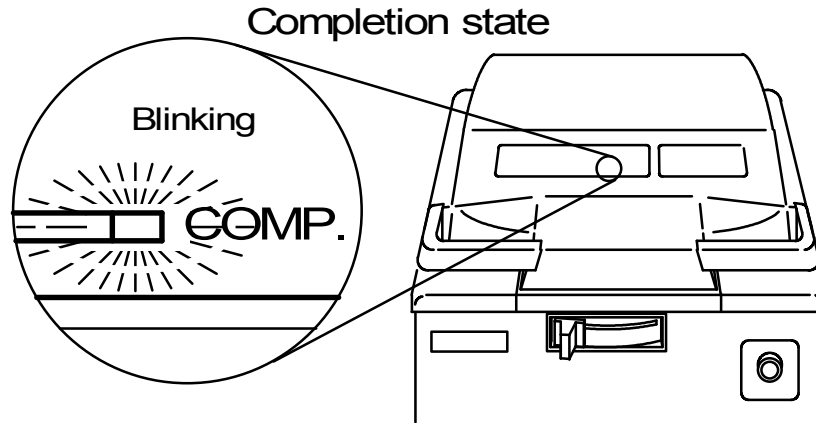

NOTE:

- If the operation switches and the lock / unlock lever are left un-operated for 30 minutes, the power saving function starts to work so that the display board blackens except for dots blinking at the temperature zone. For reviving the display, please press any of the operation switches.

Chapter 4. Maintenance and Service

! **WARNING:**

- Be sure to start maintenance or service work after the main body has been sufficiently cooled.

1. Draining Exhaust Bottle

Water collects in the exhaust bottle as operations are repeated. If the water is above the **HIGH** level (allowable highest water level), drain the bottle in accordance with the following procedures.

! **CAUTION:**

- Do not unload the exhaust bottle before water in the bottle has been sufficiently cooled.

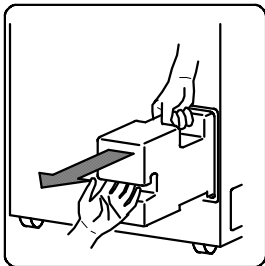

① Remove the exhaust bottle from the body.

- Pull the bottle outward until the top handle can be grabbed securely.

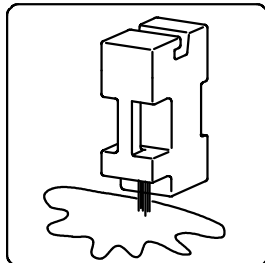

② Place the bottle in a level sink with the water filling and drain ports facing downwards.

- Excessive water is drained automatically until the water level is lowered to the **LOW** level (lowest allowable water level).

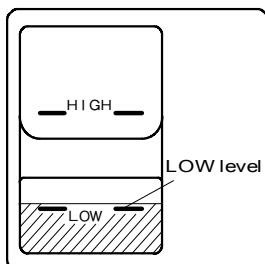

③ Be sure that the water level is at **LOW** level.

- Ensure that water is left at the **LOW** level (lowest allowable level), which is required for sufficiently cooling the steam.

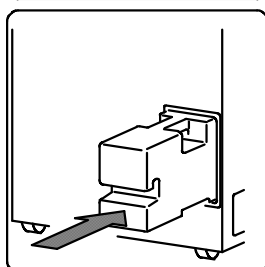

④ Loading the exhaust bottle into the bottle housing area.

- Be sure to push the bottle to the end, or else an error (**ErE**) will occur.

2. Draining Chamber

- When planning to put the equipment out of service for a long time, be sure to drain the chamber to prevent pipe clogging. After checking that the chamber has been sufficiently cooled, drain the chamber in accordance with the following procedure.

! CAUTION :

- Do not unload the exhaust bottle or drain the chamber when the chamber is under pressure. Boiling water or steam may gush out causing burns.

- ① Open the lid.
- ② Connect one end of the attached drain hose to the tap of the drain valve located at the lower part of the right side of the body.
- ③ Put the other end of the hose in a container.
- ④ Remove the exhaust bottle from the body.
- ⑤ Turn the drain valve knob, located at the bottom of the exhaust bottle housing area, counterclockwise to open.
- ⑥ Check if draining of the chamber is complete.
- ⑦ Turn the knob clockwise to close the drain valve.
 - Be sure the exhaust valve is closed.

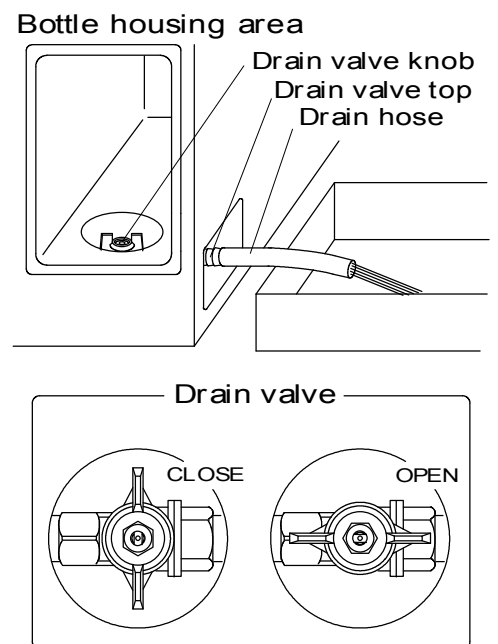

3. Cleaning Chamber

! CAUTION :

- The heater is provided with a temperature sensor, be careful not to damage this sensor when cleaning.

- ① Take out the bottom plate to see if the bottom of the chamber or the surface of the heater is dirty. After draining the chamber, clean these areas with a soft brush or other tool while applying water and keeping the drain valve open.
- ② If the temperature sensor comes loose from the fixing clip, reattach it.

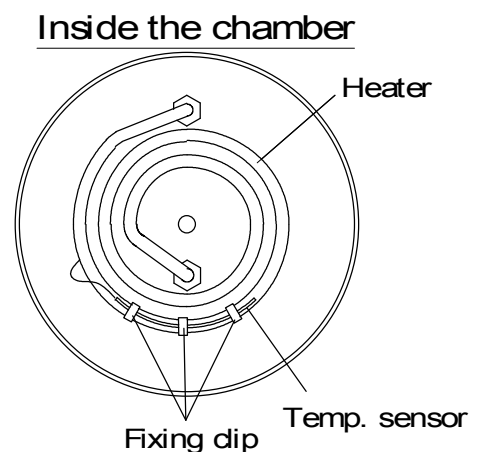

4. Cleaning Body



IMPORTANT :

- Do not use benzine or thinner to clean the body. Also make sure that the volatile substances such as insecticides do not come into contact with the body as these substances may deteriorate the body or strip its paint.
- ① Gently wipe stains from the body with a soft cloth. To remove stubborn stains, wring a cloth moistened with neutral detergent diluted with water, and wipe off the stains with it. Wipe off any moisture with a dry cloth.
 - ② The fan for the cooling has been attached to the rear face on the main body. Please do the cleaning of the stitch surface with cleaner etc. in a year, or that cooling time became long.

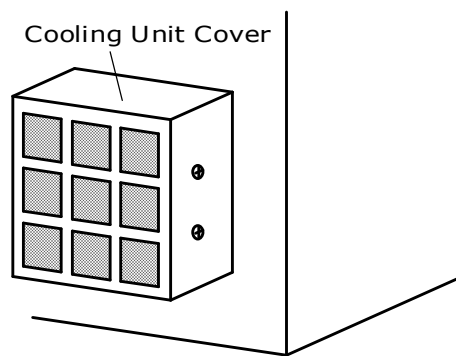

Chapter 5. Specifications

Model	HVA-85	HVA-110
External dimensions	667W × 1011H × 652 D mm	667W × 1191H × 652 D mm
	(D size is not including Open/Close & Fine Exhaust Knobs)	
Internal dimensions	420Ø × 615D mm (Effective: 85 liter)	420Ø × 795D mm (Effective: 110 liter)
Rating Power source	AC220V ± 10% Single-phase 50/60Hz(14A or more) AC230V ± 10% Single-phase 50/60Hz(14A or more) AC240V ± 10% Single-phase 50/60Hz(13A or more)	AC220V ± 10% Single-phase 50/60Hz(19A or more) AC230V ± 10% Single-phase 50/60Hz(18A or more) AC240V ± 10% Single-phase 50/60Hz(17A or more)
Temperature and humidity conditions	5~35°C, 10~85%RH (Subject to, no condensation)	
Power consumption	3.0KW (220V=13.6A, 230V=13.1A, 240V=12.5A)	4.0KW (220V=18.2A, 230V=07.4A, 240V=16.7A)
Net Weight (approx.)	78kg	85kg
Pressure vessel type	Small sized pressure vessel	
Chamber material	Stainless Steel (SUS304)	
Sterilization temperature range	105 ~ 135°C variable	
Sterilization timer	1~250 minutes, remaining time displayed	
Warming temp. range	45 ~ 80°C variable	
Cooling pattern setting	3 patterns (including Natural Cooling)	
Max. operating pressure	0.255MPa	
Thermometer	Digital display, 5 ~ 137°C	
Pressure gauge	Analog display, 0 ~ 0.4MPa	
Safety devices/ Warning alarm	Pressure safety valve, Circuit breaker, Lack-of-water prevention device, Error display (Lack-of-water, Temperature sensor wire breakage, Over temperature, Over cooling, Excess pressure, Open/close lever locking failure)	
Accessories	Wire basket (2 pcs) Exhaust bottle (1 pc) Bottom plate (1 pc) Drain hose 50 cm (1 pc) Exhaust hose 50 cm (1 pc) Drain bottle (1 pc) Strap (1 pc) Operation manual (1 pc)	

Chapter 6. Troubleshooting

1. Error Detection (Alarms)

Should any malfunction occur in the autoclave, the error detection circuit will be triggered to assure safety. Once the circuit is activated, an error number appears on the digital display and the electronic alarm sounds, indicating the problem. To stop the alarm sound, press the START/STOP switch. If an alarm occurs, check the error number and turn off the power switch.

Error Number	Problem	Remedy
E r 1 (Lack-of-water alarm)	<ul style="list-style-type: none"> Lack-of-water 	<ul style="list-style-type: none"> Check to see that the pressure is at "0MPa" and then open the lid. After the heater has been cooled, pour in a sufficient quantity of water, and repeat operations from the beginning.
	<ul style="list-style-type: none"> Piping is clogged by a bag such as the waste disposal bag. 	<ul style="list-style-type: none"> Whenever a bag, such as a waste disposal bag, is used for sterilization. put it in the wire mesh basket and place the basket in the working chamber.
E r 2 (Temperature sensor wire breakage)	<ul style="list-style-type: none"> Temperature in the working chamber falls below the freezing point. 	<ul style="list-style-type: none"> Adjust room temperature at the installation site to 5 - 35°C.
	<ul style="list-style-type: none"> Disconnection of temperature sensor for control. 	<ul style="list-style-type: none"> Contact our authorized distributor in your region.
E r 3 (Excessive temperature alarm)	<ul style="list-style-type: none"> Temperature in the working chamber exceeded the upper limit of the working temperature range by +3°C or more. A temperature + 5°C or more above the set temperature continued for 10 seconds during sterilization. A temperature +10°C or more above the set temperature continued for 15 minutes during warming 	
E r 4 (Excessive cooling alarm)	<ul style="list-style-type: none"> A temperature of 102°C or less continued for 10 seconds during sterilization. 	

Error Number	Problem	Remedy
E r 5 (Excessive pressure alarm)	<ul style="list-style-type: none"> • The pressure of the saturated steam at the set temperature was 0.18MPa or above for HVA-85, 0.24MPa or above for HVA-110 continued in the chamber for 15 seconds. • Piping is clogged by a bag such as the waste disposal bag. 	<ul style="list-style-type: none"> • Contact our authorized distributor in your region. • Whenever a bag, such as a waste disposal bag, is used for sterilization, put it in the wire mesh basket and place the basket in the working chamber.
E r 6 (Lid open alarm)	<ul style="list-style-type: none"> • The open/close lever was moved to the UNLOCK side during operation. 	<ul style="list-style-type: none"> • Contact our authorized distributor in your region.
E r 9 (Sterilization heater alarm)	<ul style="list-style-type: none"> • Temperature in the chamber has not reached a set sterilization temperature after 4 hours has elapsed from operation startup. 	<ul style="list-style-type: none"> • Reduce the quantity of substance to be sterilized and repeat operations from the beginning.
E r L (Open/close level locking failure alarm)	<ul style="list-style-type: none"> • The open/close lever is unlocked during operation. 	<ul style="list-style-type: none"> • Contact our authorized distributor in your region. When contacting the distributor, be sure to have model and serial number information.
E r E (Exhaust bottle anomaly alarm)	<ul style="list-style-type: none"> • The exhaust bottle has moved out of place during operation. 	<ul style="list-style-type: none"> • Push the exhaust bottle into the housing area as far as it will go and repeat operations from the beginning.
E r □ (Power failure alarm)	<ul style="list-style-type: none"> • When power supply is shut off during operation. 	<ul style="list-style-type: none"> • Redo the operation from the beginning.

2. Early Troubleshooting

Symptom	Cause	Remedy
Display remains off after power is turned on.	Check the plug and outlet first. (1) The plug is not properly inserted or is insufficiently tightened. (2) Disconnection in the power cord. (3) Defective display.	(1) Properly insert the plug and retighten any loose parts. (2) (3) Contact the authorized sales distributor from which the unit was purchased.
No air exhausted from the working chamber.	(1) Defective automatic exhaust valve.	(1) Contact our authorized distributor in your region.
Pressure gauge reading remains low.	(1) Defective safety valve. (2) Defective pressure gauge. (3) Disconnection in the heater. (4) Defective automatic exhaust valve. (5) Steam leakage.	(1)-(4) Replace the defective part (Contact the authorized sales distributor from which the unit was purchased). (5) For steam leakage from piping, retighten or seal joints.
Steam leakage from lid gasket	(1) Deterioration of lid gasket (2) Improperly installed lid gasket. (3) Foreign matter under the gasket.	(1) Replace the lid gasket. (2) Press on the gasket to remove any unevenness. (3) Remove the foreign matter.
Water leakage from the bottom of the body.	(1) Deterioration of the heater seal packing due to lack of water or other problem. (2) The drain valve is open.	(1) Contact our authorized distributor in your region. (2) Close the valve.
Open/close lever cannot slide	(1) Temperature in the working chamber has exceeded 80°C or the pressure has exceeded 0.01MPa. (2) The power switch is off.	(1) Wait until the temperature in the working pressure falls below 79°C or the pressure is reduced to 0MPa. (2) Turn on the Power ON/OFF switch.
Lid cannot be opened or closed	(1) The open/close lever has not slid completely to the UNLOCK side.	(1) Slide the lever completely to the UNLOCK side.
Displayed temperature exceeds set temperature and exhaust is repeated frequently during the sterilization cycle.	(1) Defect in the heater circuit.	(1) Contact our authorized distributor in your region.

- This table of early troubleshooting describes the causes and remedies of simple problems. If you are unable to fix or repair the problem, Contact our authorized distributor in your region and provide the following information.
 - (1) Model and serial number of the autoclave.
 - (2) Defective point(s) and symptom(s) (error number if applicable).
 - (3) Number of days of operation (date of purchase).
 - (4) Operating conditions (including substances being sterilized).

Appendix

1. Limited Warranty

- The autoclave is warranted for any trouble that might occur during normal usage for one (1) year from the date of delivery to the user, but not exceeding eighteen (18) months from the date of B/L or AWB from Japan. This warranty does not apply to the troubles caused by any of the items described below:
 - (1) Any force majeure such as a fire, earthquake, or other natural disasters.
 - (2) Disassembly, retrofit, or repair by someone other than us (or our authorized distributors).
 - (3) Incorrect usage.
- In case of trouble, please contact our authorized distributor in your region. In this case, be sure to tell them the name, model and serial number of the product and details of trouble.
- Supply period for spare parts (with charge) for this product shall be seven (7) years after the discontinuance of sales.
- It is recommended to sign a maintenance contract to use the product in the best condition. If you have any questions regarding the maintenance contract, please contact our authorized distributor in your region.

2. Fast wearing parts

Parts name	Applicable Model
Lid gasket	HVA-85 / 110

3. Glossary

■ Autoclave (High Pressure Steam Sterilizer)

Equipment to sterilize, with saturated steam and under a pressure higher than atmospheric pressure, the tools and gauze for medical treatment and surgical operations and media used in laboratories.



HIRAYAMA MANUFACTURING CORPORATION

Overseas Sales Dept.

2-6-5, Toyono-cho, Kasukabe-shi,

Saitama 344-0014, Japan

Tel. (81) 48-735-1242

Fax. (81) 48-733-2384