

INDEX

<b>Digimatic Indicator</b>	
ABSOLUTE Digimatic Indicator ID-S	232
ABSOLUTE Digimatic Indicator ID-U	233
ABSOLUTE Digimatic Indicator ID-C	234
ABSOLUTE Digimatic Indicator ID-H	240
ABSOLUTE Digimatic Indicator ID-F	241
ABSOLUTE Digimatic Indicator ID-N/B	242
EC Counter	243
Multi-Unit, Difference/Sum Unit	243
<b>Dial Indicator</b>	
Dial Indicator	244
Special Dial Indicator	253
Dial Indicator (One Revolution Type)	254
Dial Indicator (Long Stroke Type)	256
Dial Indicator (Large Dial Face and Long Stroke Type)	258
ANSI/AGD Type Metric Dial Indicator	260
Hicator, Signal Hicator	261
Back Plunger Type Dial Indicator	262
Contact Point	264
Back	266
Spindle Lifting Lever and Cable	267
Color Spindle Cap	268
Limit Sticker	268
Dial Indicator Repair Tool Kit	269
Dial Indicator Crystal Setter	269
<b>Dial Test Indicator</b>	
Dial Test Indicator	270
Pocket Type Dial Test Indicator	276
Contact Point, Stem and Clamp Holder	278
<b>Dial Indicator Application</b>	
i-Checker	280
UDT-2 Dial Gage Tester	281
Calibration Tester	281
Thickness Gage	282
Light-Weight Dial Thickness Gage	284
Digimatic Caliper Gage	285
Dial Caliper Gage	286
Bench Gage	288
Upright Gage	289
Dial Snap Gage	290
Female Screw Thread Comparator	291
Roll Caliper	291
Dial Tension Gage	292
V-Block Set	292
<b>Stand</b>	
Magnetic Stand	293
Dial Gage Stand	294
Transfer Stand	295
Granite Comparator Stand	296
Comparator Stand	297
Heavy Duty Comparator Stand	298



**Digimatic Indicator**



**Dial Indicator**

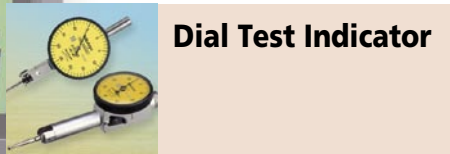

**Dial Test Indicator**

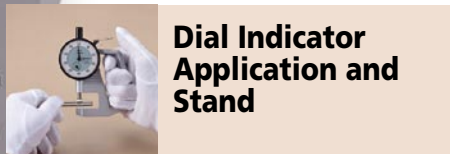

**Dial Indicator Application and Stand**

**New Products**



ID-H

2046S

2109S-10

ID-N / ID-B

Caliper gage

# ABSOLUTE Digimatic Indicator ID-S

**SERIES 543 — with Economical Design**

## FEATURES

- As compact as standard Series 2 dial indicators.
- The ID-S indicates the absolute position of the spindle from the origin point at power-on, allowing to start measurements.
- After the initial zero-setting with the ORIGIN button, the repeated absolute positioning is no longer necessary over the entire battery life.
- Measurement error due to spindle over-speed is eliminated with the ABSOLUTE Encoder.
- SPC data output.



543-690



## SPECIFICATIONS

Metric						
Resolution	Order No. (w/ lug, flat-back)	Range	Accuracy	Measuring force	Remarks	
0.001mm	543-690	543-690B	12.7mm	0.003mm	2.0N or less	—
0.001mm	543-694	543-694B	12.7mm	0.003mm	2.5N or less	Dust-proof
0.01mm	543-681	543-681B	12.7mm	0.02mm	2.0N or less	—

Inch/Metric						
Resolution	Order No. (w/ lug, flat-back)	Range	Accuracy	Measuring force	Remarks	
.00005"/0.001mm	543-691	543-691B	.5"	.00012"	2.0N or less	—
.00005"/0.001mm	543-695	543-695B	.5"	.00012"	2.5N or less	Dust-proof
.00005"/0.001mm	543-692	543-692B	.5"	.00012"	2.0N or less	—
.00005"/0.001mm	543-696	543-696B	.5"	.00012"	2.5N or less	Dust-proof
.0001"/0.001mm	543-693	543-693B	.5"	.00012"	2.0N or less	—
.0005"/0.01mm	543-682	543-682B	.5"	.0008"	2.0N or less	—
.0005"/0.01mm	543-683	543-683B	.5"	.0008"	2.0N or less	—

## DIMENSION

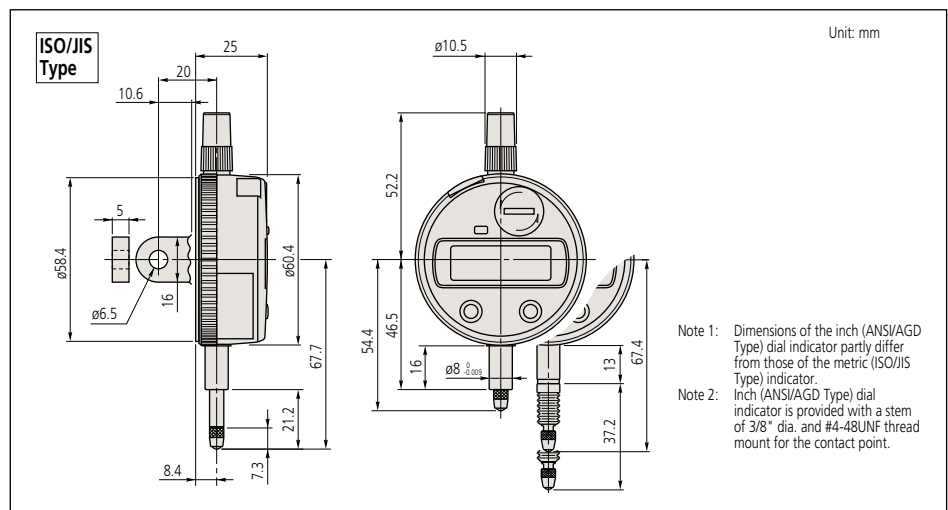

(Refer to the page 9 for details.)

## Technical Data

Accuracy: Refer to the list of specifications (excluding quantizing error)

Resolution: 0.01mm, 0.001mm, .0005"/0.01mm, .0001"/0.001mm or .00005"/0.001mm

Display: LCD

Length standard: ABSOLUTE electrostatic capacitance type linear encoder

Max. response speed: Unlimited

Measuring force: Refer to the list of specifications

Stem dia.: 8mm (ISO/JIS type) or 3/8" (ANSI/AGD type)

Contact point: Carbide ball with M2.5x0.45 (ISO/JIS type) Carbide ball with #4-48UNF (ANSI/AGD type)

Battery: SR44 (1 pc.), **938882**

Battery life: Approx. 20,000 hours under normal use

Dust/Water protection level: IP42 (IP53: **543-694, 543-695, 543-696**)

## Function

Origin-set, Zeraset, Counting direction switching, Power ON/OFF, Data output, inch/mm conversion (inch/mm models)

Alarm: Low voltage, Counting value composition error, Over-flow error

## Optional Accessory

- 905338: SPC cable (1m)
- 905409: SPC cable (2m)
- 903424: Spindle lifting lever (ISO/JIS type)
- 903425: Spindle lifting lever (ANSI/AGD type)
- 540774: Spindle lifting cable
- 125317: Spare rubber boot (for dust-proof type)
- 02ACB610: Back with post
- 02ACB630: Adjustable back
- 02ACB640: Back with offset lug
- 02ACB650: Magnetic back
- 02ACB670: Back with screw mount
- 02ACB680: Back with adjustable bracket
- : Contact points (See page 264.)



**ABSOLUTE**  
Absolute System Patented by MITUTOYO

(Refer to the page 9 for details.)

### Technical Data

Accuracy: Refer to the list of specifications (excluding quantizing error)  
 Resolution: 0.01mm or .0005"/0.01mm,  
 Display: LCD  
 Length standard: ABSOLUTE electrostatic capacitance type linear encoder  
 Max. response speed: Unlimited  
 Measuring force: Refer to the list of specifications  
 Stem dia.: 8mm (ISO/JIS type) or 3/8" (ANSI/AGD type)  
 Contact point: Carbide ball with M2.5x0.45 (ISO/JIS type) Carbide ball with #4-48UNF (ANSI/AGD type)  
 Battery: SR44 (1 pc.), **938882**  
 Battery life: Approx. 20,000 hours under normal use  
 Dust/Water protection level: IP42

### Function

Origin-set, Zeroset, Counting direction switching, Power ON/OFF, Data output, inch/mm conversion (inch/mm models)  
 Alarm: Low voltage, Counting value composition error, Over-flow error

### Optional Accessory

**905338**: SPC cable (1m)  
**905409**: SPC cable (2m)  
**540774**: Spindle lifting cable (stroke: 10mm)  
 —: Contact points (See page 264.)

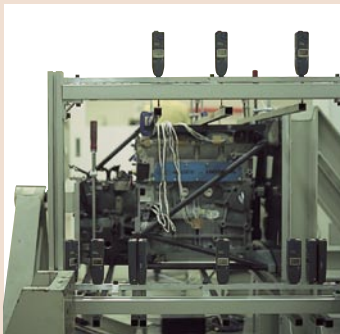

Application example

# ABSOLUTE Digimatic Indicator ID-U

**SERIES 575 — with Slime and Economical Design**

### FEATURES

- Slim type digital indicator with low price.
- Large LCD and simple key operation.
- The ID-U displays the absolute position of the spindle from the origin point at power-on.
- After the initial origin setting, the ID-U no longer needs absolute positioning over the entire battery life; the origin is remembered even after power-off.
- Ideal for installation into measuring devices because of its compact design and long battery life.
- The ABSOLUTE Encoder eliminates spindle over-speed error and prevents electrical noise interference errors.
- SPC data output.



575-121  
IP42

### SPECIFICATIONS

Metric		ISO/JIS type		ANSI/AGD type		
Resolution	Order No. (w/ lug, flat-back)	Range	Accuracy	Measuring force	Remarks	
0.01mm	—	<b>575-121</b>	25.4mm	0.02mm	1.8N or less	—

Inch/Metric		ISO/JIS type		ANSI/AGD type		
Resolution	Order No. (w/ lug, flat-back)	Range	Accuracy	Measuring force	Remarks	
.0005"/0.01mm	—	<b>575-122</b>	1"	.0008"	1.8N or less	—
.0005"/0.01mm	—	<b>575-123</b>	1"	.0008"	1.8N or less	—

### DIMENSION

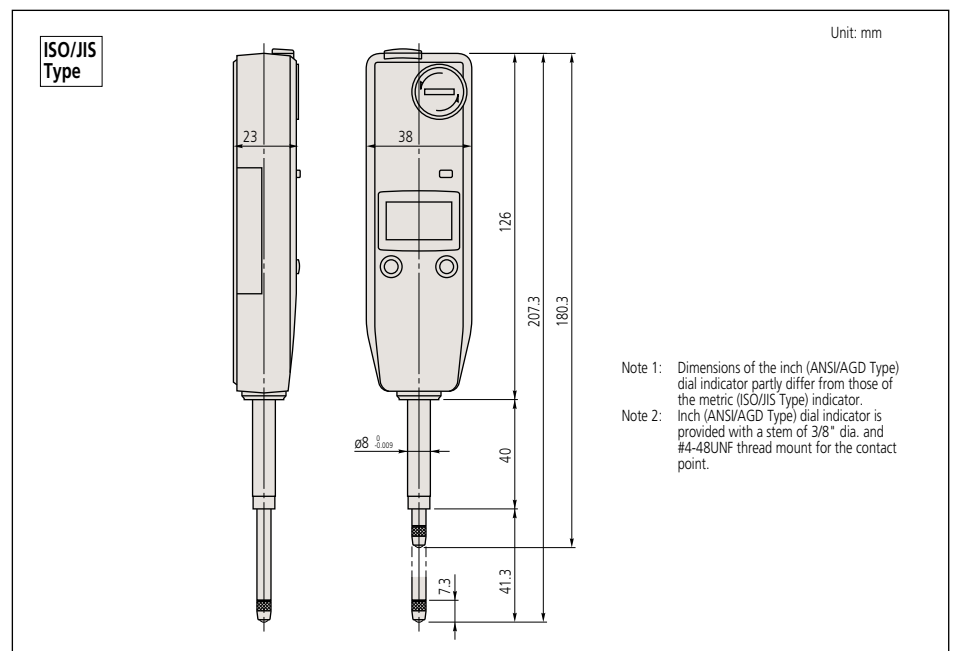

# ABSOLUTE Digimatic Indicator ID-C

## SERIES 543 — Standard Type

### FEATURES

- As compact as standard Series 2 dial indicators.
- Large, easy-to-read LCD.
- ZERO/ABS key: Allows the display to be Zero-Set at any spindle position for comparison measurements. This switch will also allow return to the absolute coordinate and display of the true position from the origin point.
- GO/±NG judgment can be performed by setting upper and lower tolerance limits. The judgment result (GO/±NG) can be displayed in full-size characters.
- Internal calculations using the simple formula of  $[F(x) = Ax]$  are available.
- The positive/negative count resulting from the spindle's up/down movement can be toggled.
- Unlimited response speed eliminates spindle over-speed errors.
- The indicator face can be rotated 330° to an appropriate angle for easy reading.
- With SPC data output.



SPC

**ABSOLUTE**<sup>®</sup>  
Absolute System Patented by MITUTOYO

(Refer to the page 9 for details.)

### Technical Data

Accuracy: Refer to the list of specifications (excluding quantizing error)

Resolution:

0.01mm type	0.01mm
0.001mm type	0.001mm/0.001mm
.0005"/0.01mm type	.0005"/0.01mm
.00005"/0.001mm type	.0005"/.0001"/.00005"/0.01mm/0.001mm

Display: LCD  
Length standard: ABSOLUTE electrostatic capacitance type linear encoder

Max. response speed: Unlimited

Measuring force: Refer to the list of specifications

Stem dia.: 8mm (ISO/JIS type) or 3/8" (ANSI/AGD type)

Contact point: Carbide ball with M2.5x0.45 (ISO/JIS type)  
Carbide ball with #4-48UNF (ANSI/AGD type)

Battery: SR44 (1 pc.), **938882**

Battery life: Approx. 7,000 hours under normal use

Dust/Water protection level: IP42

### Function

Origin-set/Preset, Zeroset, GO/±NG judgment, Counting direction switching, Power ON/OFF, Simplified calculation, Function lock, Data hold, Data output, inch/mm conversion (inch/mm models)

Alarm: Low voltage, Counting value composition error, Over-flow error, Tolerance limit setting error

### Optional Accessory

**905338**: SPC cable (1m)

**905409**: SPC cable (2m)

**21EZA198**: Spindle lifting lever (12.7mm/.5" ISO/JIS type)

**21EZA199**: Spindle lifting lever (12.7mm/.5" ANSI/AGD type)

**21EZA105**: Spindle lifting knob (12.7mm/.5" ISO/JIS type)\*

**21EZA150**: Spindle lifting knob (12.7mm/.5" ANSI/AGD type)\*

**21EZA197**: Spindle lifting knob (25.4mm/1", 50.8mm/2" models)

**540774**: Spindle lifting cable

**02ACA571**: Auxiliary spindle spring (25.4mm/1" models)\*\*

**02ACA773**: Auxiliary spindle spring (50.8mm/2" models)\*\*

Backs (See page 266.)

—: Lug-on-center back (25.4mm/1" and

50.8mm/2", ISO/JIS type)

—: Lug-on-center back (25.4mm/1" and

50.8mm/2", ANSI/AGD type)

—: Contact points (See page 264.)

\*Not available for low measuring force models.

\*\*Required when orienting the indicator upside down.

## SPECIFICATIONS

Metric		ISO/JIS type	ANSI/AGD type			
Resolution*	Order No. (w/ lug, flat-back)	Range	Accuracy	Measuring force	Remarks	
0.001mm	<b>543-390</b> <b>543-390B</b>	12.7mm	0.003mm	1.5N or less	—	
0.001mm	<b>543-394</b> <b>543-394B</b>	12.7mm	0.003mm	0.4N - 0.7N	Low measuring force	
0.001mm	— <b>543-470B</b>	25.4mm	0.003mm	1.8N or less	—	
0.001mm	— <b>543-490B</b>	50.8mm	0.005mm	2.3N or less	—	
0.01mm	<b>543-400</b> <b>543-400B</b>	12.7mm	0.02mm	0.9N or less	—	
0.01mm	<b>543-404</b> <b>543-404B</b>	12.7mm	0.02mm	0.2N - 0.5N	Low measuring force	
0.01mm	— <b>543-474B</b>	25.4mm	0.02mm	1.8N or less	—	
0.01mm	— <b>543-494B</b>	50.8mm	0.04mm	2.3N or less	—	

## Inch/Metric

Resolution*	Order No. (w/ lug, flat-back)	Range	Accuracy	Measuring force	Remarks	
.00005"/0.001mm	<b>543-391</b> <b>543-391B</b>	.5"	.0001"	1.5N or less	—	
.00005"/0.001mm	<b>543-392</b> <b>543-392B</b>	.5"	.0001"	1.5N or less	—	
.00005"/0.001mm	<b>543-395</b> <b>543-395B</b>	.5"	.0001"	0.4N - 0.7N	Low measuring force	
.00005"/0.001mm	<b>543-396</b> <b>543-396B</b>	.5"	.0001"	0.4N - 0.7N	Low measuring force	
.00005"/0.001mm	— <b>543-471B</b>	1"	.0001"	1.8N or less	—	
.00005"/0.001mm	— <b>543-472B</b>	1"	.0001"	1.8N or less	—	
.00005"/0.001mm	— <b>543-491B</b>	2"	.0002"	2.3N or less	—	
.00005"/0.001mm	— <b>543-492B</b>	2"	.0002"	2.3N or less	—	
.0005"/0.01mm	<b>543-401</b> <b>543-401B</b>	.5"	.001"	0.9N or less	—	
.0005"/0.01mm	<b>543-402</b> <b>543-402B</b>	.5"	.001"	0.9N or less	—	
.0005"/0.01mm	<b>543-405</b> <b>543-405B</b>	.5"	.001"	0.2N - 0.5N	Low measuring force	
.0005"/0.01mm	<b>543-406</b> <b>543-406B</b>	.5"	.001"	0.2N - 0.5N	Low measuring force	
.0005"/0.01mm	— <b>543-475B</b>	1"	.001"	1.8N or less	—	
.0005"/0.01mm	— <b>543-476B</b>	1"	.001"	1.8N or less	—	
.0005"/0.01mm	— <b>543-495B</b>	2"	.0015"	2.3N or less	—	
.0005"/0.01mm	— <b>543-496B</b>	2"	.0015"	2.3N or less	—	

## DIMENSION

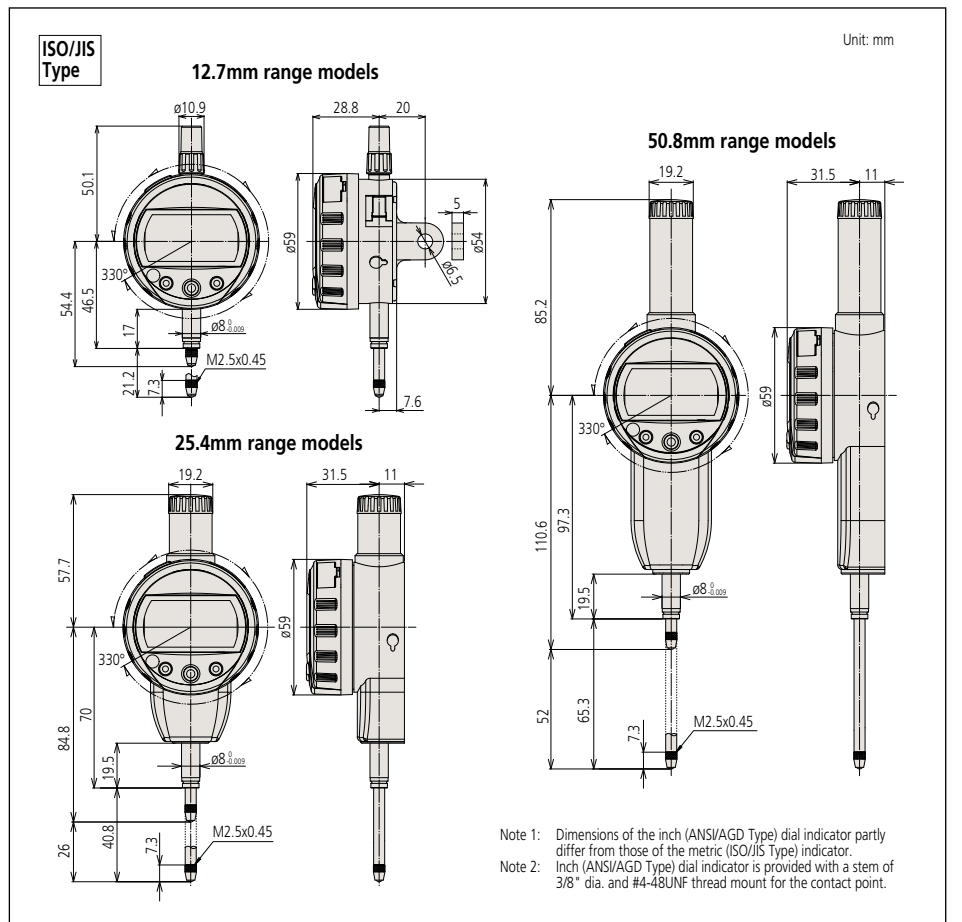

# ABSOLUTE Digimatic Indicator ID-C

## SERIES 543 — Calculation Type

### FEATURES

A conventional Digimatic indicator simply displays a spindle displacement, but the Calculation-Type Digimatic indicator incorporates an internal calculation function in place of spindle displacement. With fixtures, measurements such as feeler, inside diameter and radius of curvature measurement can easily be obtained without the hassle of conversion tables or equivalents.

- The Absolute Digimatic indicator performs internal calculations using the formula  $Ax+B+Cx^{-1}$  (assuming spindle displacement as  $x$ ) while the specified coefficients  $A$ ,  $B$  and  $C$  can be set with respect to the purpose of measurement or dimensions of the fixtures. This unique features allows you to read your measurements directly, without fumbling for conversions.



543-285B

### SPECIFICATIONS

Metric			
Resolution	Order No.*	Range	Accuracy
0.0002 - 1mm (switchable)	543-285B	12.7mm	0.003mm
	543-480B	25.4mm	0.003mm
	543-485B	50.8mm	0.006mm

\*Flat back

ISO/JIS type

ANSI/AGD type

Inch/Metric			
Resolution	Order No.*	Range	Accuracy
.00001" - .05"/ 0.0002 - 1mm (switchable)	543-286B	.5"	.00012"
	543-287B	.5"	.00012"
	543-481B	1"	.00012"
	543-482B	1"	.00012"
	543-486B	2"	.00025"
	543-487B	2"	.00025"

\*Flat back

### DIMENSION

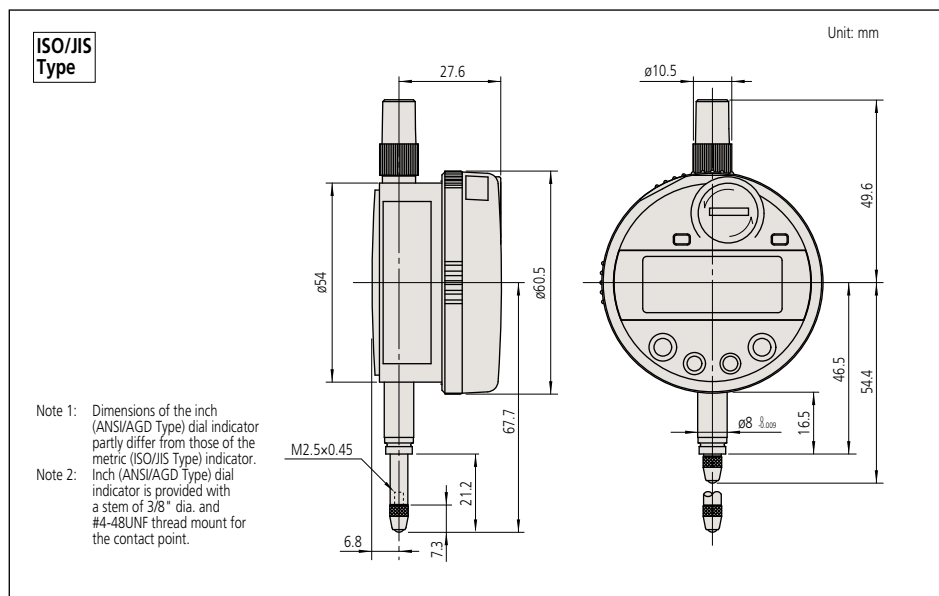

(Refer to the page 9 for details.)

### Technical Data

- Accuracy: Refer to the list of specifications (excluding quantizing error)
- Resolution: 0.0002mm - 1mm or .00001" - .05"/0.0002mm - 1mm
- Display: LCD
- Length standard: ABSOLUTE electrostatic capacitance type linear encoder
- Max. response speed: Unlimited
- Measuring force: 1.5N or less
- Stem dia.: 8mm (ISO/JIS type) or 3/8" (ANSI/AGD type)
- Contact point: Carbide ball with M2.5x0.45 (ISO/JIS type) Carbide ball with #4-48UNF (ANSI/AGD type)
- Battery: SR44 (1 pc.), 938882
- Battery life: Approx. 12 months under normal use

### Function

- Origin-set/Presets, Zerose, GO/±NG judgment, Counting direction switching, Power ON/OFF, Data output, inch/mm conversion (inch/mm models)
- Alarm: Low voltage, Counting value composition error, Over-flow error, Tolerance limit setting error

### Optional Accessory

- 905338: SPC cable (1m)
- 905409: SPC cable (2m)
- 902011: Spindle lifting lever (ISO/JIS type)
- 540774: Spindle lifting cable
- Backs (See page 266.)
- Contact points (See page 264.)

### APPLICATIONS



- Various fixtures suited for individual workpieces can be prepared.
- Measuring accuracy is subject to fixture accuracy



# ABSOLUTE Digimatic Indicator ID-C

## SERIES 543 — with Max./Min. Value Holding Function

With max./min. value holding function model of the ID-C Series Digimatic Indicators.

### FEATURES

- The maximum, minimum, or runout value can be displayed during measurement.
- GO/±NG judgment is performed by setting the upper and lower tolerances for max., min. and runout values.
- High speed sampling ratio of 50 times/s.



543-262

### SPECIFICATIONS

Metric			
Resolution	Order No.*	Range	Accuracy
0.001mm	<b>543-260</b>	12.7mm	0.003mm

\*Back with lug

ISO/JIS type

ANSI/AGD type

Inch/Metric			
Resolution	Order No.*	Range	Accuracy
.00005"/0.001mm	<b>543-261</b>	.5"	.00012"
.00005"/0.001mm	<b>543-262</b>	.5"	.00012"
.0001"/0.001mm	<b>543-263</b>	.5"	.00012"

\*Back with lug

### DIMENSION

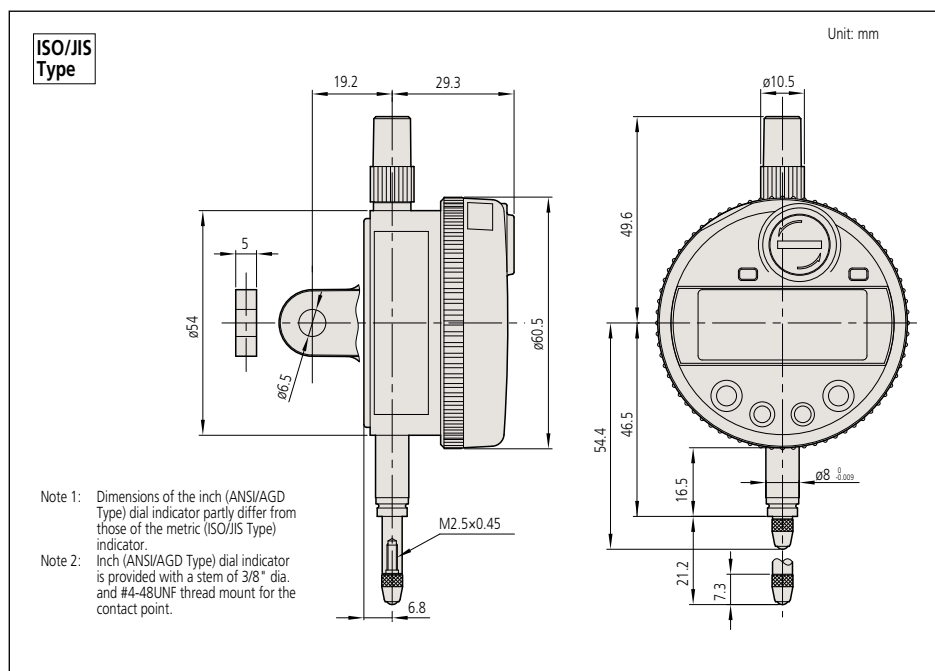

(Refer to the page 9 for details.)

### Technical Data

Accuracy: Refer to the list of specifications (excluding quantizing error)  
 Resolution: 0.001mm, .00005"/0.001mm or .0001"/0.001mm  
 Display: LCD  
 Length standard: ABSOLUTE electrostatic capacitance type linear encoder  
 Max. response speed: Unlimited  
 Measuring force: 1.5N or less  
 Stem dia.: 8mm (ISO/JIS type) or 3/8" (ANSI/AGD type)  
 Contact point: Carbide ball with M2.5x0.45 (ISO/JIS type) Carbide ball with #4-48UNF (ANSI/AGD type)  
 Battery: SR44 (2 pcs.), **938882**  
 Battery life: Approx. 800 - 1300 hours under normal use  
 Dust/Water protection level: IP42

### Function

Origin-set/Preset, Zeroset, GO/±NG judgment, Max/Min/Runout value holding, Counting direction switching, Power ON/OFF, Data output, inch/mm conversion (inch/mm models)  
 Alarm: Low voltage, Counting value composition error, Over-flow error, Tolerance limit setting error

### Optional Accessory

**905338:** SPC cable (1m)  
**905409:** SPC cable (2m)  
**902011:** Spindle lifting lever (ISO/JIS type)  
**902794:** Spindle lifting lever (ANSI/AGD type)  
**540774:** Spindle lifting cable  
 \_\_\_\_\_: Backs (See page 266.)  
 \_\_\_\_\_: Contact points (See page 264.)



Absolute System Patented by MITUTOYO

(Refer to the page 9 for details.)

### Technical Data

Accuracy: Refer to the list of specifications (excluding quantizing error)  
 Resolution: 0.001mm or .00005"/0.001mm  
 Display: LCD  
 Length standard: ABSOLUTE electrostatic capacitance type linear encoder  
 Max. response speed: Unlimited  
 Measuring force: 1.5N or less  
 Stem dia.: 8mm (ISO/JIS type) or 3/8" (ANSI/AGD type)  
 Contact point: Carbide ball with M2.5x0.45 (ISO/JIS type) Carbide ball with #4-48UNF (ANSI/AGD type)  
 Battery: SR44 (2 pcs.), **938882**  
 Battery life: Approx. 2000 hours under normal use  
 Dust/Water protection level: IP42

### Function

Origin-set/Preset, Zeroset, GO/±NG judgment, Counting direction switching, Power ON/OFF, Data output, inch/mm conversion (inch/mm models)  
 Alarm: Low voltage, Counting value composition error, Over-flow error, Tolerance limit setting error

### Optional Accessory

**905338:** SPC cable (1m)  
**905409:** SPC cable (2m)  
**526-170:** Bore gage probe (0.95 - 1.55mm)  
**526-160:** Bore gage probe (1.5 - 4.0mm)  
**526-150:** Bore gage probe (3.7 - 7.3mm)  
**526-101:** Bore gage probe (7.0 - 10.0mm)  
**526-102:** Bore gage probe (10 - 18mm)  
**526-126:** Bore gage probe (18 - 35mm)  
**526-127:** Bore gage probe (35 - 60mm)  
**526-132:** Bore gage probe (50 - 150mm)



Installed on bore gage probe (**511-127**)

# ABSOLUTE Digimatic Indicator ID-C

## SERIES 543 — Specially Designed for Bore Gage Application

This ID-C Series Digimatic Indicators are exclusively designed for ID measurement.

### FEATURES

- The minimum value holding function provides the easy of detection of hole diameter.
- An analog bar indicator is integrated to enhance the intuition in reading.
- GO/±NG judgment is performed by setting the upper and lower tolerances.
- Up to three sets of master value and upper/lower tolerance value can be memorized.



543-264B

### SPECIFICATIONS

Metric			
Resolution	Order No.*	Range	Accuracy
0.001mm	<b>543-264B</b>	12.7mm	0.003mm

\*Back with lug

Inch/Metric			
Resolution	Order No.*	Range	Accuracy
.00005"/0.001mm	<b>543-266B</b>	.5"	.00012"

\*Back with lug

ISO/JIS type

ANSI/AGD type

### DIMENSION

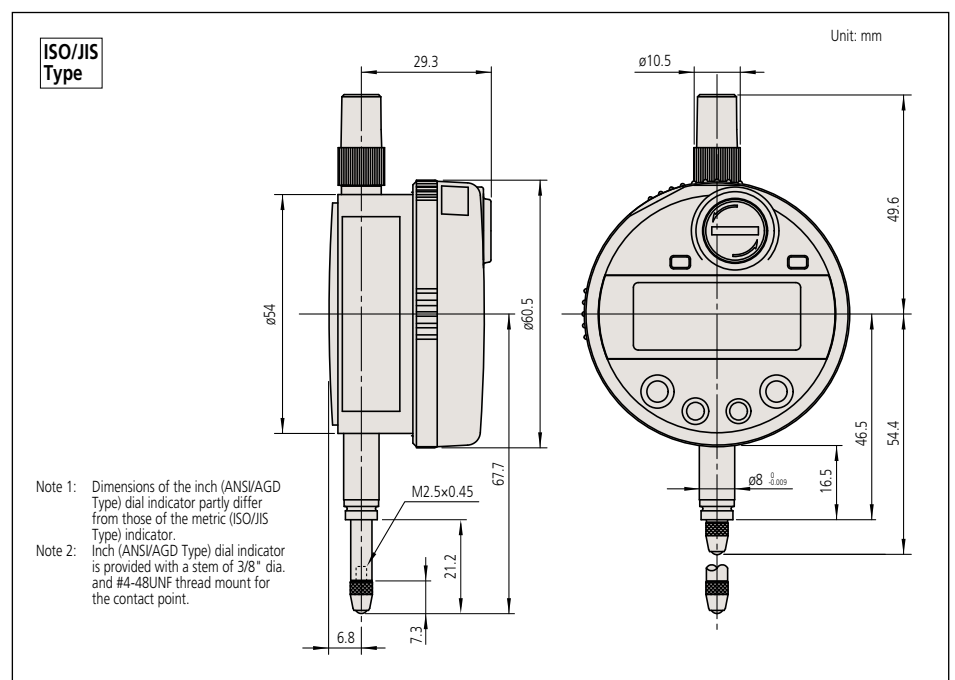

# ABSOLUTE Digimatic Indicator ID-H

## SERIES 543 — High Accuracy and High Functional Type

### FEATURES

- This new-generation digital indicator offers the excellent accuracy and functionality expected from this class of indicator. Take advantage of its high accuracy backed up by 0.5μm / .00002" resolution, remote control functionality via a handheld controller (or an RS-232C interface) and easy runout measurements with the well-established analog bar display.
- The maximum, minimum, or runout value can be displayed during measurement.
- GO/±NG judgment is performed by setting the upper and lower tolerances. If a judgment result is out of tolerance, the display backlighting changes from green to red, so tolerance judgment can be made at a glance.
- With SPC data output.
- With RS-232C input/output



Remote controller (optional)



543-561

543-563

### SPECIFICATIONS

Metric			
Resolution	Order No.*	Range	Accuracy
0.0005mm, 0.001mm	<b>543-561</b>	30.4mm	0.0015mm
	<b>543-563</b>	60.9mm	0.0025mm

\* To denote your AC line voltage add the following suffixes to the order No.  
**A** for 120V **K** for 100V **D** for 220V **E** for 240/220V **DC** for China  
**No suffix** is required for 100V

Inch/Metric			
Resolution	Order No.*	Range	Accuracy
.00005", .0001"	<b>543-562</b>	1.2"	0.0015mm
0.0005mm, 0.001mm	<b>543-564</b>	2.4"	0.0025mm

\* To denote your AC line voltage add the following suffixes to the order No.  
**A** for 120V **K** for 100V **D** for 220V **E** for 240/220V **DC** for China  
**No suffix** is required for 100V

### Tolerance judgment



### Analog bar display



### Max/Min value measurement



### Runout measurement



### Resolution switching



### DIMENSION

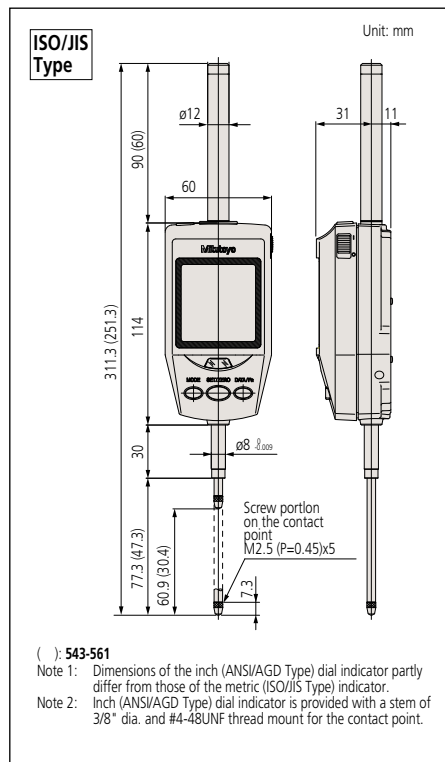

(Refer to the page 9 for details.)

### Technical Data

- Accuracy: Refer to the list of specifications (excluding quantizing error)
- Resolution: 0.0005mm/0.001mm or .00002"/.00005"/.0001"/0.0005mm/0.001mm
- Display: LCD
- Length standard: Linear encoder
- Max. response speed: 1000mm/s
- Measuring force: 2.0N/2.5N\* or less (\*60mm range models)
- Stem dia.: 8mm (ISO/JIS type) or 3/8" (ANSI/AGD type)
- Contact point: Carbide ball with M2.5x0.45 (ISO/JIS type)  
 Carbide ball with #4-48UNF (ANSI/AGD type)
- Power supply: 6V DC (via AC adaptor)

### Function

- Origin-set/Preset, Zeroset, GO/±NG judgment, Max/Min value hold, Runout measurement, Resolution switching, Counting direction switching, Power ON/OFF, Data output, inch/mm conversion (inch/mm models)
- Alarm: Low voltage, Counting value composition error, Over-flow error, Tolerance limit setting error

### Optional Accessory

- 936937:** SPC cable (1m)
- 965014:** SPC cable (2m)
- 21EAA131:** RS-232C cable (2m)
- 21EZA099:** Remote controller
- 540774:** Spindle lifting cable (stroke: 30mm)
- 21EZA101:** Spindle lifting knob
- 264-504:** Digimatic Min-processor DP-1VR
- 543-004:** Digimatic presetter
- 215-154:** Granite comparator stand
- 215-504:** Comparator stand
- 215-821:** Comparator stand
- Backs (See page 266.)
- Contact points (See page 264.)

\*Required when orienting the indicator upside down.

### Application

#### Difference/Runout measurement

**Example: Indicator travel from points A to D**  
 Difference (or Total Runout) is displayed as A. Dimensions B (maximum value) and C (minimum value) can be recalled from memory with a simple key sequence.

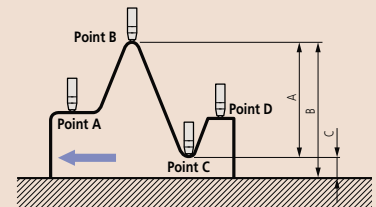



(Refer to the page 9 for details.)

### Technical Data

Accuracy: Refer to the list of specifications (excluding quantizing error)  
 Resolution: 0.01mm/0.001mm or .00005"/.0001"/.0005"/.001"/0.001mm/0.01mm  
 Display: LCD  
 Length standard: ABSOLUTE electrostatic capacitance type linear encoder  
 Max. response speed: Unlimited  
 Measuring force: 1.8N/2.3N\* or less (\*50mm range models)  
 Stem dia.: 8mm (ISO/JIS type) or 3/8" (ANSI/AGD type)  
 Contact point: Carbide ball with M2.5x0.45 (ISO/JIS type) Carbide ball with #4-48UNF (ANSI/AGD type)  
 Power supply: 9V DC (via AC adaptor)

### Function

Origin-set/Preset, Zeroset, GO/±NG judgment, Max/Min value hold, Runout measurement, Resolution switching, Counting direction switching, Power ON/OFF, Data output, inch/mm conversion (inch/mm models)  
 Alarm: Low voltage, Counting value composition error, Over-flow error, Tolerance limit setting error

### Optional Accessory

- 936937: SPC cable (1m)
- 965014: SPC cable (2m)
- 21EAA131: RS-232C cable (2m)
- 540774: Spindle lifting cable (stroke: 10mm)
- 02ACA571: Auxiliary spindle spring for 25mm/1" models\*
- 02ACA773: Auxiliary spindle spring for 50mm/2" models\*
- 264-504: Digimatic Min-processor DP-1VR
- 543-004: Digimatic presetter
- 215-154: Granite comparator stand
- 215-504: Comparator stand
- 215-821: Comparator stand
- : Backs (See page 266.)
- : Contact points (See page 264.)

\*Required when orienting the indicator upside down.

### Application

#### Difference/Runout measurement

Example: Indicator travel from points A to D  
 Difference (or Total Runout) is displayed as A. Dimensions B (maximum value) and C (minimum value) can be recalled from memory with a simple key sequence.

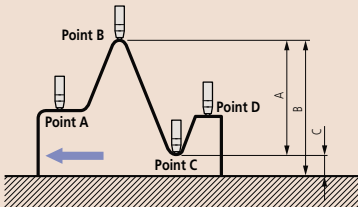

# ABSOLUTE Digimatic Indicator ID-F

## SERIES 543 — with Back-lit LCD Screen

### FEATURES

- With the ABSOLUTE Linear Encoder technology, once the measurement reference point has been preset it will not be lost when the power is turned on.
- GO/±NG judgment is performed by setting the upper and lower tolerances. If a judgment result is out of tolerance, the display backlighting changes from green to red, so tolerance judgment can be made at a glance.



- The maximum, minimum, or runout value can be displayed during measurement.

- An analog bar indicator has been integrated to handle upper/lower limit approaching and zero approaching. It enhances the ease of operation in the same manner as a dial indicator. The display range of the analog bar can be changed.
- With SPC data output.



### SPECIFICATIONS

Metric			
Resolution	Order No.*	Range	Accuracy
0.001mm, 0.01mm	543-551	25mm	0.003mm
	543-557	50mm	0.003mm
	543-553	50mm	0.006mm

\* To denote your AC line voltage add the following suffixes to the order No.  
 A for 120V K for 100V D for 220V E for 240/220V DC for China  
 No suffix is required for 100V

Inch/Metric			
Resolution	Order No.*	Range	Accuracy
.00002", .00005", .0001", .0005", .001", 0.001mm, 0.01mm	543-552	1"	.00012"
	543-558	2"	.00012"
	543-554	2"	.00024"

\* To denote your AC line voltage add the following suffixes to the order No.  
 A for 120V K for 100V D for 220V E for 240/220V DC for China  
 No suffix is required for 100V

### DIMENSION

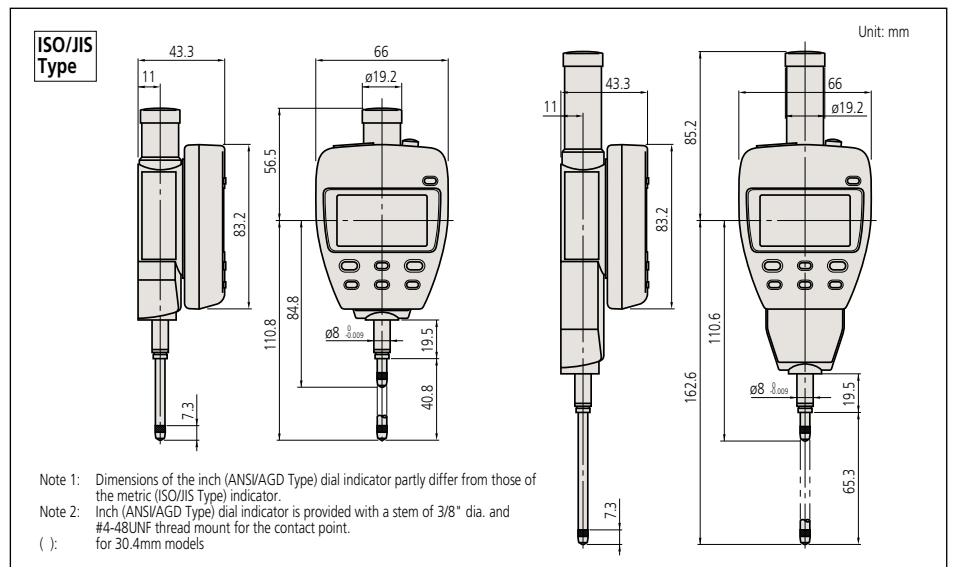

# ABSOLUTE Digimatic Indicator ID-N / B

**SERIES 543 — with Dust/Water Protection Conforming to IP66**

## FEATURES

- Proven ABSOLUTE sensor.
- Rated to IP66 water- and dust-proofing standard and oil resistance improved.
- Slim body design is advantageous for multi-point measurements.
- Improvement in workability with the LCD readout-rotation function.
- Back plunger design (ID-B).
- Built-in tolerance judgment function.
- Switchable resolution.
- Waterproof data output connector.
- Built-in hold/preset function



Slim type ID-N  
543-575

Back plunger type ID-B  
543-585

## SPECIFICATIONS

Metric				
Resolution	Order No.	Range	Accuracy	Remarks
0.01mm	543-570	12.7mm	0.02mm	Slim type ID-N
0.01mm	543-580	5.0mm	0.02mm	Back plunger type ID-B
0.01mm / 0.001mm	543-575	12.7mm	0.01mm / 0.003mm	Slim type ID-N
0.01mm / 0.001mm	543-585	5.0mm	0.01mm / 0.003mm	Back plunger type ID-B

Inch/Metric				
Resolution	Order No.	Range	Accuracy	Remarks
.0005", 0.01mm	543-571	.5"	.0008"	Slim type ID-N
	543-581	.2"	.0008"	Back plunger type ID-B
0.01mm / 0.001mm .0005" / .00005"	543-576	.5"	.0004" / .00012"	Slim type ID-N
	543-586	.2"	.0004" / .00012"	Back plunger type ID-B

## DIMENSION

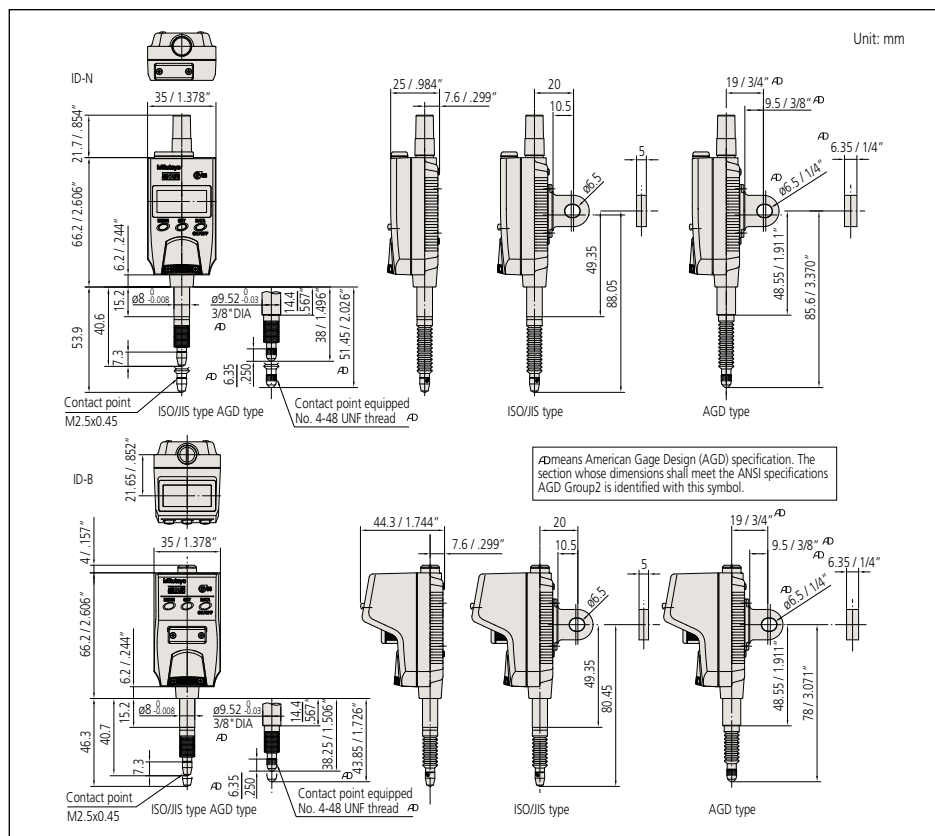

(Refer to the page 9 for details.)



(Refer to the page 9 for details.)



## Technical Data

Accuracy: Refer to the list of specifications (excluding quantizing error)  
 Resolution: 0.01mm, 0.01mm/0.001mm, .0005"/0.01mm or .0005"/.00005"/0.01mm/0.001mm  
 Display: LCD  
 Length standard: ABSOLUTE electrostatic capacitance type linear encoder  
 Max. response speed: Unlimited  
 Measuring force: 2.5N (2.0N: Back plunger type)  
 Stem dia.: 8mm (3/8": inch/metric models)  
 Contact point: Carbide ball with M2.5x0.45 (#4-48UNF: inch/metric models)  
 Battery: SR44 (1 pc.), **938882**  
 Battery life: Approx. 7000 hours under normal use  
 Dust/Water protection level: IP66

## Function

Zero-setting, Presetting, Direction switching, Tolerance judgment, Display hold, Data output, inch/mm conversion (inch/mm models)  
 Alarm: Low voltage, Counting value composition error, Over-flow error, Tolerance limit setting error

## Optional Accessory

- 21EZA105: Lifting knob (for ISO/JIS model)
- 21EZA150: Lifting knob (for AGD model)
- 21EZA145: Lug (for JIS/ISO model)
- 21EZA146: Lug (for AGD model)
- 02ACA376: Rubber boot (for ID-N, NBR)
- 238774: Rubber boot (for ID-N, silicon)
- 125317: Rubber boot (for ID-B, NBR)
- 21EAA212: Rubber boot (for ID-B, silicon)
- 21EAA194: Connecting cable (1m)
- 21EAA190: Connecting cable (2m)
- 21EAA210: Bifurcated connecting cable with zero-setting terminal (1m)
- 21EAA211: Bifurcated connecting cable with zero-setting terminal (2m)

—: Contact points (See page 264.)



# EC Counter

## SERIES 543 — Low-cost, Assembly, Type Display Unit

### FEATURES

- Employed the DIN size (96 X 48mm) and mount-on-panel configuration, which greatly facilitates the incorporation into a system.
- Possible to produce either tolerance judgment output or Digimatic output.



EC Counter

**Order No.: 542-007**

Function: Preset, GO/±NG judgment

### DIMENSION

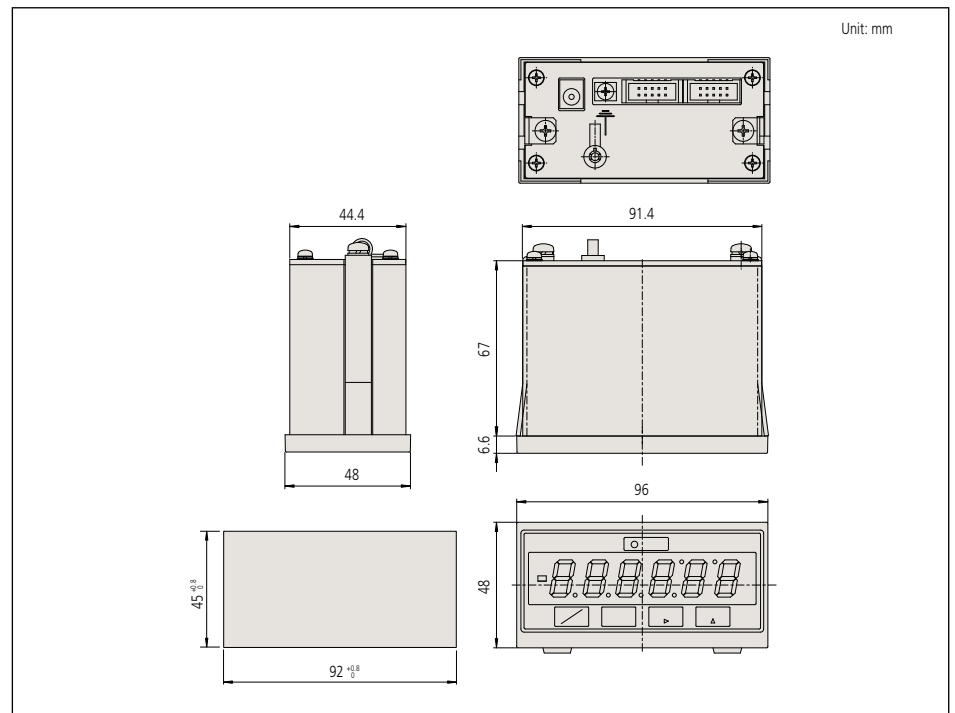

# Dial Indicator

## FEATURES: S Series

- Revolutionary stem-bush design for trouble free stem clamping (longer clamping range).
- No through screw-hole on the frame for high dust-resistance.

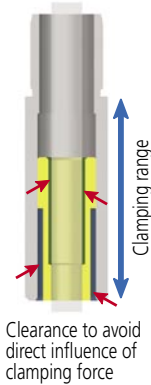

- Involute curved lifting lever for smooth movement of spindle and dovetail joint for tool-less connection.
- Grater rigidity in the bearing plate for reducing the retracing error (20%) and 4-screw mounting for increasing impact resistance.

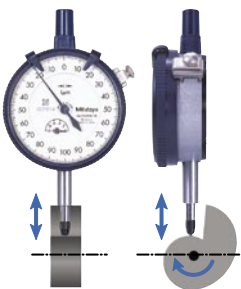
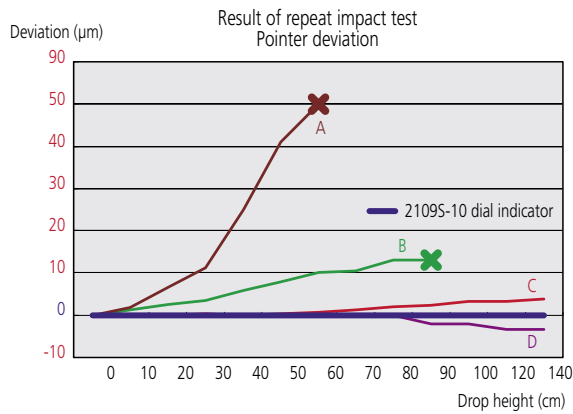
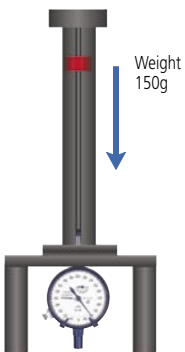
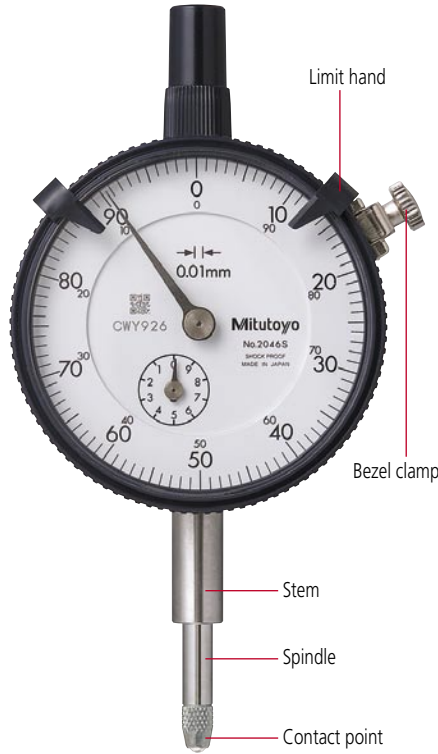
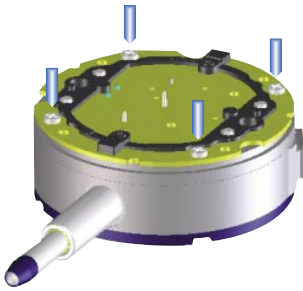

Endurance testing with cam  
Rotation speed: 120rpm

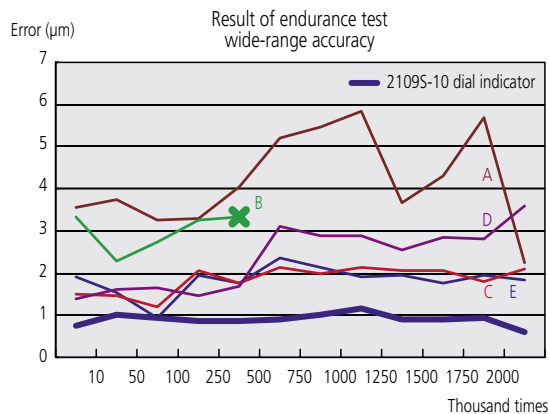

## Description of Icon

Icon	Description
	Reverse reading type suitable for depth and step measurement.
	One revolution type for easy and error-free reading
	Double scale spacing type, easy-on-the-eyes
	Shockproof type
	Waterproof type
	With damper at lowest rest point
	Jeweled bearing type
	Peak retaining type
	Long stem type
	Dustproof type
	With coaxial revolution counter
	Back plunger type
	Adjustable hand type
	Double-face type

# Dial Indicator

## SERIES 1 — Compact One Revolution Type for Error-free Reading



(Refer to the page 9 for details.)



One revolution type



1929S  
1929S-60  
1929S-62



1900S-10  
1900S-70  
1900S-72



1929S

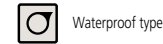
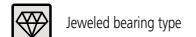
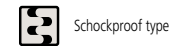
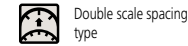

Waterproof type

### SPECIFICATIONS

Graduation	Order No.		Range (range/rev)	Accuracy	Dial reading	Measuring force	ISO/JIS type						
	w/ lug	Flat-back					Double scale spacing type	Jeweled bearing type	Shockproof type	Dustproof type	Waterproof type	—	
0.01mm	1929S	1929SB	1mm / 1.4mm	±11μm	50-0-50	1.4N or less	—	—	—	—	—	—	—
0.01mm	1929S-60	1929SB-60	1mm / 1.4mm	±11μm	50-0-50	1.4N or less	—	—	—	—	—	—	—
0.01mm	1929S-62	1929SB-62	1mm / 1.4mm	±11μm	50-0-50	1.4N or less	—	—	—	—	—	—	—
0.001mm	1900S-10	1900SB-10	0.1mm / 0.14mm	±6μm	50-0-50	1.5N or less	—	—	—	—	—	—	—
0.001mm	1900S-70	1900SB-70	0.1mm / 0.14mm	±6μm	50-0-50	1.5N or less	—	—	—	—	—	—	—
0.001mm	1900S-72	1900SB-72	0.1mm / 0.14mm	±6μm	50-0-50	1.5N or less	—	—	—	—	—	—	—

Graduation	Order No.		Range (range/rev)	Accuracy	Dial reading	Measuring force	ANSI/AGD type						
	w/ lug	Flat-back					Double scale spacing type	Jeweled bearing type	Shockproof type	Dustproof type	Waterproof type	—	
.0005"	1909S-62	1909SB-62	.04" / .055"	±.0005"	20-0-20	1.4N or less	—	—	—	—	—	—	—
.0001"	1910S-72	1910SB-72	.006" / .0079"	±.0001"	3-0-3	1.4N or less	—	—	—	—	—	—	—

### Optional Accessory

- : Backs (See page 266.)
- : Contact points (See page 264.)

### DIMENSION

ISO/JIS Type

Unit: mm

Note 1: Dimensions of the inch (ANSI/AGD Type) dial indicator partly differ from those of the metric (ISO/JIS Type) indicator.  
 Note 2: Inch (ANSI/AGD Type) dial indicator is provided with a stem of 3/8" dia. and #4-48UNF thread mount for the contact point.

Order No.	A	B	C
1929S	47.5	13.8	13.7
1929S-60	55.5	12.2	23.3
1929S-62	47.5	13.8	13.7
1900S-10	53.5	16.8	16.7
1900S-70	54.5	12.2	22.3
1900S-72	53.5	16.8	16.7

# Dial Indicator

## SERIES 1 — Compact Type

Mitutoyo's Series 1 dial indicators offer the accuracy and durability for shop applications demanding highly accurate measurements where space is limited. The spindle is made of hardened stainless steel for durability, while the rack gear is machine ground for a tighter fit and increased accuracy.



1911



1911



1003

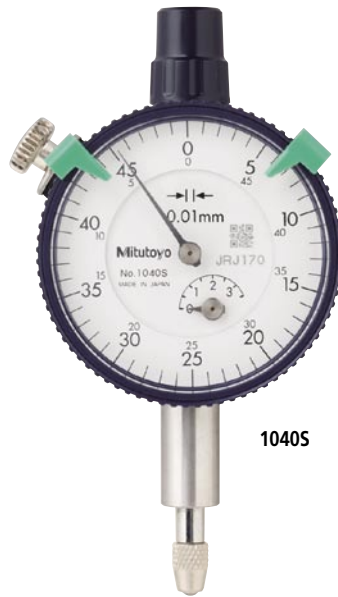

1040S



1913-10



1003

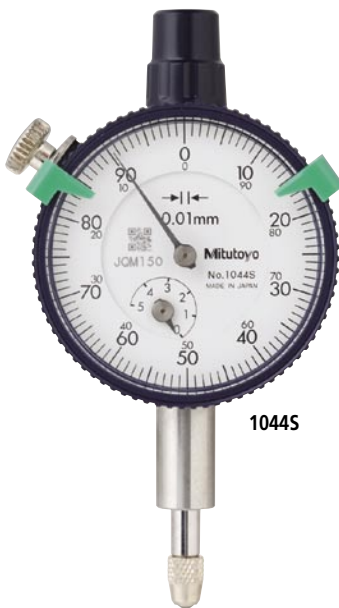

1044S



1109S-10



(Refer to the page 9 for details.)

### Optional Accessory

- : Backs (See page 266.)
- : Contact points (See page 264.)



Double scale spacing type



Jeweled bearing type



Waterproof type



Shockproof type



Dustproof type

## SPECIFICATIONS

## Metric

ISO/JIS type

Graduation	Order No.		Range (range/rev)	Accuracy	Dial reading	Measuring force						—
	w/ lug	Flat-back										
0.01mm	<b>1911</b>	<b>1911B</b>	2.5mm (1mm)	±12μm	0-50-0	1.8N or less	—	—	—	—	—	—
0.002mm	<b>1913-10</b>	<b>1913B-10</b>	0.5mm (0.2mm)	±8μm	0-100-0	1.5N or less	—	✓	—	—	—	—
0.01mm	<b>1003</b>	<b>1003B</b>	4mm (1mm)	±13μm	0-50-0	1.4N or less	—	—	—	—	—	—
0.01mm	<b>1044S</b>	<b>1044SB</b>	5mm (1mm)	±13μm	0-100	1.4N or less	—	—	—	—	—	—
0.01mm	<b>1045S</b>	<b>1045SB</b>	5mm (1mm)	±13μm	0-50-0	1.4N or less	—	—	—	—	—	—
0.01mm	<b>1044S-10</b>	<b>1044SB-10</b>	5mm (1mm)	±13μm	0-100	0.4N or less*	—	✓	—	—	—	—
0.01mm	<b>1044S-60</b>	<b>1044SB-60</b>	5mm (1mm)	±13μm	0-100	2.0N or less	—	—	✓	—	—	—
0.01mm	<b>1040S</b>	<b>1040SB</b>	3.5mm (0.5mm)	±13μm	0-50	1.4N or less	✓	—	—	—	—	—
0.01mm	<b>1041S</b>	<b>1041SB</b>	3.5mm (0.5mm)	±13μm	0-25-0	1.4N or less	✓	—	—	—	—	—
0.005mm	<b>1124S</b>	<b>1124SB</b>	3.5mm (0.5mm)	±13μm	0-50	1.4N or less	—	✓	—	—	—	—
0.001mm	<b>1109S-10</b>	<b>1109SB-10</b>	1mm (0.2mm)	±7μm	0-100-0	1.5N or less	—	✓	—	—	—	—
0.002mm	<b>1013S-10</b>	<b>1013SB-10</b>	1mm (0.2mm)	±10μm	0-100-0	1.5N or less	—	✓	—	—	—	—

\*Use in a vertical position only (contact point downward).

## Inch

ANSI/AGD type

Graduation	Order No.		Range (range/rev)	Accuracy	Dial reading	Measuring force						—
	w/ lug	Flat-back										
.001"	<b>1921</b>	<b>1921B</b>	.1" (.04")	±.001"	0-20-0	1.8N or less	—	—	—	—	—	—
.0005"	<b>1923</b>	<b>1923B</b>	.05" (.02")	±.0005"	0-10-0	1.8N or less	—	✓	—	—	—	—
.0001"	<b>1927-10</b>	<b>1927B-10</b>	.01" (.004")	±.0002"	0-2-0	1.8N or less	—	✓	—	—	—	—
.0001"	<b>1925-10</b>	<b>1925B-10</b>	.025" (.01")	±.0002"	0-5-0	1.8N or less	—	✓	—	—	—	—
.001"	<b>1410S</b>	<b>1410SB</b>	.25" (.1")	±.001"	0-100	1.4N or less	—	—	—	—	—	—
.001"	<b>1411S</b>	<b>1411SB</b>	.25" (.1")	±.001"	0-50-0	1.4N or less	—	—	—	—	—	—
.001"	<b>1410S-10</b>	<b>1410SB-10</b>	.25" (.1")	±.001"	0-100	1.4N or less	—	✓	—	—	—	—
.001"	<b>1780S</b>	<b>1780SB</b>	.125" (.05")	±.001"	0-50	1.4N or less	—	—	—	—	—	—
.001"	<b>1781S</b>	<b>1781SB</b>	.125" (.05")	±.001"	0-25-0	1.4N or less	—	—	—	—	—	—
.0005"	<b>1506S</b>	<b>1506SB</b>	.125" (.05")	±.0005"	0-50	1.4N or less	—	—	—	—	—	—
.0005"	<b>1507S</b>	<b>1507SB</b>	.125" (.05")	±.0005"	0-25-0	1.4N or less	—	—	—	—	—	—
.0005"	<b>1670S</b>	<b>1670SB</b>	.1" (.04")	±.0005"	0-40	1.4N or less	—	—	—	—	—	—
.0005"	<b>1671S</b>	<b>1671SB</b>	.1" (.04")	±.0005"	0-20-0	1.4N or less	—	—	—	—	—	—
.0005"	<b>1570S</b>	<b>1570SB</b>	.075" (.03")	±.0005"	0-30	1.4N or less	—	✓	—	—	—	—
.0005"	<b>1571S</b>	<b>1571SB</b>	.075" (.03")	±.0005"	0-15-0	1.4N or less	—	✓	—	—	—	—
.00025"	<b>1470S</b>	<b>1470SB</b>	.05" (.02")	±.00025"	0-20	1.4N or less	—	—	—	—	—	—
.00025"	<b>1471S</b>	<b>1471SB</b>	.05" (.02")	±.00025"	0-10-0	1.4N or less	—	—	—	—	—	—
.0001"	<b>1802S-10</b>	<b>1802SB-10</b>	.025" (.01")	±.0001"	0-10	1.4N or less	—	✓	—	—	—	—
.0001"	<b>1803S-10</b>	<b>1803SB-10</b>	.025" (.01")	±.0001"	0-5-0	1.4N or less	—	✓	—	—	—	—



1040S



1041S

1044S  
1044S-10  
1044S-60

1045S



1124S

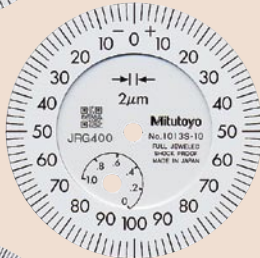

1013S-10

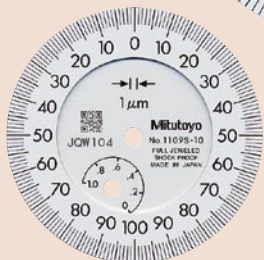

1109S-10

## DIMENSION

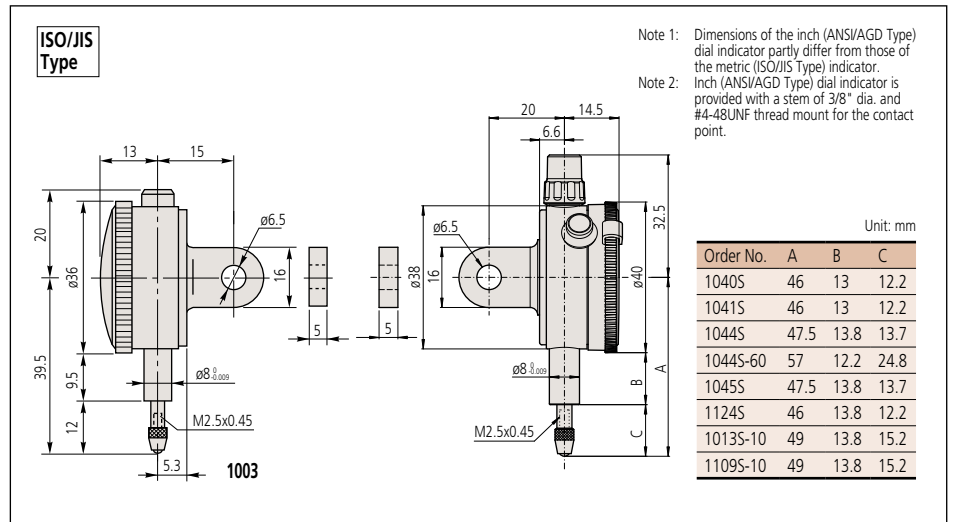

# Dial Indicator

## SERIES 2 — Standard Type, 0.01mm Resolution

Series 2 dial indicators are Mitutoyo's most popular, and have the widest application.

### FEATURES

- Standard 0.01mm graduation dial gauges having an outer frame with an outside diameter of 57mm. All types come with limit pins and an outer frame clamp as standard.
- The outer clamp and lifting lever (optional) can be attached to either the right or left side. These parts can be easily installed and removed without tools.
- Secured adhesion between the outer frame and crystal as well as the use of an O-ring ensure countermeasures against water and oil permeation via the front face.
- The stem spindle is made of high-strength quench-hardened stainless steel which resists strenuous use.
- A carbide contact point is used.
- The grand gear uses stainless steel that is resistant to wear and deformation.
- Application of a hard coating on the surface of the crystal makes the gauge highly scratch- and chemical-resistant.



(Refer to the page 9 for details.)



2046S  
2046SH  
2046S-09  
2046S-15  
2046S-80  
2046SLB



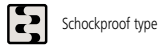

Shockproof type



Waterproof type



Long stem type



Jeweled bearing type



w/ coaxial revolution counter



Reverse reading type

## SPECIFICATIONS

Metric

ISO/JIS type

Graduation	Order No.		Range (range/rev)	Accuracy	Dial reading	Measuring force						
	w/ lug	Flat-back										
0.01mm	2044S	2044SB	5mm (1mm)	±12μm	0-100	1.4N or less	—	—	—	—	—	—
0.01mm	2044S-09	2044SB-09	5mm (1mm)	±13μm	0-100	1.4N or less	✓	—	—	—	—	—
0.01mm	2044S-60	2044SB-60	5mm (1mm)	±12μm	0-100	2.5N or less	—	✓	—	—	—	—
0.01mm	2045S	2045SB	5mm (1mm)	±12μm	0-50-0	1.4N or less	—	—	—	—	—	—
0.01mm	2046S	2046SB	10mm (1mm)	±13μm	0-100	1.4N or less	—	—	—	—	—	—
0.01mm	2046SY	2046SYB	10mm (1mm)	±13μm	0-100	1.4N or less	—	—	—	—	—	—
0.01mm	2046SH	2046SHB	10mm (1mm)	±8μm	0-100	1.4N or less	—	—	—	—	—	—
0.01mm	—	2046SLB	10mm (1mm)	±13μm	0-100	1.4N or less	—	—	✓	—	—	—
0.01mm	2046S-09	2046SB-09	10mm (1mm)	±15μm	0-100	1.4N or less	✓	—	—	—	—	—
0.01mm	2046S-60	2046SB-60	10mm (1mm)	±13μm	0-100	2.5N or less	—	✓	—	—	—	—
0.01mm	2046S-69	2046SB-69	10mm (1mm)	±15μm	0-100	2.5N or less	✓	✓	—	—	—	—
0.01mm	2046S-15	2046SB-15	10mm (1mm)	±13μm	0-100	0.8N or less*	—	—	—	✓	—	—
0.01mm	2310S-10	2310SB-10	10mm (1mm)	±15μm	0-100	1.4N or less	—	—	—	✓	✓	—
0.01mm	2902S	2902SB	10mm (1mm)	±13μm	100-0	1.4N or less	—	—	—	—	—	✓
0.01mm	2047S	2047SB	10mm (1mm)	±13μm	0-50-0	1.4N or less	—	—	—	—	—	—

\*Use in a vertical position only (contact point downward).

## DIMENSION

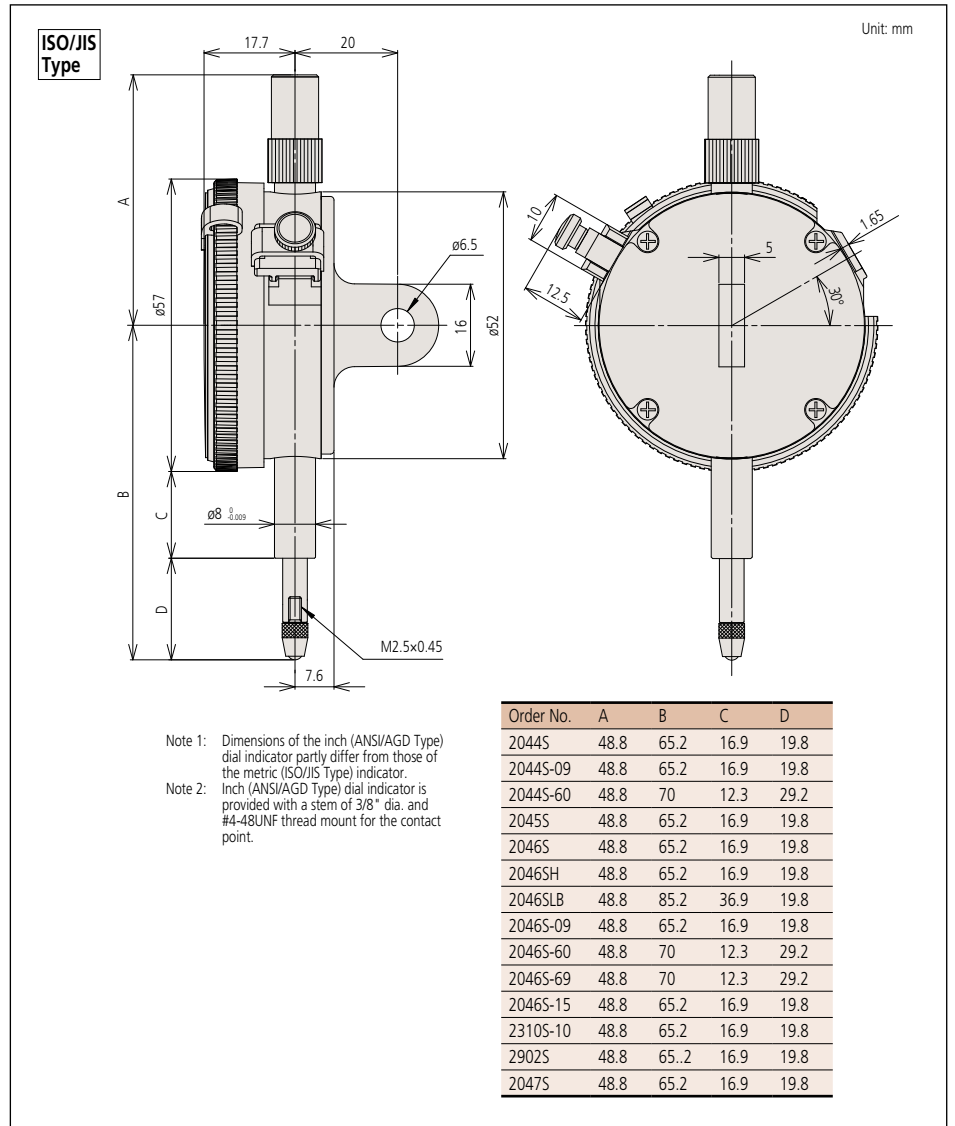

2902S



2310S-10



2044S  
2044S-60  
2044S-09



2045S

### Optional Accessory

- : Backs (See page 266.)
- : Contact points (See page 264.)

# Dial Indicator

## SERIES 2 — Standard Type, 0.001mm Resolution

### FEATURES

- Standard 0.01mm graduation dial gauges having an outer frame with an outside diameter of  $\varnothing 57\text{mm}$ . All types come with limit pins and an outer frame clamp.
- The outer clamp and lifting lever (optional) can be attached to either the right or left side. These parts can be easily installed and removed without tools.
- Secured adhesion between the outer frame and crystal as well as the use of an O-ring ensure countermeasures against water and oil permeation via the front face.
- The stem spindle is made of high-strength quench-hardened stainless steel which resists strenuous use.
- A carbide contact point is used.
- The grand gear uses stainless steel that is resistant to wear and deformation.
- Application of a hard coating on the surface of the crystal makes the gauge highly scratch- and chemical-resistant.
- A special alloy is used for the sector gears to provide improved wear resistance.
- The bearing part uses jeweled bearings, providing excellent indication sensitivity and durability.

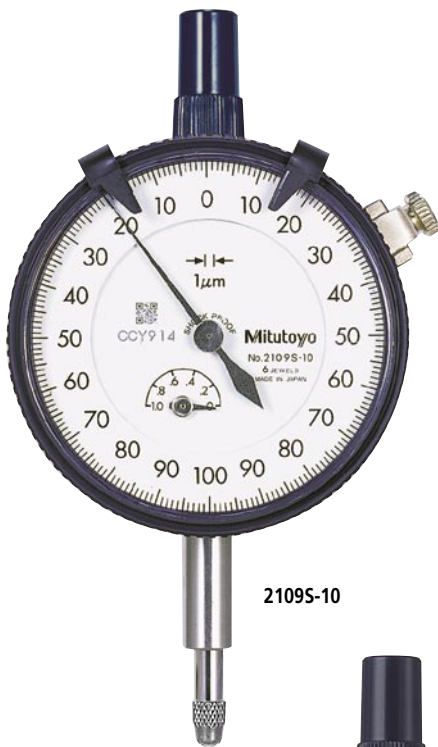

2109S-10



2110S-10



2119S-10



(Refer to the page 9 for details.)

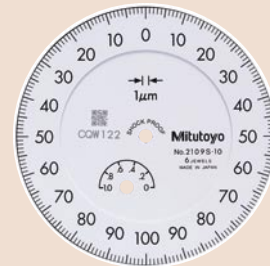

2109S-10  
2109SH-10  
2109S-70  
2109SLB-10



2110S-10  
2110S-70

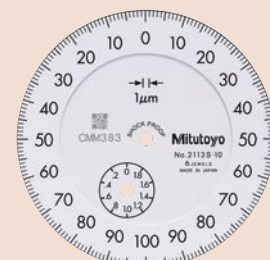





2113S-10



# Dial Indicator

## SERIES 2 — Standard Type, Inch Reading

### SPECIFICATIONS

Graduation	Order No.		Range (range/rev)	Accuracy	Dial reading	Measuring force	ANSI/AGD type					
	w/ lug	Flat-back									—	—
.001"	<b>2780S</b>	<b>2780SB</b>	.125" (.05")	±.001"	0-50	1.8N or less	—	—	—	—	—	—
.001"	<b>2781S</b>	<b>2781SB</b>	.125" (.05")	±.001"	0-25-0	1.8N or less	—	—	—	—	—	—
.001"	<b>2410S</b>	<b>2410SB</b>	.25" (.1")	±.001"	0-100	1.8N or less	—	—	—	—	—	—
.001"	<b>2410S-10</b>	<b>2410SB-10</b>	.25" (.1")	±.001"	0-100	1.8N or less	—	—	—	✓	—	—
.001"	<b>2410S-60</b>	<b>2410SB-60</b>	.25" (.1")	±.001"	0-100	2.5N or less	—	✓	—	—	—	—
.001"	<b>2411S</b>	<b>2411SB</b>	.25" (.1")	±.001"	0-50-0	1.8N or less	—	—	—	—	—	—
.001"	<b>2411S-10</b>	<b>2411SB-10</b>	.25" (.1")	±.001"	0-50-0	1.8N or less	—	—	—	✓	—	—
.001"	<b>2414S</b>	<b>2414SB</b>	.5" (.1")	±.001"	0-100	1.8N or less	—	—	—	—	—	—
.001"	<b>2414S-10</b>	<b>2414SB-10</b>	.5" (.1")	±.001"	0-100	1.8N or less	—	—	—	✓	—	—
.001"	<b>2414S-60</b>	<b>2414SB-60</b>	.5" (.1")	±.001"	0-100	2.5N or less	—	✓	—	—	—	—
.001"	<b>2415S</b>	<b>2415SB</b>	.5" (.1")	±.001"	0-50-0	1.8N or less	—	—	—	—	—	—
.001"	<b>2415S-10</b>	<b>2415SB-10</b>	.5" (.1")	±.001"	0-50-0	1.8N or less	—	—	—	✓	—	—
.001"	<b>2415S-60</b>	<b>2415SB-60</b>	.5" (.1")	±.001"	0-50-0	2.5N or less	—	✓	—	—	—	—
.001"	<b>2914S</b>	<b>2914SB</b>	.5" (.1")	±.001"	100-0	1.8N or less	—	—	✓	—	—	—
.0005"	<b>2506S</b>	<b>2506SB</b>	.125" (.05")	±.0005"	0-50	1.8N or less	—	—	—	—	—	—
.0005"	<b>2507S</b>	<b>2507SB</b>	.125" (.05")	±.0005"	0-25-0	1.8N or less	—	—	—	—	—	—
.0005"	<b>2514S</b>	<b>2514SB</b>	.5" (.05")	±.0015"	0-50	1.8N or less	—	—	—	—	—	—
.0005"	<b>2514S-60</b>	<b>2514SB-60</b>	.5" (.05")	±.0015"	0-50	2.5N or less	—	✓	—	—	—	—
.0005"	<b>2570S-10</b>	<b>2570SB-10</b>	.075" (.03")	±.0005"	0-30	1.8N or less	—	—	—	✓	—	—
.0005"	<b>2571S-10</b>	<b>2571SB-10</b>	.075" (.03")	±.0005"	0-15-0	1.8N or less	—	—	—	✓	—	—
.0005"	<b>2576S-70</b>	<b>2576SB-70</b>	.3" (.03")	±.001"	0-30	2.5N or less	—	✓	—	✓	—	—
.0005"	<b>2670S</b>	<b>2670SB</b>	.1" (.04")	±.0005"	0-40	1.8N or less	—	—	—	—	—	—
.0005"	<b>2671S</b>	<b>2671SB</b>	.1" (.04")	±.0005"	0-20-0	1.8N or less	—	—	—	—	—	—
.0005"	<b>2675S</b>	<b>2675SB</b>	.4" (.04")	±.0015"	0-20-0	1.8N or less	—	—	—	—	—	—
.0005"	<b>2922S</b>	<b>2922SB</b>	.125" (.05")	±.0005"	0-25-0	1.8N or less	—	—	—	—	—	—
.00025"	<b>2470S-10</b>	<b>2470SB-10</b>	.05" (.02")	±.00025"	0-20	1.8N or less	—	—	—	✓	—	—
.00025"	<b>2471S-10</b>	<b>2471SB-10</b>	.05" (.02")	±.0005"	0-10-0	1.8N or less	—	—	—	✓	—	—
.00025"	<b>2476S-70</b>	<b>2476SB-70</b>	.2" (.02")	±.0005"	0-20	2.5N or less	—	✓	—	✓	—	—
.0001"	<b>2356S-10</b>	<b>2356SB-10</b>	.25" (.01")	±.0008"	0-10	2.0N or less	—	—	—	✓	—	—
.0001"	<b>2358S-10</b>	<b>2358SB-10</b>	.5" (.01")	±.0002"	0-10	2.0N or less	—	—	—	✓	—	—
.0001"	<b>2802S-10</b>	<b>2802SB-10</b>	.025" (.01")	±.0001"	0-10	2.0N or less	✓	—	—	✓	—	—
.0001"	<b>2802S-70</b>	<b>2802SB-70</b>	.025" (.01")	±.0001"	0-10	2.5N or less	✓	✓	—	✓	—	—
.0001"	<b>2803S-10</b>	<b>2803SB-10</b>	.025" (.01")	±.0001"	0-5-0	2.0N or less	✓	—	—	✓	—	—
.0001"	<b>2803S-70</b>	<b>2803SB-70</b>	.025" (.01")	±.0001"	0-5-0	2.5N or less	✓	✓	—	✓	—	—
.0001"	<b>2804S-10</b>	<b>2804SB-10</b>	.05" (.01")	±.0002"	0-10	2.0N or less	✓	—	—	✓	—	—
.0001"	<b>2805S-10</b>	<b>2805SB-10</b>	.05" (.01")	±.0002"	0-5-0	2.0N or less	✓	—	—	✓	—	—
.0001"	<b>2806S-10</b>	<b>2806SB-10</b>	.1" (.01")	±.0003"	0-10	2.0N or less	✓	—	—	✓	—	—
.0001"	<b>2806S-70</b>	<b>2806SB-70</b>	.1" (.01")	±.0003"	0-10	2.5N or less	✓	✓	—	✓	—	—
.0001"	<b>2905S-10</b>	<b>2905SB-10</b>	.05" (.01")	±.0002"	10-0	2.0N or less	✓	—	✓	✓	—	—
.0001"	<b>2923S-10</b>	<b>2923SB-10</b>	.05" (.01")	±.0002"	0-5-0	2.0N or less	✓	—	—	✓	—	—
.0001"	<b>2937S-10</b>	<b>2937SB-10</b>	.02" (.008")	±.0001"	0-4-0	2.0N or less	✓	—	—	✓	—	—
.0001"	<b>2938S-10</b>	<b>2938SB-10</b>	.02" (.008")	±.0001"	0-8	2.0N or less	✓	—	—	✓	—	—



(Refer to the page 9 for details.)

### Optional Accessory

- : Backs (See page 266.)
- : Contact points (See page 264.)

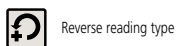
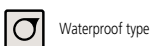

# Special Dial Indicator

## SERIES 2



(Refer to the page 9 for details.)

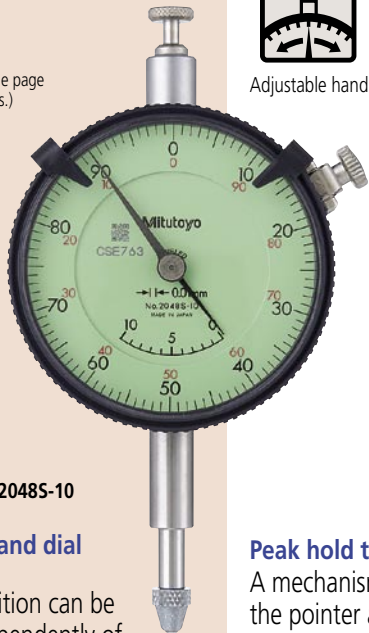

20485-10

### Adjustable hand dial gauge

The hand position can be adjusted independently of the vertical movement of the spindle by rotating the top knob.



Adjustable hand



20465-80

### Peak hold type dial gauge

A mechanism that stops the pointer and the spindle at the depressed position where the spindle is depressed makes the pointer stop and display the maximum value.



Peak hold



29405

### Double-face type dial gauge

The displacement of the spindle can be read from either the front or rear face.



Double-face type

### Optional Accessory

- : Backs (See page 266.)
- : Contact points (See page 264.)

### SPECIFICATIONS

Metric				ISO/JIS type				ANSI/AGD type			
Graduation	Order No.		Range (range/rev)	Accuracy	Dial reading	Measuring force	Measuring force	ISO/JIS type		ANSI/AGD type	
	w/ lug	Flat-back									
0.01mm	20485-10	20485B-10	10mm (1mm)	±15µm	0-100	1.4N or less	Adjustable hand				
0.01mm	20485-11	20485B-11	10mm (1mm)	±13µm	0-100	1.4N or less	Adjustable hand				
0.01mm	20465-80	20465B-80	10mm (1mm)	±15µm	0-100	5.0N or less	Peak hold				
0.01mm	29405	—	10mm (1mm)	±15µm	0-100	3.0N or less	Double-face				

Inch				ANSI/AGD type							
Graduation	Order No.		Range (range/rev)	Accuracy	Dial reading	Measuring force	Remarks	ISO/JIS type		ANSI/AGD type	
	w/ lug	Flat-back									
.001"	29155-10	29155B-10	.5" (.1")	±.001"	0-100	1.8N or less	Jeweled bearing, adjustable hand				
.001"	29185-10	29185B-10	.5" (.1")	±.001"	0-50-0	1.8N or less	Jeweled bearing, adjustable hand				

### DIMENSION

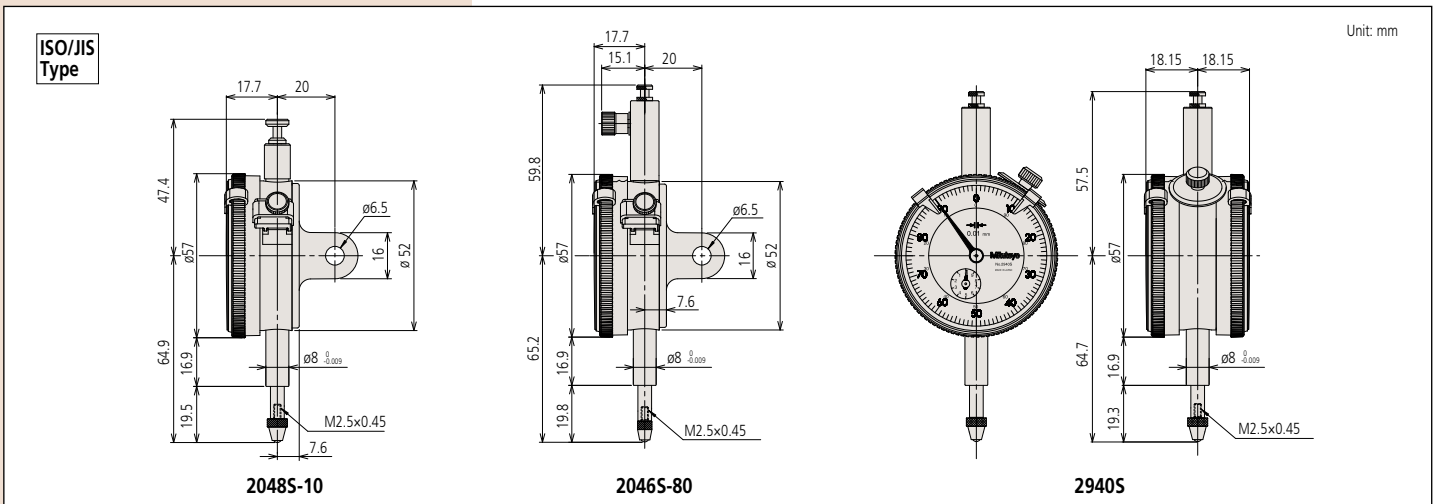

# Dial Indicator

## SERIES 2 — Standard One Revolution Type for Error-free Reading

Unlike many other dial indicators, the one-revolution dial indicator literally shows the entire spindle travel or range as one sweep of the hand, eliminating the possibility of reading errors due to miscounting the multiple revolutions. With one-revolution dial indicators, "within tolerance" and "out-of-tolerance" can never be misinterpreted.

### FEATURES

- An unique shock-proof mechanism is incorporated, providing improved immunity to shock due to sudden spindle retraction caused by high impact.

- The crystal is hard coated for durability and scratch resistance.
- Approximately 40% lighter than the conventional dial indicator.
- Provided with an improved resistance to shop floor contaminants such as water and dust.
- Due to the spindle bushing being offset from the stem, spindle movement will not be hindered or jammed when clamping along the stem.
- A pair of limit hands are provided for quick and easy tolerance judgment (GO/±NG).

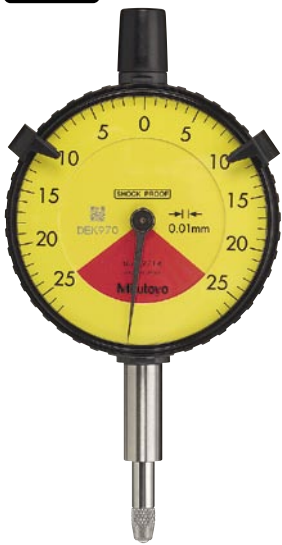

2971

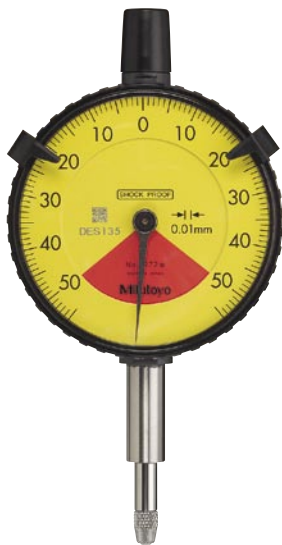

2972

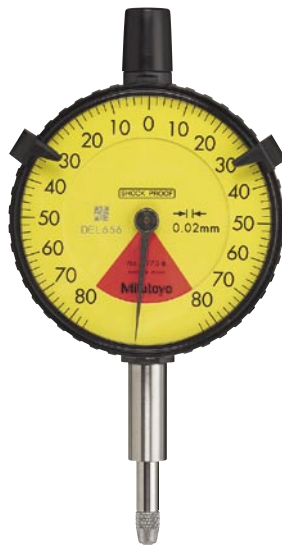

2973

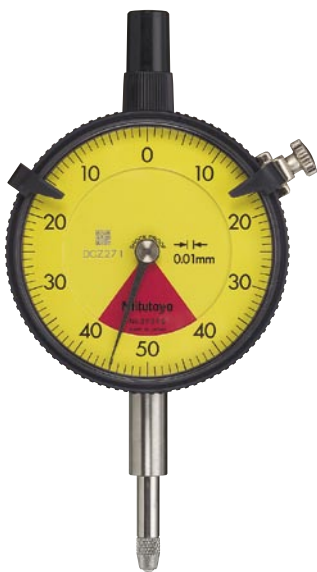

29295

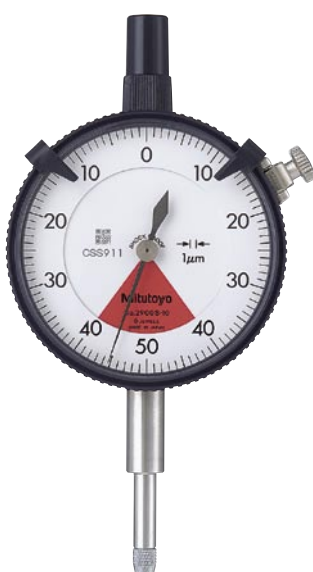

29005-10



2990



(Refer to the page 9 for details.)

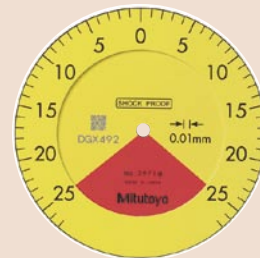

2971



2972

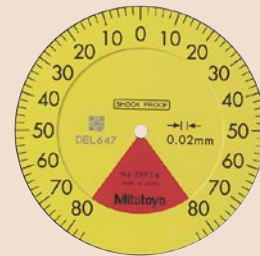

2973



29285



Shockproof type



Waterproof type



Dustproof type



Jeweled bearing type

## SPECIFICATIONS

## Metric

ISO/JIS type

Graduation	Order No.		Range (range/full stroke)	Accuracy	Dial reading	Measuring force					—
	w/ lug	Flat-back									
0.1mm	2928S	2928SB	4mm / 10mm	±40µm	2-0-2	1.4N or less	✓	—	—	—	—
0.01mm	2929S	2929SB	0.8mm / 1mm	±9µm	40-0-40	1.4N or less	✓	—	—	—	—
0.01mm	2929S-60	2929SB-60	0.8mm / 1mm	±9µm	40-0-40	2.0N or less	✓	✓	—	—	—
0.01mm	2929S-62	2929SB-62	0.8mm / 1mm	±9µm	40-0-40	2.0N or less	✓	—	✓	—	—
0.01mm	2959S	2959SB	1.6mm / 2mm	±13µm	80-0-80	1.4N or less	✓	—	—	—	—
0.001mm	2900S-10	2900SB-10	0.08mm / 0.1mm	±3µm	40-0-40	1.4N or less	✓	—	—	✓	—
0.001mm	2900S-70	2900SB-70	0.08mm / 0.1mm	±3µm	40-0-40	2.0N or less	✓	✓	—	✓	—
0.001mm	2900S-72	2900SB-72	0.08mm / 0.1mm	±3µm	40-0-40	2.0N or less	✓	—	✓	✓	—
0.001mm	2901S-10	2901SB-10	0.16mm / 0.2mm	±4µm	80-0-80	1.4N or less	✓	—	—	✓	—
0.02mm	—	2973	1.6mm / 2mm	±16µm	80-0-80	1.4N or less	✓	—	✓	—	—
0.01mm	—	2971	0.5mm / 0.7mm	±10µm	25-0-25	1.4N or less	✓	—	✓	—	—
0.01mm	—	2972	1mm / 1.4mm	±12µm	50-0-50	1.4N or less	✓	—	✓	—	—
0.01mm	2990*	—	0.1mm / 0.14mm	±6.5µm	50-0-50	1.5N or less	✓	—	—	✓	—
0.001mm	—	2960F*	1mm / 1.27mm	±14µm	50-0-50	1.4N or less	✓	—	—	—	—

\*Back plunger type (see page 262.)

## Inch

ANSI/ASD type

Graduation	Order No.		Range (range/full stroke)	Accuracy	Dial reading	Measuring force					—
	w/ lug	Flat-back									
.001"	2908S	2908SB	.08" / .1"	±.001"	40-0-40	1.8N or less	✓	—	—	—	—
.001"	2908S-62	2908SB-62	.08" / .1"	±.001"	40-0-40	2.5N or less	✓	✓	—	—	—
.0005"	2909S-62	2909SB-62	.04" / .05"	±.0005"	20-0--20	2.5N or less	✓	✓	—	—	—
.0001"	2910S-10	2910SB-10	.008" / .01"	±.0001"	4-0-4	1.8N or less	✓	—	✓	—	—
.0001"	2910S-72	2910SB-72	.008" / .01"	±.0001"	4-0-4	2.5N or less	✓	—	✓	—	—
.001"	—	2978	.06" / .079"	±.001"	30-0-30	1.4N or less	✓	✓	—	—	—
.0005"	—	2976	.02" / .028"	±.0005"	10-0-10	1.4N or less	✓	✓	—	—	—
.0005"	—	2977	.04" / .055"	±.0005"	20-0-20	1.4N or less	✓	✓	—	—	—
.0001"	—	2991*	.008" / .01"	±.0002"	4-0-4	1.5N or less	✓	—	✓	—	—

\*Back plunger type (see page 262.)

2929S  
2929S-60  
2929S-62

2959S

2900S-10  
2900S-70  
2900S-72

2901S-10

## DIMENSION

ISO/JIS Type

Unit: mm

Note 1: Dimensions of the inch (ANSI/ASD Type) dial indicator partly differ from those of the metric (ISO/JIS Type) indicator.

Note 2: Inch (ANSI/ASD Type) dial indicator is provided with a stem of 3/8" dia. and #4-48UNF thread mount for the contact point.

Order No.	A	B	C	D	E	F	G	H	I
2971	43.2	65.6	55.6	16.2	—	21	16.8	55	7.6
2972	43.2	66.0	55.6	16.2	—	21	17.2	55	7.6
2973	43.2	66.3	55.6	16.2	—	21	17.5	55	7.6
2929S	48.8	65.2	57	17.7	20	12.3	29.2	52	7.6
2929S-62	48.8	65.2	57	17.7	20	16.9	19.8	52	7.6
2929S-60	48.8	70	57	17.7	20	12.3	29.2	52	7.6
2959S	48.8	65.2	57	17.7	20	16.9	19.8	52	7.6
2900S-10	48.8	66	57	17.7	20	16.9	20.6	52	7.6
2900S-72	48.8	66	57	17.7	20	16.9	20.6	52	7.6
2900S-70	48.8	67	57	17.7	20	12.3	26.2	52	7.6
2901S-10	48.8	66.1	57	17.7	20	16.9	20.7	52	7.6
2928S	48.8	65.2	57	17.7	20	16.9	19.8	52	7.6

## Optional Accessory

- : Backs (See page 266.)
- : Contact points (See page 264.)

# Dial Indicator

## SERIES 2 — Long Stroke Type



2050S



2052S



2330S-10



(Refer to the page 9 for details.)



2050S-60  
2050S  
2050S-19



2052S  
2052S-19

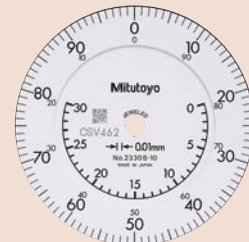

2330S-10



2320S-10



2952S



Shockproof type



Waterproof type



w/ damper at lowest rest point



Jeweled bearing type



w/ coaxial revolution counter



Reverse reading type

## SPECIFICATIONS

### Metric

ISO/JIS type

Graduation	Order No.		Range (range/rev)	Accuracy	Dial reading	Measuring force						
	w/ lug	Flat-back										
0.01mm	<b>2050S</b>	<b>2050SB</b>	20mm (1mm)	±20μm	0-100	2.0N or less	—	—	✓	—	—	—
0.01mm	<b>2050S-60</b>	<b>2050SB-60</b>	20mm (1mm)	±20μm	0-100	2.5N or less	—	✓	—	—	—	—
0.01mm	<b>2050S-19</b>	<b>2050SB-19</b>	20mm (1mm)	±20μm	0-100	2.0N or less	✓	—	✓	✓	—	—
0.01mm	<b>2320S-10</b>	<b>2320SB-10</b>	20mm (1mm)	±20μm	0-100	2.0N or less	—	—	✓	✓	✓	—
0.01mm	<b>2052S</b>	<b>2052SB</b>	30mm (1mm)	±25μm	0-100	2.5N or less	—	—	✓	—	—	—
0.01mm	<b>2052S-19</b>	<b>2052SB-19</b>	30mm (1mm)	±25μm	0-100	2.5N or less	✓	—	✓	✓	—	—
0.01mm	<b>2330S-10</b>	<b>2330SB-10</b>	30mm (1mm)	±25μm	0-100	2.5N or less	—	—	✓	✓	✓	—
0.01mm	<b>2952S</b>	<b>2952SB</b>	30mm (1mm)	±25μm	100-0	2.5N or less	—	—	✓	—	—	✓

### Inch

ANSI/AGD type

Graduation	Order No.		Range (range/rev)	Accuracy	Dial reading	Measuring force						
	w/ lug	Flat-back										
.01"	<b>2204S</b>	<b>2204SB</b>	1" (1")	±.005"	0-1000	1.8N or less	—	—	—	—	—	—
.001"	<b>2416S</b>	<b>2416SB</b>	1" (.1")	±.001"	0-100	1.8N or less	—	—	—	—	—	—
.001"	<b>2416S-06</b>	<b>2416SB-06</b>	1" (.1")	±.001"	0-100	1.8N or less	—	—	—	—	—	—
.001"	<b>2416S-10</b>	<b>2416SB-10</b>	1" (.1")	±.001"	0-100	1.8N or less	—	—	—	✓	—	—
.001"	<b>2416S-60</b>	<b>2416SB-60</b>	1" (.1")	±.001"	0-100	2.5N or less	—	✓	—	—	—	—
.001"	<b>2417S</b>	<b>2417SB</b>	1" (.1")	±.001"	0-50-0	1.8N or less	—	—	—	—	—	—
.001"	<b>2424S-19</b>	<b>2424SB-19</b>	2" (.1")	±.003"	0-100	2.5N or less	✓	—	—	✓	—	✓
.0005"	<b>2776S</b>	<b>2776SB</b>	1" (.05")	±.002"	0-50	1.8N or less	—	—	—	—	—	—
.0005"	<b>2776S-60</b>	<b>2776SB-60</b>	1" (.05")	±.002"	0-50	2.5N or less	—	✓	—	—	—	—
.001"	<b>2904S</b>	<b>2904SB</b>	1" (.1")	±.002"	100-0	2.0N or less	—	—	✓	—	—	—

### Optional Accessory

- : Backs (See page 266.)
- : Contact points (See page 264.)

## DIMENSION

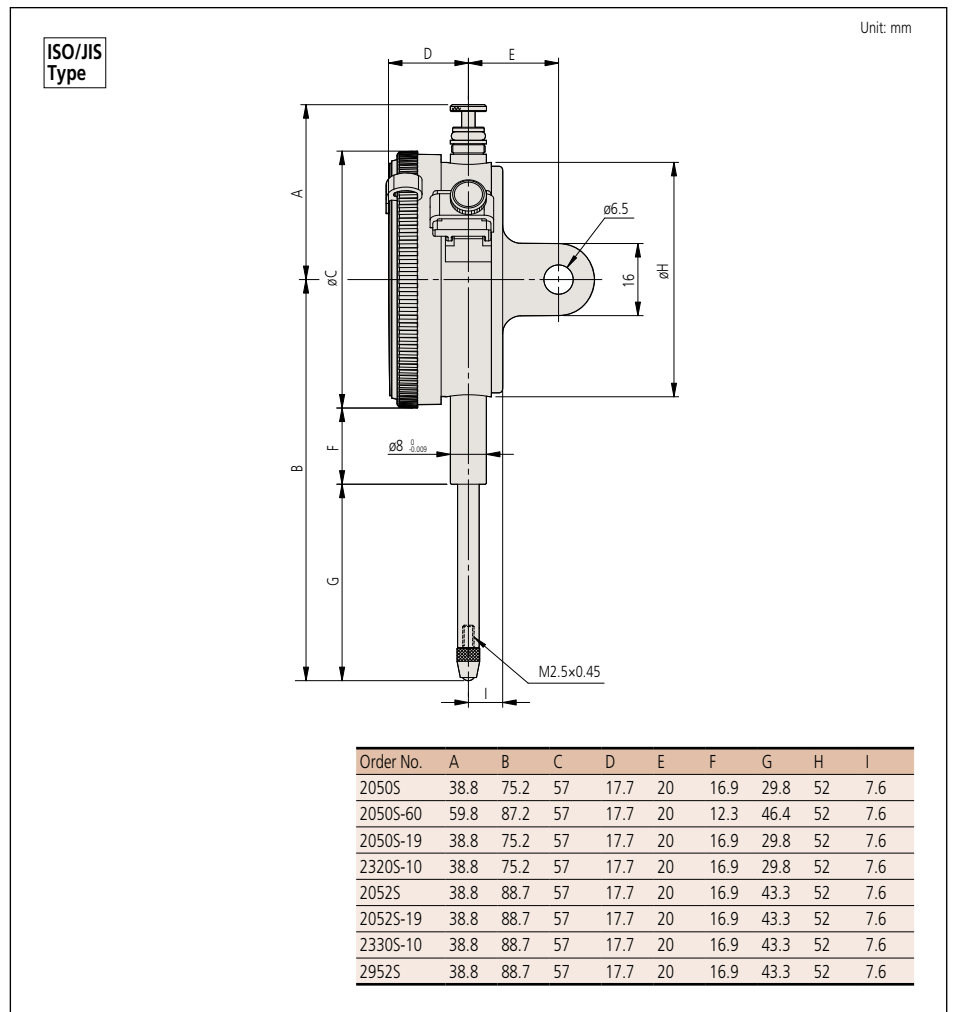

# Dial Indicator

## SERIES 3, 4 — Large Dial Face and Long Stroke Type

- Dial gauges with a large-diameter graduation face to ease reading.
- All types come with limit pins and an outer frame clamp as standard.



3109S-10

3058S-19

4046S



(Refer to the page 9 for details.)



3046S



3047S



3050S

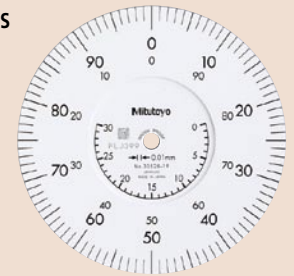

3052S-19

## DIMENSION

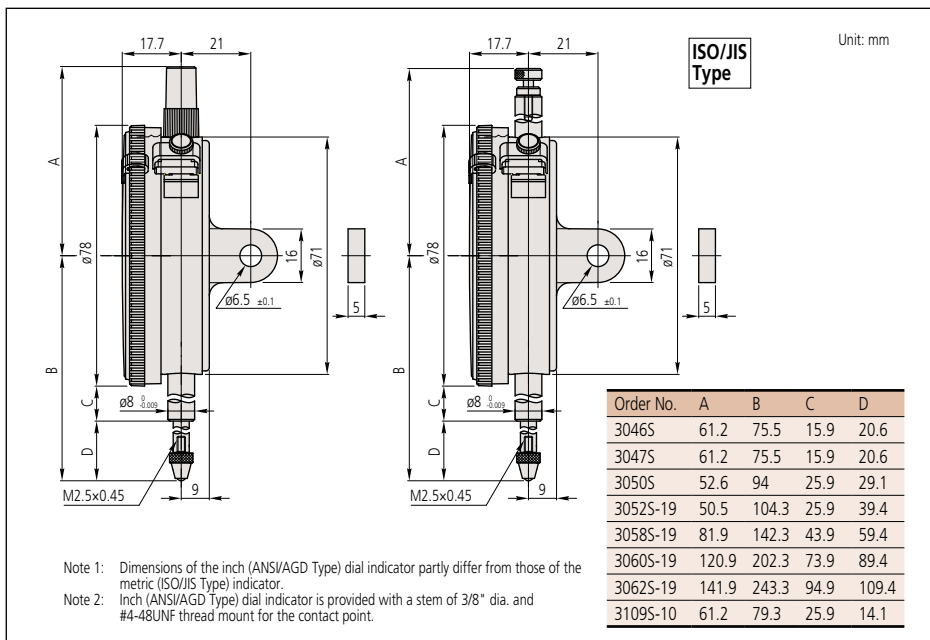



Shockproof type



w/ damper at lowest rest point



Jeweled bearing type



w/ coaxial revolution counter

## SPECIFICATIONS

### Metric

ISO/JIS type    ANSI/AGD type

Graduation	Order No.		Range (range/rev)	Accuracy	Dial reading	Measuring force						
	w/ lug	Flat-back									—	—
0.01mm	<b>3046S</b>	<b>3046SB</b>	10mm (1mm)	±15µm	0-100	1.4N or less	—	—	—	—	—	—
0.01mm	<b>3047S</b>	<b>3047SB</b>	10mm (1mm)	±15µm	0-50-0	1.4N or less	—	—	—	—	—	—
0.01mm	<b>3050S</b>	<b>3050SB</b>	20mm (1mm)	±20µm	0-100	2.0N or less	—	✓	—	—	—	—
0.01mm	<b>3052S-19</b>	<b>3052SB-19</b>	30mm (1mm)	±25µm	0-100	2.5N or less	✓	—	✓	✓	—	—
0.01mm	<b>3052S-11</b>	<b>3052SB-11</b>	30mm (1mm)	±30µm	0-100	2.5N or less	—	—	✓	✓	—	—
0.01mm	<b>3058S-19</b>	<b>3058SB-19</b>	50mm (1mm)	±30µm	0-100	3.0N or less	✓	—	✓	✓	—	—
0.01mm	<b>3058S-11</b>	<b>3058SB-11</b>	50mm (1mm)	±40µm	0-100	3.0N or less	—	—	✓	✓	—	—
0.01mm	<b>3060S-19*</b>	<b>3060SB-19*</b>	80mm (1mm)	±45µm	0-100	3.0N or less	✓	—	✓	✓	—	—
0.01mm	<b>3062S-19*</b>	<b>3062SB-19*</b>	100mm (1mm)	±50µm	0-100	3.2N or less	✓	—	✓	✓	—	—
0.001mm	<b>3109S-10</b>	<b>3109SB-10</b>	1mm (0.2mm)	±6µm	0-100-0	1.5N or less	✓	—	✓	—	—	—
0.01mm	<b>4046S</b>	<b>4046SB</b>	10mm (1mm)	±15µm	0-100	1.4N or less	—	—	—	—	—	—

\*Use in a vertical position only.

### Inch

ANSI/AGD type

Graduation	Order No.		Range (range/rev)	Accuracy	Dial reading	Measuring force					
	w/ lug	Flat-back								—	—
.001"	<b>3414S</b>	<b>3414SB</b>	.5" (.1")	±.001"	0-100	1.8N or less	—	—	—	—	—
.001"	<b>3415S</b>	<b>3415SB</b>	.5" (.1")	±.001"	0-50-0	1.8N or less	—	—	—	—	—
.001"	<b>3416S</b>	<b>3416SB</b>	1" (.1")	±.002"	0-100	1.8N or less	—	—	—	—	—
.001"	<b>3417S</b>	<b>3417SB</b>	1" (.1")	±.002"	0-50-0	1.8N or less	—	—	—	—	—
.001"	<b>3424S-19</b>	<b>3424SB-19</b>	2" (.1")	±.003"	0-100	3.0N or less	✓	✓	✓	—	—
.001"	<b>3426S-19</b>	<b>3426SB-19</b>	3" (.1")	±.005"	0-100	3.0N or less	✓	✓	✓	—	—
.001"	<b>3428S-19</b>	<b>3428SB-19</b>	4" (.1")	±.005"	0-100	3.2N or less	✓	✓	✓	—	—
.0005"	<b>3570S-10</b>	<b>3570SB-10</b>	.075" (.03")	±.0005"	0-30	1.8N or less	—	✓	—	—	—
.0005"	<b>3571S-10</b>	<b>3571SB-10</b>	.075" (.03")	±.0005"	0-15-0	1.8N or less	—	✓	—	—	—
.0001"	<b>3802S-10</b>	<b>3802SB-10</b>	.025" (.01")	±.0001"	0-10	2.0N or less	✓	✓	—	—	—
.0001"	<b>3803S-10</b>	<b>3803SB-10</b>	.025" (.01")	±.0001"	0-5-0	2.0N or less	✓	✓	—	—	—
.001"	<b>4410S</b>	<b>4410SB</b>	.25" (.1")	±.001"	0-100	1.8N or less	—	—	—	—	—
.001"	<b>4887S-19</b>	<b>4887SB-19</b>	3" (.1")	±.005"	0-100	3.0N or less	✓	✓	✓	—	—
.0005"	<b>4570S-10</b>	<b>4570SB-10</b>	.075" (.03")	±.0005"	0-30	1.8N or less	—	✓	—	—	—
.0001"	<b>4802S-10</b>	<b>4802SB-10</b>	.025" (.01")	±.0001"	0-10	2.0N or less	✓	✓	—	—	—
.0001"	<b>4803S-10</b>	<b>4803SB-10</b>	.025" (.01")	±.0001"	0-5-0	2.0N or less	✓	✓	—	—	—



3058S-19



3060S-19



3062S-19

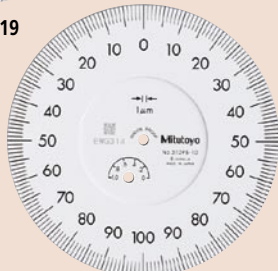

3109S-10



4046S

## DIMENSION

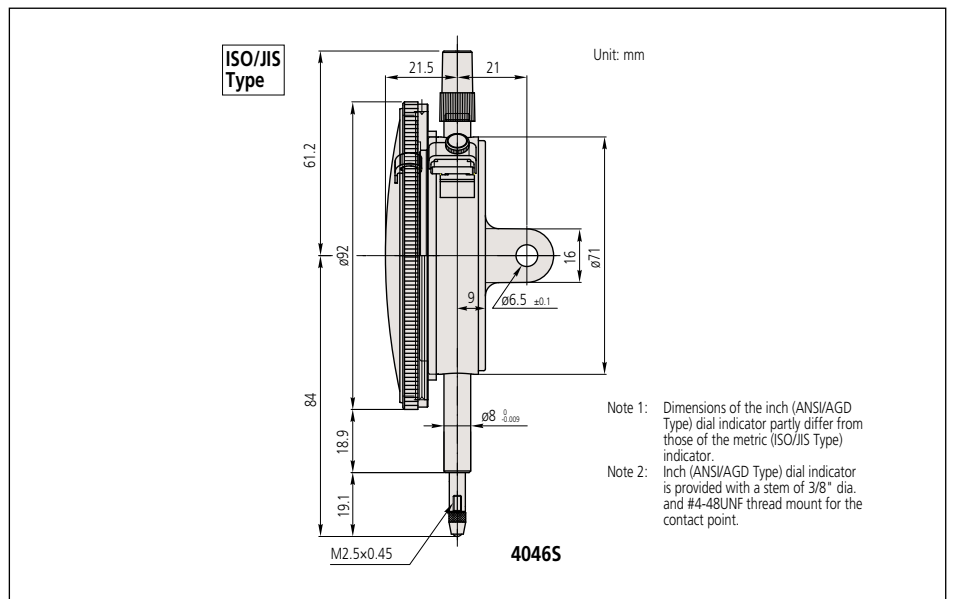

### Optional Accessory

—: Contact points (See page 262.)

# ANSI/AGD Type Metric Dial Indicator

with 3/8" DIA. Stem and #4-48UNF-Thread Contact Point Compatible Type

## SPECIFICATIONS

**Metric** Series 1  ANSI/AGD type

Graduation	Order No.		Range (range/rev)	Accuracy	Dial reading	Measuring force							
	w/ lug	Flat-back											
0.01mm	<b>1230S-01</b>	<b>1230SB-01</b>	2.5mm (1mm)	±10µm	0-100	1.5N or less	—	—	—	—	—	—	—
0.01mm	<b>1231S-01</b>	<b>1231SB-01</b>	2.5mm (1mm)	±10µm	0-50-0	1.5N or less	—	—	—	—	—	—	—
0.01mm	<b>1044S-01</b>	<b>1044SB-01</b>	5mm (1mm)	±10µm	0-100	1.4N or less	—	—	—	—	—	—	—
0.01mm	<b>1045S-01</b>	<b>1045SB-01</b>	5mm (1mm)	±10µm	0-50-0	1.4N or less	—	—	—	—	—	—	—
0.002mm	<b>1010S-11</b>	<b>1010SB-11</b>	0.5mm (0.2mm)	±2µm	0-20	1.5N or less	—	✓	—	—	—	—	—
0.002mm	<b>1011S-11</b>	<b>1011SB-11</b>	0.5mm (0.2mm)	±2µm	0-10-0	1.5N or less	—	✓	—	—	—	—	—



(Refer to the page 9 for details.)

**Metric** Series 2  ANSI/AGD type

Graduation	Order No.		Range (range/rev)	Accuracy	Dial reading	Measuring force							
	w/ lug	Flat-back											
0.01mm	<b>2230S-01</b>	<b>2230SB-01</b>	2.5mm (1mm)	±10µm	0-100	1.4N or less	—	—	—	—	—	—	—
0.01mm	<b>2231S-01</b>	<b>2231SB-01</b>	2.5mm (1mm)	±10µm	0-100	1.4N or less	—	—	—	—	—	—	—
0.01mm	<b>2231S-11</b>	<b>2231SB-11</b>	2.5mm (1mm)	±10µm	0-50-0	1.4N or less	—	✓	—	—	—	—	—
0.01mm	<b>2046S-01</b>	<b>2046SB-01</b>	10mm (1mm)	±13µm	0-100	1.4N or less	—	—	—	—	—	—	—
0.01mm	<b>2046S-11</b>	<b>2046SB-11</b>	10mm (1mm)	±13µm	0-100	1.4N or less	—	✓	—	—	—	—	—
0.01mm	<b>2046S-61</b>	<b>2046SB-61</b>	10mm (1mm)	±13µm	0-100	2.5N or less	✓	—	—	—	—	—	—
0.01mm	<b>2048S-11</b>	<b>2048SB-11</b>	10mm (1mm)	±13µm	0-100	1.4N or less	—	✓	✓	✓	—	—	—
0.01mm	<b>2047S-01</b>	<b>2047SB-01</b>	10mm (1mm)	±13µm	0-50-0	1.4N or less	—	—	—	—	—	—	—
0.01mm	<b>2047S-11</b>	<b>2047SB-11</b>	10mm (1mm)	±13µm	0-50-0	1.4N or less	—	✓	—	—	—	—	—
0.01mm	<b>2902S-01</b>	<b>2902SB-01</b>	10mm (1mm)	±13µm	100-0	1.4N or less	—	—	—	—	—	—	—
0.01mm	<b>2050S-01</b>	<b>2050SB-01</b>	20mm (1mm)	±20µm	0-100	2.0N or less	—	—	—	—	—	—	—
0.01mm	<b>2050S-11</b>	<b>2050SB-11</b>	20mm (1mm)	±20µm	0-100	2.0N or less	—	✓	—	—	—	—	—
0.01mm	<b>2056S-01</b>	<b>2056SB-01</b>	25mm (1mm)	±25µm	0-100	2.5N or less	—	—	—	—	—	—	—
0.002mm	<b>2010S-11</b>	<b>2010SB-11</b>	0.5mm (0.2mm)	±3µm	0-20	1.5N or less	—	✓	—	—	✓	—	—
0.002mm	<b>2010S-71</b>	<b>2010SB-71</b>	0.5mm (0.2mm)	±3µm	0-20	2.5N or less	✓	✓	—	—	—	—	—
0.002mm	<b>2011S-11</b>	<b>2011SB-11</b>	0.5mm (0.2mm)	±3µm	0-10-0	1.5N or less	—	✓	—	—	✓	—	—
0.001mm	<b>2900S-73*</b>	<b>2900SB-73*</b>	0.08mm (0.1mm)	±2µm	40-0-40	1.4N or less	—	✓	—	—	✓	✓	—
0.001mm	<b>2109S-11</b>	<b>2109SB-11</b>	1mm (0.2mm)	±4µm	0-10-0	1.5N or less	—	✓	—	—	✓	—	—
0.001mm	<b>2119S-11</b>	<b>2119SB-11</b>	5mm (0.2mm)	±10µm	0-10-0	1.5N or less	—	✓	—	—	—	—	—

\*One revolution type

**Metric** Series 3  ANSI/AGD type

Graduation	Order No.		Range (range/rev)	Accuracy	Dial reading	Measuring force							
	w/ lug	Flat-back											
0.01mm	<b>3052S-11</b>	<b>3052SB-11</b>	30mm (1mm)	±30µm	0-100	2.5N or less	✓	✓	✓	—	—	—	—
0.01mm	<b>3058S-11</b>	<b>3058SB-11</b>	50mm (1mm)	±40µm	0-100	3.0N or less	✓	✓	✓	—	—	—	—

- Waterproof type
- Jeweled bearing type
- Adjustable hand type
- w/ coaxial revolution counter
- Schockproof type
- Dustproof type
- Double scale spacing type

# Hicator, Signal Hicator

## SERIES 524 — High Accuracy One-Revolution Dial Indicator

### FEATURES

The Hicator is Mitutoyo's ultra-sensitive, one-revolution dial indicator. The spindle is made of highly durable stainless steel, and this device features jeweled bearings for extreme sensitivity as well as a shock-proof and dust-proof structure.

- The maximum, minimum, or runout value can be displayed during measurement.

- The Hicator is capable of probing measurements up to 0.0005mm.
- Connected to an optional Signal Box, the Signal Hicator can output limit signals to perform GO/±NO-GO judgment.
- Splash-proof structure.
- Lug-on-center back is optional.



Hicator  
524-501

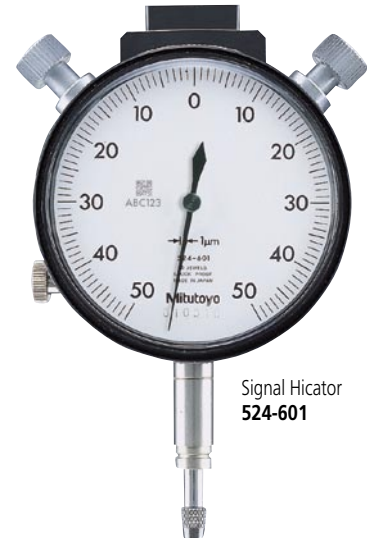

Signal Hicator  
524-601

### Optional Accessory

- 524-001: Signal box (100V AC)
- 524-001A: Signal box (120V AC)
- : Backs (See page 266.)
- : Contact points (See page 264.)

## ABSOLUTE Digimatic Indicator ID-C

### SERIES 543 — with Green/Red LED and GO/NG Signal Output Function



### FEATURES (See page 237.)

- With the max./min. value holding function, the signal ID-C can output the signal of the GO/±NG judgment result against the peak values set. Substitute for the mechanical/electrical contact, the judgment is carried out by calculating the measurement data obtained. This provides high reliability with no deterioration of the contact point and volume adjustment.

### SPECIFICATIONS

Metric		Hicator						ISO/JIS type
Graduation	Order No.*	Range	Dial reading	Spindle travel	Accuracy	Measuring force	Remarks	
0.001mm	524-501	±0.05mm	50-0-50	3mm	±1μm	1.2N or less	w/ spindle lifting cable	
0.0005mm	524-500	±0.03mm	30-0-30	3mm	±0.5μm	1.2N or less	w/ spindle lifting cable	

\*Flat back

Metric		Signal Hicator						ISO/JIS type
Graduation	Order No.*	Range	Dial reading	Spindle stroke	Accuracy	Measuring force	Remarks	
0.01mm	524-603	±0.5mm	50-0-50	3mm	±5μm	1.2N or less	w/ 2m signal cable	
0.002mm	524-602	±0.1mm	100-0-100	3mm	±1.5μm	1.2N or less	w/ 2m signal cable	
0.001mm	524-601	±0.05mm	50-0-50	3mm	±1μm	1.2N or less	w/ 2m signal cable	

\*Flat back

### DIMENSION

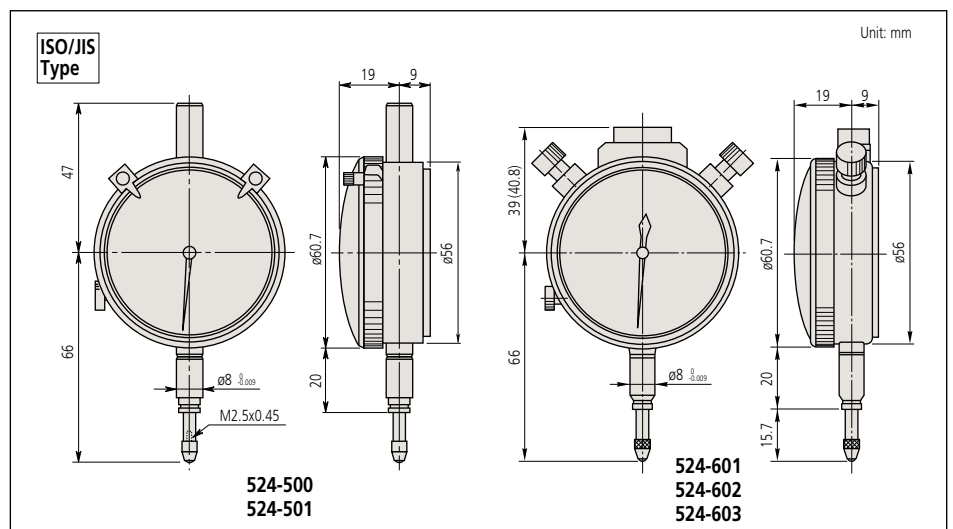

# Back Plunger Type Dial Indicator

## SERIES 1 and 2

Mitutoyo's back plunger type dial indicators are built with the measuring spindles on the back of the units. This type of indicator offers the same precision and durability as all other Mitutoyo dial indicators, and operates very effectively with optional holding bars.

- Back plunger type dial gauges are suitable for mounting onto leveling machine tool tables or inspection jigs, and for use in small spaces where the graduations of standard dial gauges are difficult to see.
- Model No. 1960, which uses Mitutoyo's proprietary shock-proofing mechanism, has excellent durability and shock resistance.
- Model No. 2990 is back plunger type and allows 0.001mm readings.



(Refer to the page 9 for details.)



1160



1960



1180-6

Holding bar (optional)



2960F



2990

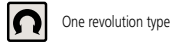

One revolution type



Shockproof type



Jeweled bearing type

## SPECIFICATIONS

**Metric** Series 1

ISO/JIS type

Graduation	Order No.	Range (range/rev)	Accuracy	Dial reading	Measuring force						
0.01mm	<b>1960</b>	1mm / 1.27mm*	±14μm	50-0-50	1.4N or less	✓	✓	—	—	—	—
0.01mm	<b>1160</b>	5mm (1mm)	±16μm	0-100	1.4N or less	—	—	—	—	—	—
0.01mm	<b>1162</b>	5mm (1mm)	±16μm	100-0	1.4N or less	—	—	✓	—	—	—
0.01mm	<b>1180-6</b>	5mm (1mm)	±16μm	0-100	1.5N or less	—	—	—	—	—	—
0.01mm	<b>1180-7</b>	5mm (1mm)	±16μm	0-100	1.5N or less	—	—	—	—	—	—
0.01mm	<b>1180-8</b>	5mm (1mm)	±16μm	0-100	1.5N or less	—	—	—	—	—	—

**Inch** Series 1

ANSI/AGD type

Graduation	Order No.	Range (range/rev)	Accuracy	Dial reading	Measuring force						
.001"	<b>1961</b>	.04" / .05"*	±.001"	20-0-20	1.4N or less	✓	✓	—	—	—	—
.001"	<b>1156</b>	.1" (.1")	±.001"	0-100	2.1N or less	—	—	—	—	—	—
.001"	<b>1157</b>	.1" (.1")	±.001"	0-50-0	2.1N or less	—	—	—	—	—	—
.001"	<b>1166</b>	.2" (.05")	±.001"	0-50	1.4N or less	—	—	—	—	—	—
.001"	<b>1167</b>	.2" (.05")	±.001"	0-25-0	1.4N or less	—	—	—	—	—	—
.001"	<b>1168</b>	.2" (.05")	±.001"	50-0	1.4N or less	—	—	✓	—	—	—

\*Full stroke

**Metric** Series 2

ISO/JIS type

Graduation	Order No.	Range (range/full stroke)	Accuracy	Dial reading	Measuring force						
0.01mm	<b>2960F</b>	1mm / 1.27"	±14μm	50-0-50	1.4N or less	✓	✓	—	—	—	—
0.001mm	<b>2990</b>	0.1mm / 0.14"	±6.5μm	50-0-50	1.5N or less	✓	✓	✓	—	—	—

**Inch** Series 2

ANSI/AGD type

Graduation	Order No.	Range (range/full stroke)	Accuracy	Dial reading	Measuring force						
.0005"	<b>2961</b>	.04" / .05"	±.0005"	20-0-20	1.8N or less	✓	✓	—	—	—	—
.0001"	<b>2991</b>	.008" / .01"	±.0002"	4-0-4	1.5N or less	✓	✓	✓	—	—	—

### Optional Accessory

- 136567:** Holding bar (ø6mm, L=81mm)
- 21AAA166:** Holding bar (ø6mm, L=42mm)
- 136568:** Holding bar (ø8mm, L=81mm)
- 21AAA168:** Holding bar (ø8mm, L=42mm)
- 124625:** Holding bar (.25" DIA, L=3.19")
- 21AAA167:** Holding bar (.25" DIA, L=1.65")
- : Backs (See page 266.)
- : Contact points (See page 264.)

## DIMENSION

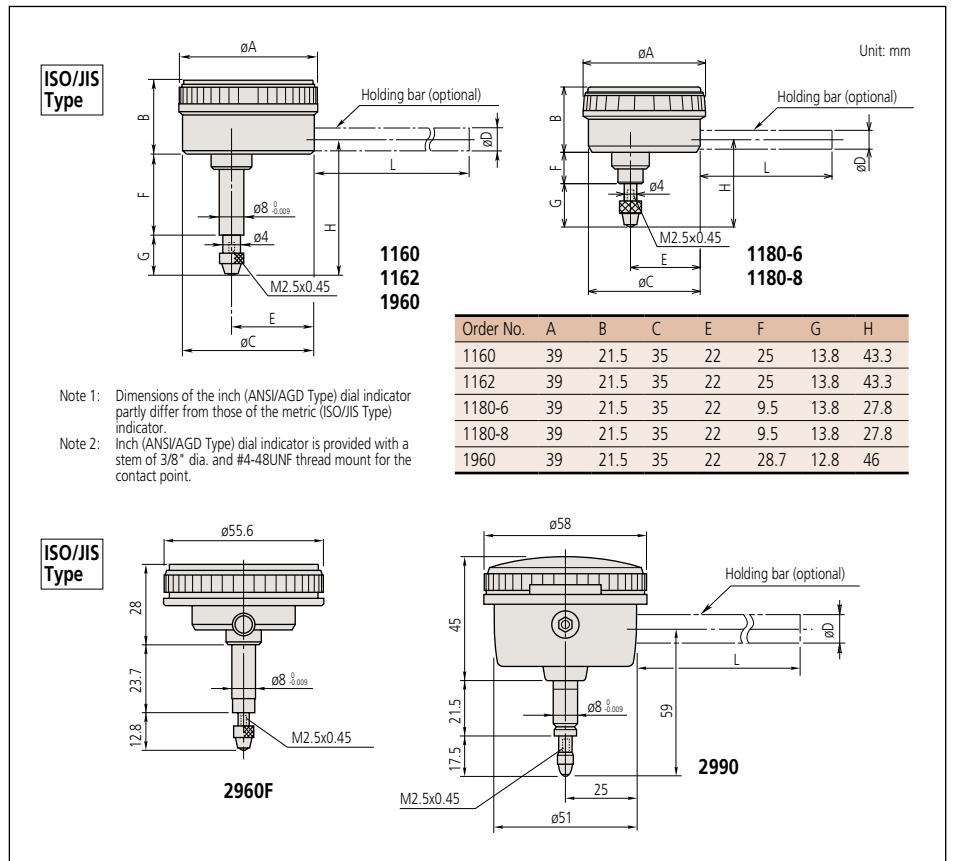

# Contact Point

Optional Accessory for Digimatic and Dial Indicators and Linear Gages

## SPECIFICATIONS

### Ball Points

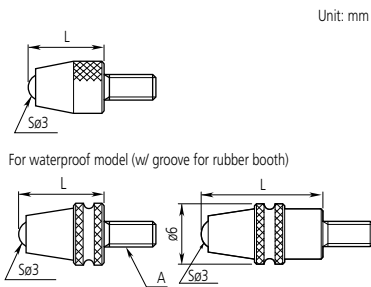

L	Material	Order No.	A
7.3	Carbide	901312	M2.5x0.45
		901454	#4-48UNF
	Plastic	901994	M2.5x0.45
		902018	#4-48UNF
	Ruby	120047	M2.5x0.45
8.3	Carbide	21AZA319	M2.5x0.45
8.3*	Carbide	902119	M2.5x0.45
12.1*	Carbide	21AZA320	M2.5x0.45
14	Carbide	21JAA225	M2.5x0.45
15	Carbide	120049	M2.5x0.45
	Ruby	120051	M2.5x0.45
17	Carbide	21JAA224	M2.5x0.45
19.3*	Carbide	21AZA321	M2.5x0.45
20	Carbide	137391	M2.5x0.45
	Ruby	137392	M2.5x0.45
22	Carbide	21JAA226	M2.5x0.45
25	Carbide	120053	M2.5x0.45
	Ruby	120055	M2.5x0.45
30	Carbide	21AAA252	M2.5x0.45
	Ruby	21AAA253	M2.5x0.45

\*For waterproof dial indicators

### Shell Type Points

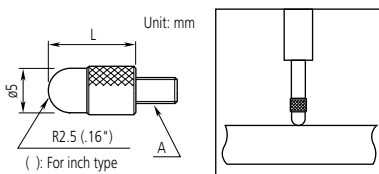

L	Order No.	A
3.97	101184	#4-48UNF
5	101386	M2.5x0.45
10	101118	M2.5x0.45
12.7	101185	#4-48UNF
15	137393	M2.5x0.45
19.05	101186	#4-48UNF
20	101387	M2.5x0.45
25	101388	M2.5x0.45
25.4	101187	#4-48UNF
30	21AAA254	M2.5x0.45

### Ball Point

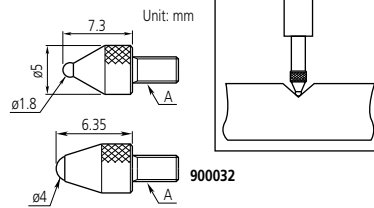

SφD	ød	Order No.	A
1mm, carbide	5mm	21AAA349	M2.5x0.45
1.5mm, carbide	5mm	21AAA350	M2.5x0.45
1.8mm, steel	5mm	101122	M2.5x0.45
2.5mm, carbide	5mm	21AAA351	M2.5x0.45
4mm, carbide	5mm	21AAA352	M2.5x0.45
4mm, carbide	5mm	900032	#4-48UNF

### Spherical Points

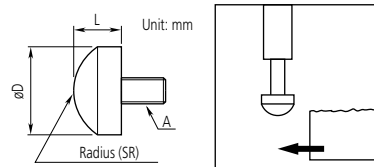

D	L	SR	Order No.	A
10	5	7	101119	M2.5x0.45
12.7	3.18	7	101205	#4-48UNF
9.53	2.38	9	101204	#4-48UNF

### Spherical Points (Carbide)

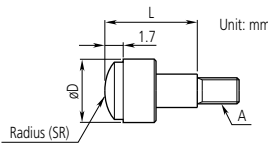

D	L	SR	Order No.	A
5.2	5	5	120058	M2.5x0.45
7.5	10	7	120059	M2.5x0.45
10.5	10	10	120060	M2.5x0.45

### Conical Points

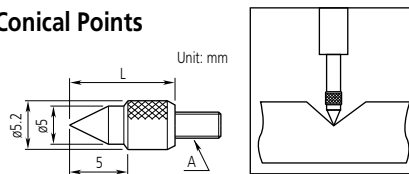

Tip angle	L	Order No.	A
60°	10	101120	M2.5x0.45
60°	12.7	101190	#4-48UNF

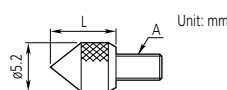

Tip angle	L	Order No.	A
90°	5	101385	M2.5x0.45
90°	7.14	101191	#4-48UNF

### Conical Points (Carbide)

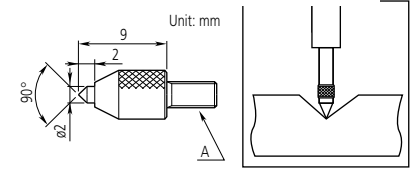

Order No.	A
120057	M2.5x0.45

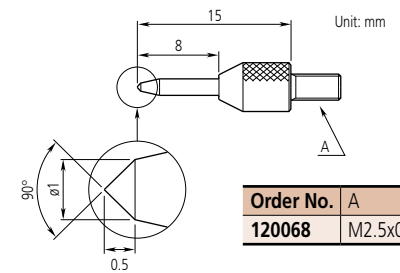

Order No.	A
120068	M2.5x0.45

### Knife Edge Point (Carbide)

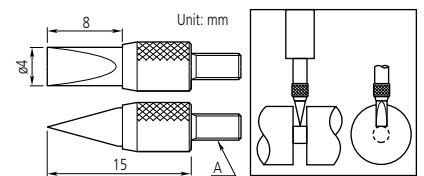

Order No.	A
120067	M2.5x0.45

### Flat Points

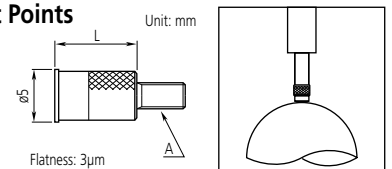

L	Order No.	A
8	131365	M2.5x0.45
10	21AAA340	M2.5x0.45
8	133017	#4-48UNF

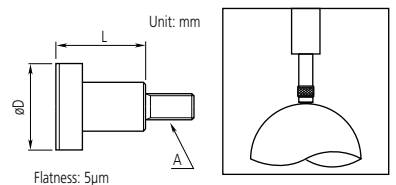

D	L	Order No.	A
10	10	101117	M2.5x0.45
15	10	21AAA341	M2.5x0.45
20	10	21AAA342	M2.5x0.45
25	10	21AAA343	M2.5x0.45
20	10	21AAA344	M2.5x0.45
12.7	9.53	101188	#4-48UNF
9.53	9.53	101189	#4-48UNF

### Flat Points (Carbide)

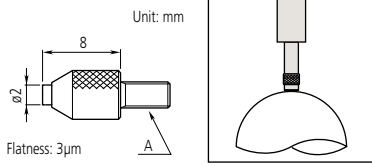

Order No.	A
120056	M2.5x0.45

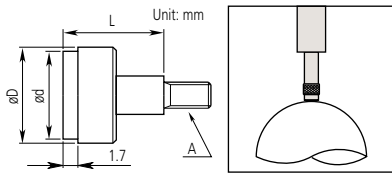

D	d	L	Order No.	A
5.2	4.3*	5	120041	M2.5x0.45
7	6.5*	10	120042	M2.5x0.45
10.5	9.5*	10	120043	M2.5x0.45
17	15**	10	21AAA345	M2.5x0.45
22	20**	10	21AAA346	M2.5x0.45
27	25**	10	21AAA347	M2.5x0.45
32	30**	10	21AAA348	M2.5x0.45

Flatness: \*3µm, \*\*5µm

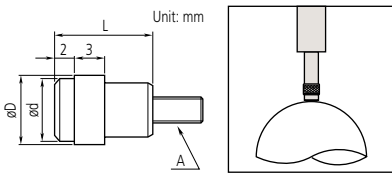

D	d	L	Order No.	A
7	6.4	10	137255	M2.5x0.45
9	8	10	137399	M2.5x0.45

### Lever Points

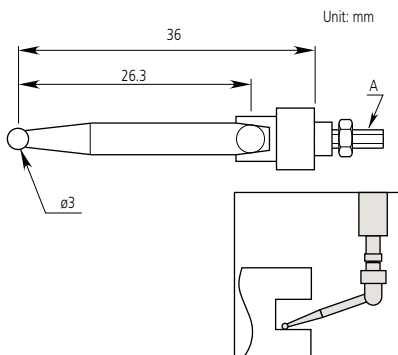

Order No.	A
900391	M2.5x0.45
900393	#4-48UNF

### Lever Points

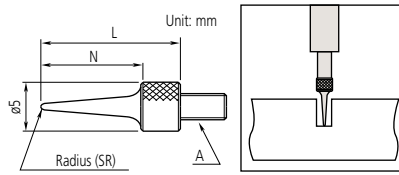

N	L	SR	Order No.	A
11	15	0.4	101121	M2.5x0.45
13	17	0.2	137413	M2.5x0.45
21	25	0.4	21AAA255	M2.5x0.45
31	35	0.4	21AAA256	M2.5x0.45

### Needle Points (Carbide)

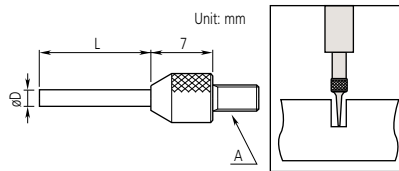

D	L	Order No.	A
0.45	3	120066	M2.5x0.45
0.45	5	21AAA329	M2.5x0.45
1	3	120065	M2.5x0.45
1	5	21AAA330	M2.5x0.45
1	8	21AAA331	M2.5x0.45
1	10	21AAA332	M2.5x0.45
1	20	21AAA333	M2.5x0.45
1	40	21AAA334	M2.5x0.45
1.5	5	21AAA335	M2.5x0.45
1.5	10	21AAA336	M2.5x0.45
1.5	13	120064	M2.5x0.45
1.5	20	21AAA337	M2.5x0.45
1.5	40	21AAA338	M2.5x0.45
2	8	137257	M2.5x0.45
2	18	21AAA257	M2.5x0.45
2	28	21AAA258	M2.5x0.45
2	40	21AAA339	M2.5x0.45

### Blade Points (Carbide)

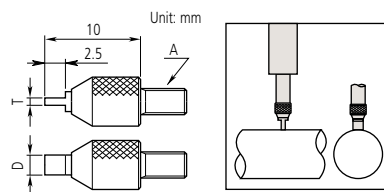

T	W	Order No.	A
0.4	2	120061	M2.5x0.45
0.6	2	120062	M2.5x0.45
1	4	120063	M2.5x0.45

### Roller Points

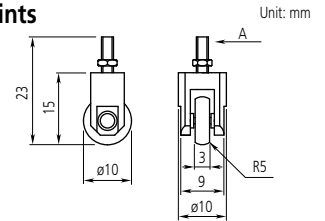

Order No.	A
901954	M2.5x0.45
901991	#4-48UNF

### Extension Rods

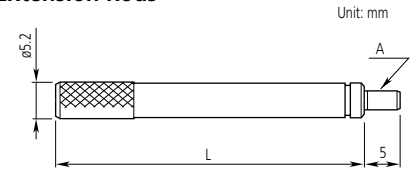

L	Order No.	A
10	303611	M2.5x0.45
15	21AAA259A	M2.5x0.45
20	303612	M2.5x0.45
25	21AAA259B	M2.5x0.45
30	303613	M2.5x0.45
35	21AAA259C	M2.5x0.45
40	21AAA259D	M2.5x0.45
45	21AAA259E	M2.5x0.45
50	21AAA259F	M2.5x0.45
55	21AAA259G	M2.5x0.45
60	304146	M2.5x0.45
65	21AAA259H	M2.5x0.45
70	21AAA259J	M2.5x0.45
75	21AAA259L	M2.5x0.45
80	21AAA259M	M2.5x0.45
90	304147	M2.5x0.45
100	303614	M2.5x0.45
1"	301655	#4-48UNF
2"	301657	#4-48UNF
4"	301659	#4-48UNF

### Interchangeable Contact Point Set (M2.5x0.45)













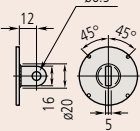

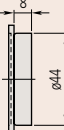

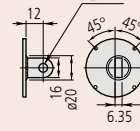

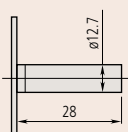
Order No.	Components
7822	Flat Point (131365, $\phi 5$ mm)
	Flat Point (101117, $\phi 10$ mm)
	Needle Point (101121)
	Spherical Point (101119)
	Shell Type Point (101118)
	Shell Type Point (101387)

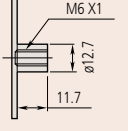
# Back

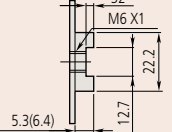
## Optional Accessory for Digimatic and Dial Indicators

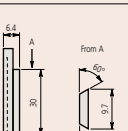
### SPECIFICATIONS

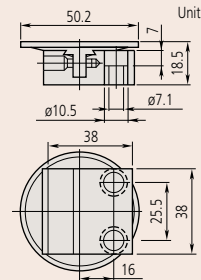
Description	Unit: mm	Order No.		
		Series 1 (ø41mm)	Series 2 (ø57mm)	Series 3, 4 (ø77, 91mm)
Flat Back 		<b>101211:</b> a=2.2 <b>136872:</b> for water-proof type <b>191559:</b> for 1911, 1913-10 <b>137906:</b> for 1003	<b>101039:</b> a=2.5 <b>21AZB231:</b> for water-proof of S type	<b>100836:</b> a=3.0
Lug-on-Center Back 		<b>101210:</b> metric type <b>101307:</b> inch type <b>190561:</b> for 1911, 1913-10 <b>137905:</b> for 1003	<b>101040:</b> metric type <b>101306:</b> inch type <b>21AZB230:</b> for water-proof of S type	<b>100691:</b> metric type <b>100797:</b> inch type
Magnetic Back 		<b>Special order</b>	<b>900928</b>	<b>900929</b>
Back with Offset Lug 		<b>Special order</b>	<b>101167</b>	<b>100837</b>
Back with Post 		<b>193172</b> Order-to-made	<b>101169</b>	<b>100839</b>
Back with Screw Mount 		<b>193173:</b> M6x1, Order-to-made <b>193174:</b> #1/4-28UNF, Order-to-made	<b>136023:</b> M6x1 <b>193174:</b> #1/4-28UNF	<b>136024:</b> M6x1 <b>100840:</b> #1/4-28UNF
Adjustable Back 		<b>136025:</b> M6x1 <b>129721:</b> #1/4-28UNF	<b>136026:</b> M6x1 <b>101168:</b> #1/4-28UNF)	<b>136027:</b> M6x1 <b>100838:</b> #1/4-28UNF
Back with Dovetail 		—	<b>900008</b>	<b>Special order</b>
Back with Adjustable Bracket 		—	<b>901963</b>	—

There are two ways to support Digimatic and dial indicators; by either holding the stem or the lug on the back of the indicator. The back of the indicator may need to be replaced for special applications. A wide variety of backs are available for Mitutoyo Digimatic and dial indicators.

### Application

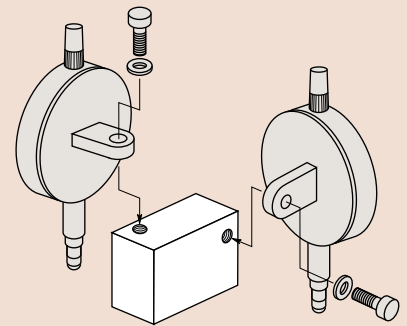

# Spindle Lifting Lever and Cable

## Optional Accessory for Digimatic and Dial Indicators

### Spindle Lifting Lever

- The Spindle Lifting Lever is attached to the top end of the spindle for improved inspection efficiency when using a dial indicator mounted on a stand.

#### 21BZA205

Use for Series 1 dial indicators.



#### 21AZB149

Use for S type Series 2, 3, and 4 dial indicators (up to 10mm/.4").



#### 21AZB150

Use for S type Series 2 and 3 dial indicators (from 10mm/.4" up to 20mm/.8").



### Spindle Lifting Cable

901975: with auto-stop function

540774: without auto-stop function

Lifting range: 10mm

Cable length: 300mm



### Spindle Lifting Knob

137693

Applicable spindle diameter; 4.8mm



### Application

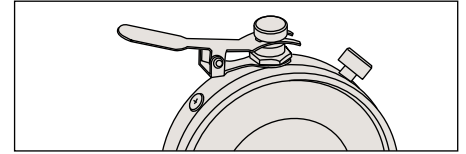
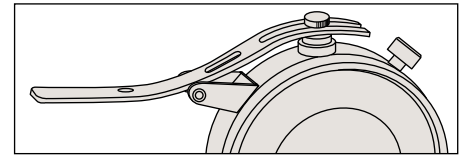

#### 902011

Use for Series 2 dial indicators (up to 10mm/.4" range).



#### 902100

Use for Series 2 dial indicators (up to 10mm/.4" range).



#### 903424

Use for Series 2 dial indicators (up to 20mm/.8" range) and Series 3 and 4 dial indicators (up to 10mm/.4" range).



### Application

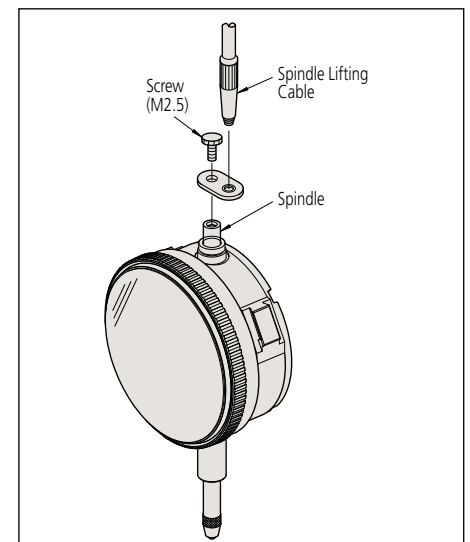

# Color Spindle Cap

## Optional Accessory for Digimatic and Dial Indicators

8 colors of spindle caps are available for dial indicators with a range of 10mm or less.

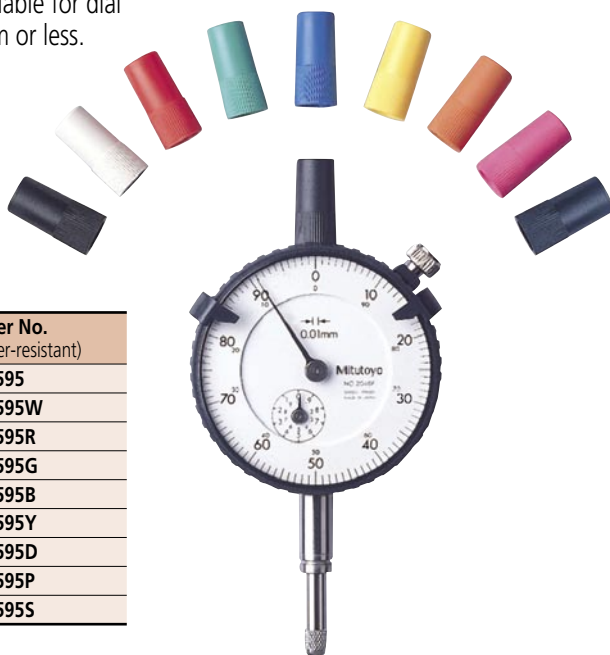

### SPECIFICATIONS

Color	Order No. (normal)	Order No. (water-resistant)
Black	193051	193595
White	193051W	193595W
Red	193051R	193595R
Green	193051G	193595G
Blue	193051B	193595B
Yellow	193051Y	193595Y
Orange	193051D	193595D
Pink	193051P	193595P
Dark blue	193051S	193595S

# Limit Sticker

## Optional Accessory for Digimatic and Dial Indicators

### FEATURES

- Stuck on the dial face or crystal of a Series 2 dial indicator (55.6mm or 57mm bezel dia.) to indicate tolerance limits.



136420: Red (10-sheet/set)



136421: Green (10-sheet/set)



136422: Yellow (10-sheet/set)

# Dial Indicator Repair Tool Kit

Optional Accessory for Digimatic and Dial Indicators

## Set Configuration

- 901171: Molykote (lubricant)
- 901172: Lubricating oil
- 901173: Screwdriver (Phillips)
- 901174: Screwdriver (Phillips/flat blade)
- 129729: Tweezers
- 901175: Pin-vise
- 901176: Brush
- 901177: Brush
- 901177: Brush
- 901178: Hammer
- 129730: Spindle rest
- 129731: Pin rest
- 901179: Nippers
- 901180: Pliers
- 901181: Hand remover
- 129732: Pin remover
- 129733: Punch
- 129734: Bearing adjuster
- 129735: Pinion rest
- 129736: Reamer  $\varnothing 1$
- 193702: Reamer  $\varnothing 0.6$
- 901182: Case

Mitutoyo offers a tool set designed to let you perform simple repairs to your Mitutoyo dial indicator, and a device that lets you reset the indicator crystals.



7823

# Dial Indicator Crystal Setter

Optional Accessory for Digimatic and Dial Indicators

## FEATURES

- Used for fitting a crystal on dial indicators, dial test indicators, and dial calipers.



7000

With 8 sizes of crystal setting pads







# Dial Test Indicator

## SERIES 513

### FEATURES

- Narrow or deep places, which cannot be measured with a normal dial gauge, can be easily and accurately measured.
- Mitutoyo's proprietary new structure permits smooth pointer operation.
- Use of a hard frame body provides excellent rigidity and durability.
- Non-magnetic pointer and contact point permit secure operation even in environments with magnetism.
- Use of a clear and concise wide dial face allows excellent visibility.
- The surface of the crystal is hard-coated, to make it scratch-resistant.
- Flat crystal makes gradations easy to read. Moreover, the unified structure of the outer frame prevents oil and water from permeating via the front face.
- Six types are available: vertical, inclined, perpendicular, horizontal, universal, and pocketable, allowing users to select the model most suited to their needs.
- Vertical: Standard
- Inclined: Dial face inclined 20°, compared with the vertical type, allows easy reading.
- Perpendicular: Best suited for centering holes.
- Horizontal: The graduations can be read from the front, with the probe on the tip of the horizontal conical rod abutting the workpiece.
- Universal: The direction of the probe movement can be freely changed.
- Pocketable: Compact type

### Description of Icon

Icon	Description
	With revolution counter type
	Long contact point type
	Jeweled bearing type
	Double scale spacing type, easy-on-the-eyes
	Compact type
	Dustproof type
	Anti-magnetic type

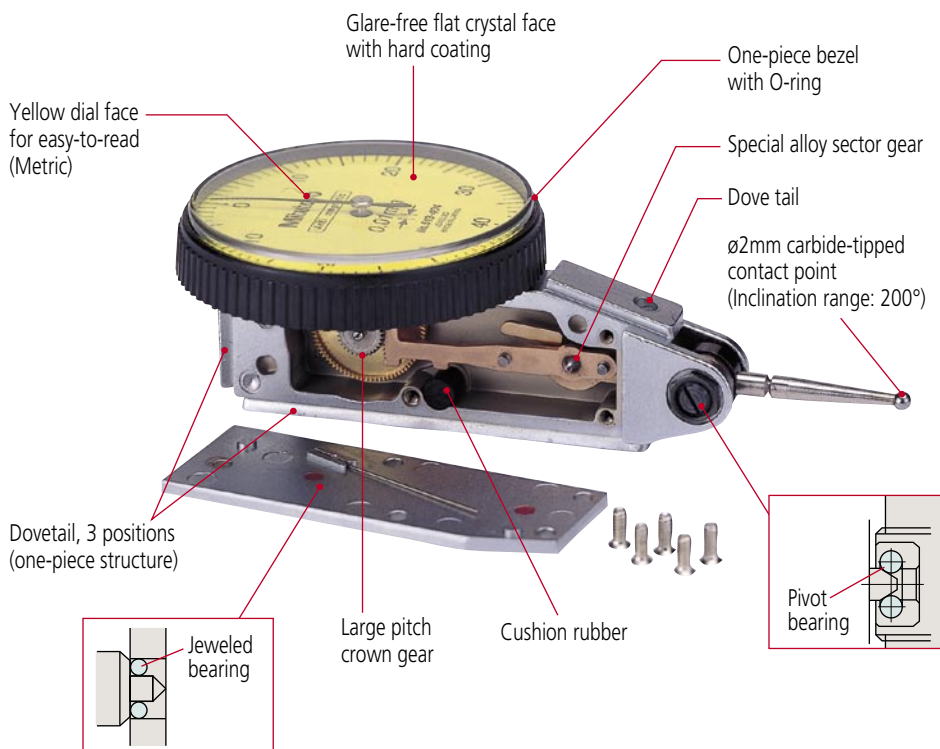

# Dial Test Indicator

## SERIES 513 — Universal Type

### Set Configuration: Metric

#### Full set

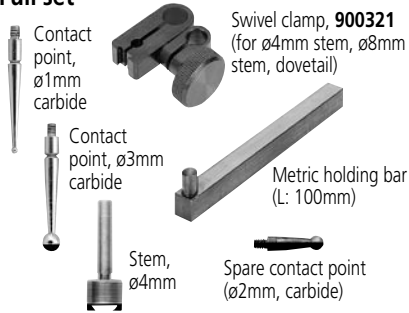

#### Basic set

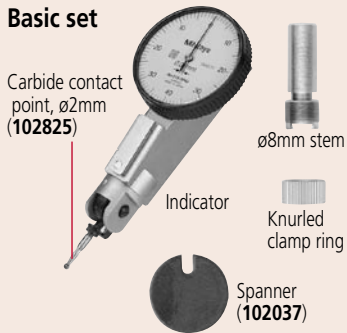

### Set Configuration: Inch

#### Full set

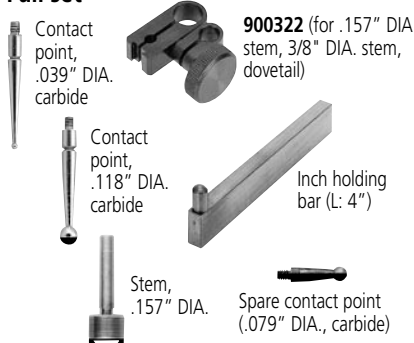

#### Basic set

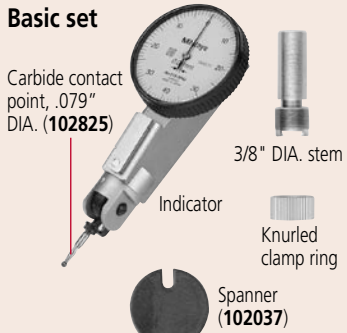

### Optional Accessory

- : Swivel clamp (See page 278.)
- : Holding bar (See page 278.)
- : Stem (See page 278.)
- 102824:** Contact point, ø1mm ball (carbide)
- 102825:** Contact point, ø2mm ball (carbide)
- 102826:** Contact point, ø3mm ball (carbide)

### FEATURES

- Universal application to all directions. (Not only the direction of the measuring point, but also the direction of measurement itself can be adjusted 360 degrees without moving the indicator.)

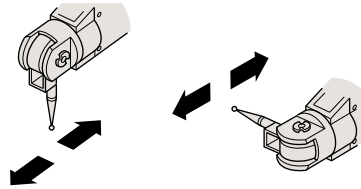

513-304GE

### SPECIFICATIONS

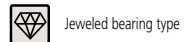

Metric		Range	Accuracy	Dial reading	Measuring force	Jeweled bearing type	—	—	—	—
Graduation	Order No.									
0.01mm	Basic set: 513-304GE, Full set: 513-304GT	0.8mm	8µm	0-40-0	0.3N or less	✓	—	—	—	—

Inch		Range	Accuracy	Dial reading	Measuring force	Jeweled bearing type	—	—	—	—
Graduation	Order No.									
.0005"	Basic set: 513-302G, Full set: 513-302GT	.03"	.0005"	0-15-0	0.3N or less	✓	—	—	—	—

### DIMENSION

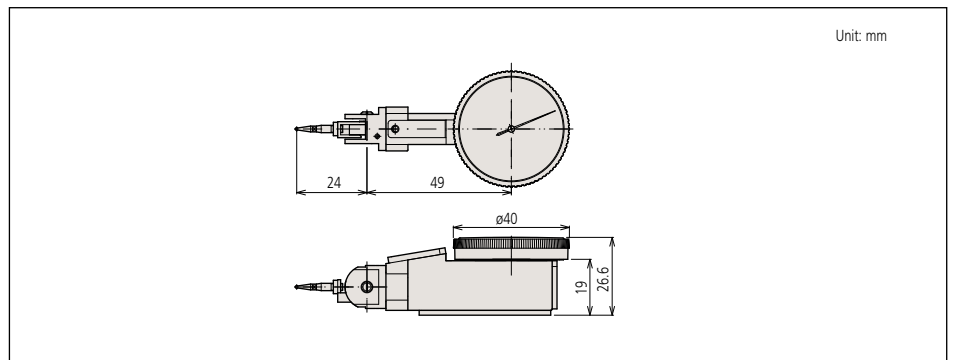

# Dial Test Indicator

## SERIES 513 — Horizontal Type

### FEATURES

- Performs easy and accurate measurement of narrow or recessed areas, plus inside and outside diameters that dial indicators cannot access.
- No-clutch structure for automatic reversal of measuring direction.
- Resistant to water and dust thanks to the one-piece bezel and "crystal" design with O-ring.
- The glare-free flat crystal face has a scratch-resistant coating.
- High-sensitivity and quick-response because of jeweled bearings.



513-474E



513-477E



513-471E

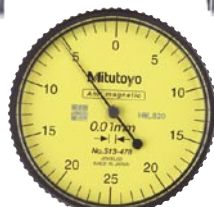

513-478E



513-475E

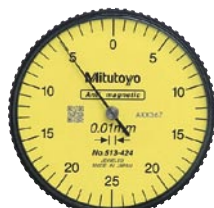

513-424E

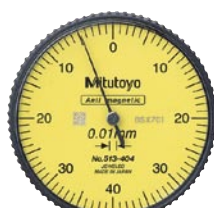

513-404E



513-414E



513-415E

**Ruby contact point models**

- Higher resistance to wear
- Non-magnetic, non-conductive tip allows use in EDM processes

**Carbide contact point models**



513-426E

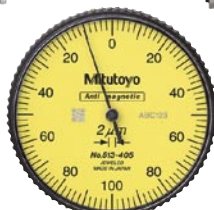

513-405E



513-425E



513-401E

### DIMENSION

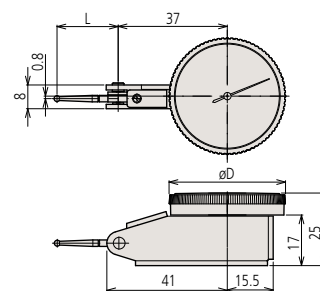

Order No.	L	D
513-424E	22.3	ø40
513-404E	20.9	ø40
513-415E	44.5	ø40
513-426E	22.3	ø40
513-405E	14.7	ø40
513-425E	14.7	ø40
513-401E	12.8	ø40
513-466E	22.3	ø28
513-464E	20.9	ø28
513-465E	14.7	ø28
513-414E	36.8	ø40
513-409	14.7	ø40

### Special Set: No. 513-908 (mm)

513-404E: Dial test indicator  
7014: Mini magnetic stand

### No. 513-907 (inch)

513-402: Dial test indicator  
7014: Mini magnetic stand



## Set Configuration: Metric and Metric/Inch

### Full set

Swivel clamp (900321, for  $\varnothing 4\text{mm}$ ,  $\varnothing 8\text{mm}$ , dovetail) Metric holding bar (L: 100mm)

### Plus set

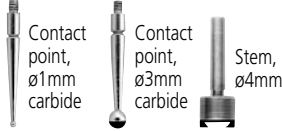

### Basic set

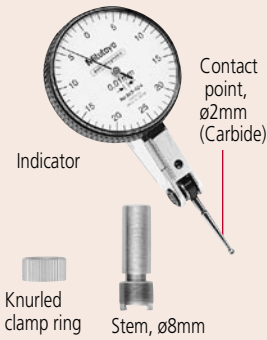

## Set Configuration: Inch and Inch/Metric

### Full set

Contact point, .039" DIA. carbide; Contact point, .118" DIA. carbide; Stem, .157" DIA.; Swivel clamp (900322, for .157" DIA., 3/8" DIA., dovetail) Inch holding bar (L: 4")

### Basic set

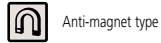
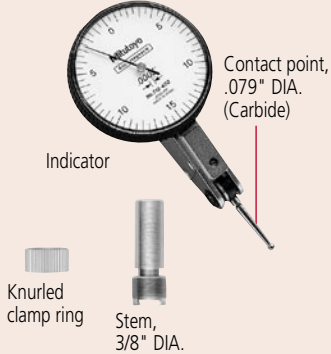

Anti-magnet type

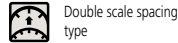

Double scale spacing type

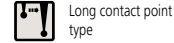

Long contact point type



Jeweled bearing type



Compact type

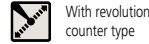

With revolution counter type



513-466E



513-464E



513-465E

## SPECIFICATIONS

### Metric

Graduation	Order No.			Range	Accuracy	Dial reading	Measuring force						
	Basic set	Plus set	Full set										
0.01mm	513-424E	513-424A	513-424T	0.5mm	5 $\mu\text{m}$	0-25-0	0.3N or less	✓	✓	—	✓	—	—
0.01mm	513-478E	—	—	0.5mm	5 $\mu\text{m}$	0-25-0	0.3N or less	✓	✓	—	✓	—	—
0.01mm	513-414E	513-414A	513-414T	0.5mm	10 $\mu\text{m}$	0-25-0	0.2N or less	✓	✓	✓	✓	—	—
0.01mm	513-466E	—	—	0.5mm	5 $\mu\text{m}$	0-25-0	0.3N or less	✓	✓	—	✓	✓	—
0.01mm	513-404E	513-404A	513-404T	0.8mm	8 $\mu\text{m}$	0-40-0	0.3N or less	✓	—	—	✓	—	—
0.01mm	513-474E	—	—	0.8mm	8 $\mu\text{m}$	0-40-0	0.3N or less	✓	—	—	✓	—	—
0.01mm	513-464E	—	—	0.8mm	8 $\mu\text{m}$	0-40-0	0.3N or less	✓	—	—	✓	✓	—
0.01mm	513-415E	513-415A	513-415T	1mm	10 $\mu\text{m}$	0-50-0	0.2N or less	✓	—	✓	✓	—	—
0.01mm	513-477E	—	—	1mm	10 $\mu\text{m}$	0-50-0	0.2N or less	✓	—	✓	✓	—	—
0.01mm	513-426E	513-426A	—	1.5mm	8 $\mu\text{m}$	0-25-0	0.4N or less	✓	✓	—	✓	—	✓
0.002mm	513-405E	513-405A	513-405T	0.2mm	3 $\mu\text{m}$	0-100-0	0.3N or less	✓	—	—	✓	—	—
0.002mm	513-475E	—	—	0.2mm	3 $\mu\text{m}$	0-100-0	0.3N or less	✓	—	—	✓	—	—
0.002mm	513-465E	—	—	0.2mm	3 $\mu\text{m}$	0-100-0	0.3N or less	✓	—	—	✓	✓	—
0.002mm	513-425E	513-425A	—	0.6mm	6 $\mu\text{m}$	0-100-0	0.4N or less	✓	—	—	✓	—	✓
0.001mm	513-401E	—	—	0.14mm	3 $\mu\text{m}$	0-70-0	0.3N or less	✓	—	—	✓	—	—
0.001mm	513-471E	—	—	0.14mm	3 $\mu\text{m}$	0-70-0	0.3N or less	✓	—	—	✓	—	—

\*provided with a  $\varnothing 2\text{mm}$  ruby contact point as a substitute for  $\varnothing 2\text{mm}$  carbide contact point.

### Inch

Graduation	Order No.			Range	Accuracy	Dial reading	Measuring force					
	Basic set	Plus set	Full set									
.0005"	513-402	—	513-402T	.03"	.0005"	0-15-0	0.3N or less	✓	—	✓	—	—
.0005"	513-472	—	—	.03"	.0005"	0-15-0	0.3N or less	✓	—	✓	—	—
.0005"	513-412	—	513-412T	.03"	.0005"	0-15-0	0.2N or less	✓	✓	✓	—	—
.0005"	513-479	—	—	.03"	.0005"	0-15-0	0.2N or less	✓	✓	✓	—	—
.0005"	513-462	—	—	.03"	.0005"	0-15-0	0.3N or less	✓	—	✓	✓	—
.0001"	513-403	—	513-403T	.008"	.0001"	0-4-0	0.3N or less	✓	—	✓	—	—
.0001"	513-473	—	—	.008"	.0001"	0-4-0	0.3N or less	✓	—	✓	—	—
.0001"	513-463	—	—	.008"	.0001"	0-4-0	0.3N or less	✓	—	✓	✓	—

\*provided with a  $\varnothing 2\text{mm}$  ruby contact point as a substitute for  $\varnothing 0.079"$  carbide contact point.

### Metric/inch

Graduation	Order No.			Range	Accuracy	Dial reading	Measuring force		
	Basic set	Plus set	Full set						
0.002mm, .0001"	513-409	—	513-409T	0.2mm, .0075"	3 $\mu\text{m}$	0-10-0, 0-38-0	0.3N or less	✓	✓

### Inch/Metric

Graduation	Order No.			Range	Accuracy	Dial reading	Measuring force		
	Basic set	Plus set	Full set						
.0005", 0.01mm	513-406	—	513-406T	.03", 0.7mm	.0005"	0-15-0, 0-35-0	0.3N or less	✓	✓

# Dial Test Indicator

**SERIES 513 — Horizontal (20 Tilted Face), Vertical, and Parallel Types**

## FEATURES

- Specially designed for easy viewing of measurements.

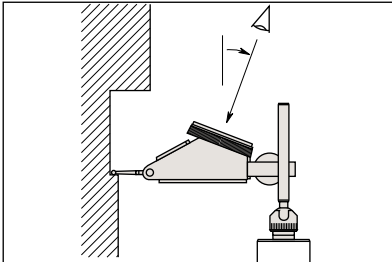

- The dial face obliquely faces upward, allowing users to read the graduations from the user's side. It is convenient when measuring on the side of a large workpiece and the workbench is high.

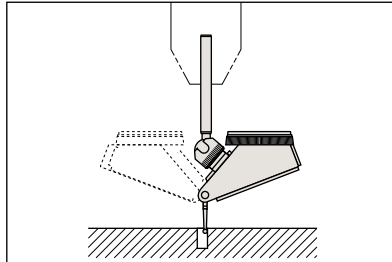

- Using the universal holder allows easy hole centering. The dial face always faces upward when the indicator is rotated, which makes reading easy.



513-454E



513-455E



513-444E



513-445E



513-284G



(Refer to the page 9 for details.)

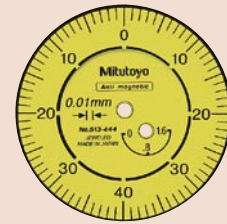

513-444E

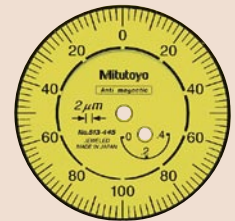

513-445E



513-454E  
513-284GE

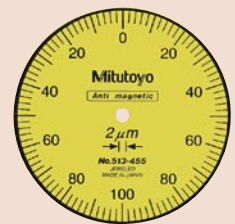

513-455E

## Optional Accessory

- : Swivel clamp (See page 278.)
- : Holding bar (See page 278.)
- : Stem (See page 278.)
- : Contact points (See page 278.)



Anti-magnet type



With revolution counter type



Jeweled bearing type



Long contact point type

### Set Configuration: Metric

#### Full set

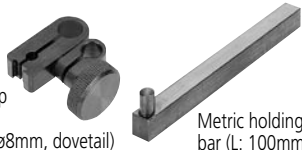
Swivel clamp  
(900321,  
for  $\phi 4\text{mm}$ ,  $\phi 8\text{mm}$ , dovetail)

Metric holding bar (L: 100mm)

#### Plus set

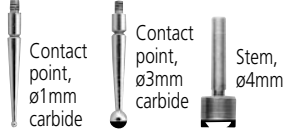
Contact point,  
 $\phi 1\text{mm}$  carbideContact point,  
 $\phi 3\text{mm}$  carbideStem,  
 $\phi 4\text{mm}$ 

#### Basic set

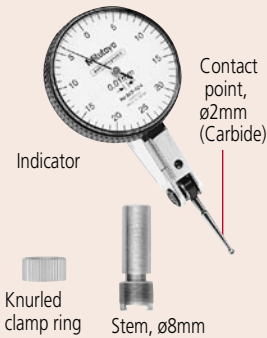

Indicator

Contact point,  
 $\phi 2\text{mm}$  (Carbide)

Knurled clamp ring

Stem,  $\phi 8\text{mm}$ 

### Set Configuration: Inch

#### Full set

Contact point,  
.039" DIA. carbideContact point,  
.118" DIA. carbideStem,  
.157" DIA.Swivel clamp  
(900322, for  
.157" DIA., 3/8" DIA.,  
dovetail)Inch holding bar  
(L: 4")

#### Basic set

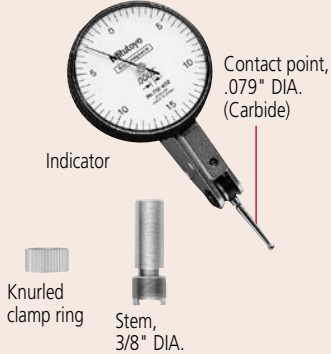

Indicator

Contact point,  
.079" DIA. (Carbide)

Knurled clamp ring

Stem,  
3/8" DIA.

### SPECIFICATIONS

#### Metric Horizontal (20° tilted face) type

Graduation	Order No.			Range	Accuracy	Dial reading	Measuring force					—	—	—
	Basic set	Plus set	Full set											
0.01mm	513-444E	513-444A	513-444T	1.6mm	10 $\mu\text{m}$	0-40-0	0.3N or less	✓	✓	✓	—	—	—	
0.002mm	513-445E	513-445A	513-445T	0.4mm	5 $\mu\text{m}$	0-100-0	0.3N or less	✓	✓	✓	—	—	—	

#### Inch Horizontal (20° tilted face) type

Graduation	Order No.			Range	Accuracy	Dial reading	Measuring force					Remarks
	Basic set	Plus set	Full set									
.0005"	513-442	—	513-442T	.06"	.0005"	0-15-0	0.3N or less	✓	✓	✓	—	—
.0005"	513-442-01	—	513-442T-01	.06"	.0005"	0-15-0	0.3N or less	✓	✓	✓	—	Blue dial
.0005"	513-442-06	—	513-442T-06	.06"	.0005"	0-15-0	0.3N or less	✓	✓	✓	—	Black dial
.0005"	513-446	—	513-446T	.06"	.0005"	0-15-0	0.2N or less	✓	✓	✓	✓	—
.0005"	513-446-06	—	513-446T-06	.06"	.0005"	0-15-0	0.2N or less	✓	✓	✓	✓	Black dial
.0001"	513-443	—	513-443T	.016"	.0002"	0-4-0	0.3N or less	✓	✓	✓	—	—
.0001"	513-443-06	—	513-443T-06	.016"	.0002"	0-4-0	0.3N or less	✓	✓	✓	—	Black dial

#### Metric Vertical type

Graduation	Order No.			Range	Accuracy	Dial reading	Measuring force			—	—	—	—
	Basic set	Plus set	Full set										
0.01mm	513-454E	513-454A	513-454T	0.8mm	8 $\mu\text{m}$	0-40-0	0.3N or less	✓	✓	—	—	—	—
0.002mm	513-455E	513-455A	513-455T	0.2mm	3 $\mu\text{m}$	0-100-0	0.3N or less	✓	✓	—	—	—	—

#### Inch Vertical type

Graduation	Order No.			Range	Accuracy	Dial reading	Measuring force			—	—	—	—
	Basic set	Plus set	Full set										
.0005"	513-452	—	513-452T	.03"	.0005"	0-15-0	0.3N or less	✓	✓	—	—	—	—
.0001"	513-453	—	513-453T	.008"	.0001"	0-4-0	0.3N or less	✓	✓	—	—	—	—

#### Metric Parallel type

Graduation	Order No.			Range	Accuracy	Dial reading	Measuring force			—	—	—	—
	Basic set	Plus set	Full set										
0.01mm	513-284GE	513-284GA	513-284GT	0.8mm	8 $\mu\text{m}$	0-40-0	0.3N or less	✓	—	—	—	—	—

#### Inch Parallel type

Graduation	Order No.			Range	Accuracy	Dial reading	Measuring force			—	—	—	—
	Basic set	Plus set	Full set										
.0005"	513-282G	—	513-282GT	.03"	.0005"	0-15-0	0.3N or less	✓	—	—	—	—	—

### DIMENSION

#### Horizontal (20° Tilted Face) Type

unit: mm

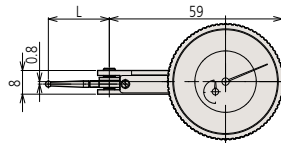

Order No.	L
513-444E	20.9
513-445E	14.7

Order No.	L
513-454E	20.9
513-455E	14.7

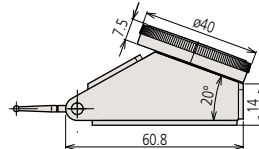

#### Parallel Type

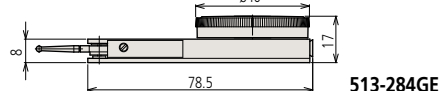
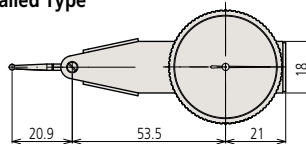

#### Vertical Type

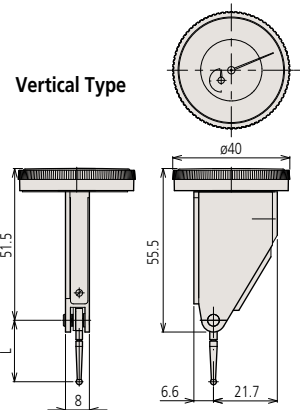

# Pocket Type Dial Test Indicator

## SERIES 513

### FEATURES

- Jeweled bearings assure higher sensitivity and accuracy.
- Reversible measuring direction.
- Two holding bars are supplied. (Full sets only.)
- Fully adjustable bezel/dial face.
- Contact point is adjustable within 220°.
- Bezel is sealed with an O-ring to keep out water / oil.

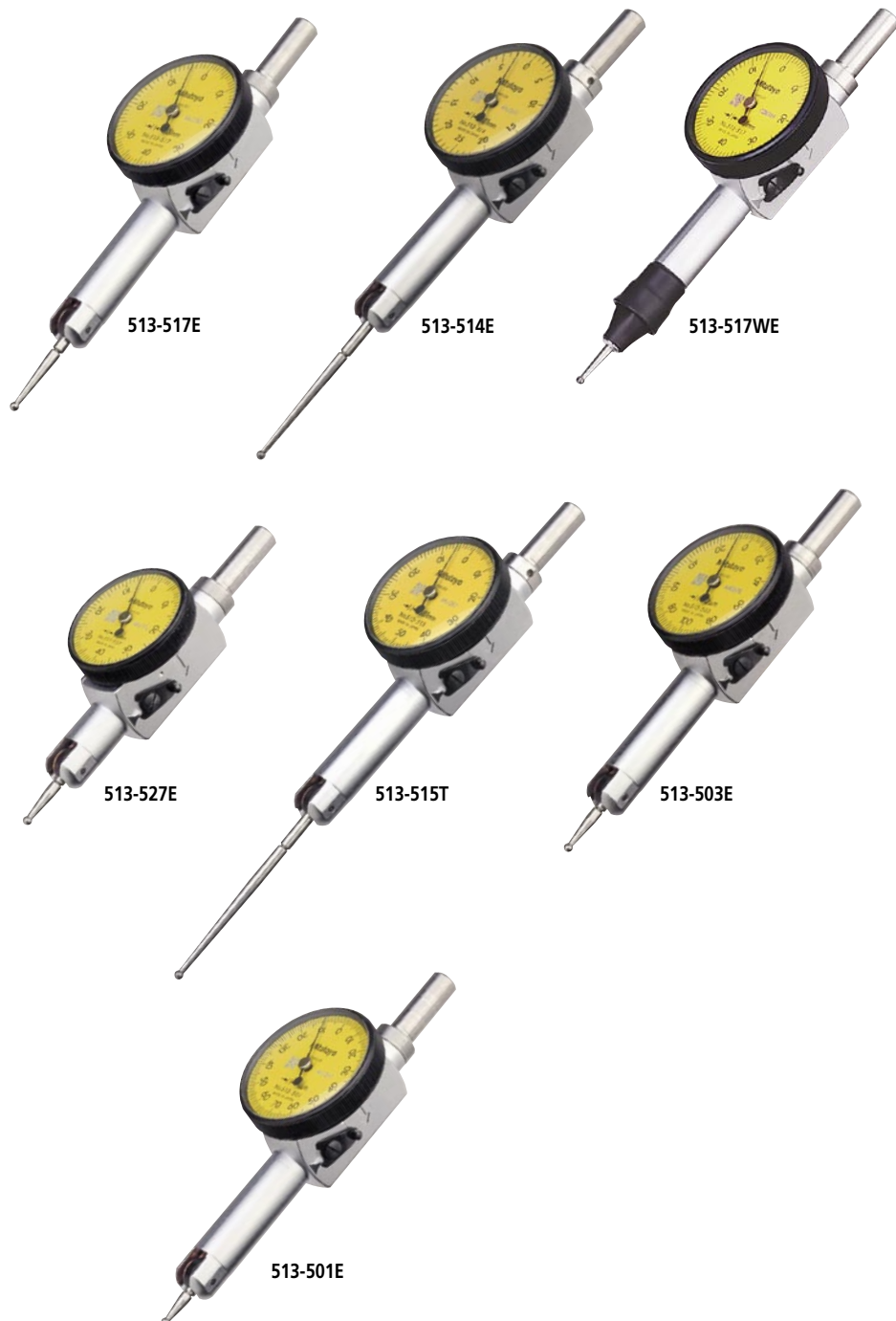

513-514E



513-517E  
513-517WE  
513-527E



513-515T



513-503E

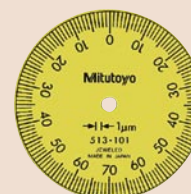

513-501E

### Optional Accessory

- : Swivel clamp (See page 279.)
- : Holding bar (See page 279.)
- : Stem (See page 279.)
- : Contact points (See page 279.)

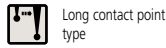

### Set Configuration: Metric

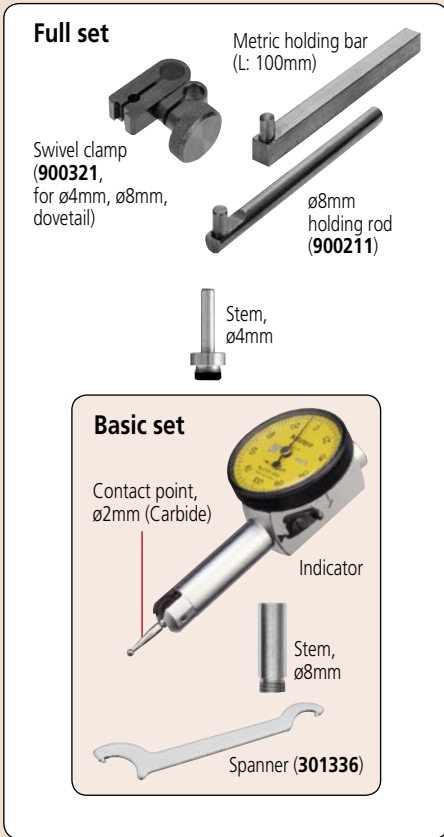

### Set Configuration: Inch

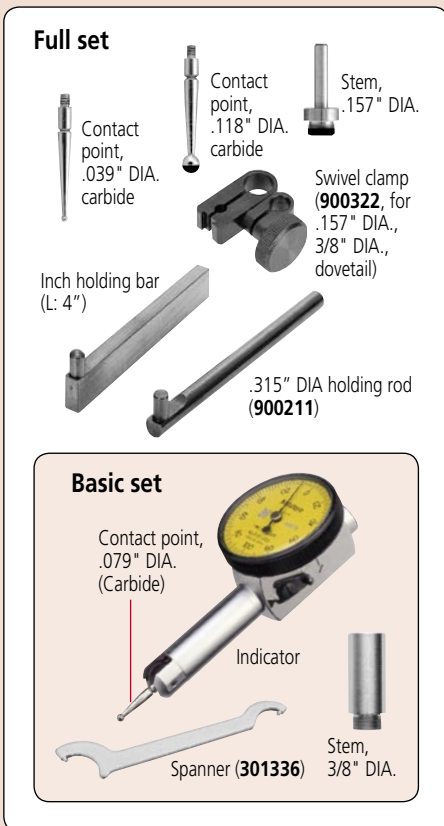

### SPECIFICATIONS

#### Metric

Graduation	Order No.		Range	Accuracy	Dial reading	Measuring force					—	—
	Basic set	Full set										
0.01mm	513-514E	513-514T	0.5mm	10 $\mu\text{m}$	0-25-0	0.3N or less	✓	✓	—	—	—	—
0.01mm	513-517E	513-517T	0.8mm	8 $\mu\text{m}$	0-40-0	0.3N or less	—	✓	—	—	—	—
0.01mm	513-517WE	513-517WT	0.8mm	8 $\mu\text{m}$	0-40-0	0.3N or less	—	✓	✓	—	—	—
0.01mm	513-527E	513-527T	0.8mm	8 $\mu\text{m}$	0-40-0	0.3N or less	—	✓	—	✓	—	—
0.01mm	—	513-515T	1mm	10 $\mu\text{m}$	0-50-0	0.3N or less	✓	✓	—	—	—	—
0.002mm	513-503E	513-503T	0.2mm	3 $\mu\text{m}$	0-100-0	0.3N or less	—	✓	—	—	—	—
0.001mm	513-501E	513-501T	0.14mm	3 $\mu\text{m}$	0-70-0	0.4N or less	—	✓	—	—	—	—

#### Inch

Graduation	Order No.		Range	Accuracy	Dial reading	Measuring force					—	—
	Basic set	Full set										
.001"	513-518	513-518T	.04"	.001"	0-20-0	0.3N or less	—	✓	—	—	—	—
.001"	513-528	513-528T	.04"	.001"	0-20-0	0.3N or less	—	✓	✓	—	—	—
.0005"	513-512	513-512T	.02"	.0005"	0-10-0	0.3N or less	✓	✓	—	—	—	—
.0001"	513-504	513-504T	.01"	.0002"	0-5-0	0.3N or less	—	✓	—	—	—	—

### DIMENSION

